



Mobile Communications



**VEHICULAR
CHARGER UNIT**
19B801507P1, P4



Ericsson GE Mobile Communications Inc.
Mountain View Road • Lynchburg, Virginia 24502

TABLE OF CONTENTS

	<u>Page</u>
SPECIFICATIONS	1
DESCRIPTION	2
OPERATION	2
CHARGE ONLY	2
CHARGE AND MONITOR	2
MOBILE CONFIGURATION	3
SPECIAL OPERATING PROCEDURES FOR THE TPX™ 8403/8603 RADIOS	3
CIRCUIT ANALYSIS	3
CHARGER BOARD	3
DISPLAY FULL BOARD	5
EXTERNAL ANTENNA	5
INSTALLATION	5
MAINTENANCE	5
DISASSEMBLY PROCEDURES	5
ADJUSTMENT PROCEDURES	5
TROUBLESHOOTING PROCEDURES	5
TEST ADAPTER	6

LIST OF TABLES

TABLE 1 - QUICK CHECKS	6
TABLE 2 - EQUIPMENT STATUS	6
TABLE 3 - VOLTAGE READINGS	6

SPECIFICATIONS*

INPUT POWER	11.1 TO 16.5 Volts DC, negative ground	
CURRENT DRAIN	2.6 A maximum	
INPUT CURRENTS		
Standby	1 mA maximum	
Radio Squelched, Trickle Charge	300 mA maximum	
Rated Audio, Rapid Charge	2600 mA maximum	
CHARGE TIME		
Standard High Capacity Batteries	3 Hours	
Extra High Capacity	4 Hours	
CHARGE CAPACITY AND TIME VS TEMPERATURE (Standard, High Capacity)		
	<u>Temperature</u>	<u>Time</u>
	+5°C (+41° F)	3.3 Hours
	+25°C (+77° F)	3.0 Hours
	+45°C (+113° F)	2.7 Hours
		<u>Capacity</u>
		100%
		100%
		70%
INDICATORS		
Radio Engaged	Red	
Charge	Red	
Ready	Green	
Xmit	Red	
RATED AUDIO POWER	12 Watts (<% distortion)	
SQUELCHED FM HUM and NOISE	65 dB	
ALTERNATOR NOISE REJECTION		
Receive	60 dB below rated audio	
Transmit	60 dB below 4.5 kHz Deviation	
MICROPHONE IMPEDANCE	600 Ohms	
SPEAKER IMPEDANCE	4 Ohms	
DIMENSIONS (H x W x D)	22.6 x 15 x 7 cm (8.9 x 5.9 x 2.7 ins.)	
WEIGHT	1.4 kG (3.1 lb)	

* These specifications are intended primarily for the use of the service technician.

DESCRIPTION

The Ericsson GE Vehicular Charger Units convert an M-PA, M-PD or TPX Personal Series radio into a mobile configuration when the radio unit is latched into the charger. It may be used to charge a battery pack only, as a Monitor Receiver and battery charger, or as a two way vehicular radio and battery charger. The Vehicular Charger connects the radio to an external antenna and provides a full 12 watts audio output to an external speaker. It will recharge the Standard, High or Extra High capacity batteries.

The external antenna, microphone, PTT circuit, speaker, and charging contacts are automatically connected when the radio is latched into the charger. Radio Detect switch S1, located in the battery compartment, applies power to the charging circuit when the radio is inserted. A second switch senses the size of the battery pack and adjusts the charging rate accordingly.

Heat sensors constantly monitor the temperature of both the battery pack and the charging insert. When a cold battery pack is inserted into the charging insert, the charger will wait until the battery pack has warmed up to within about 10°C of ambient. The charger will then, automatically, apply the high charge rate. When the battery pack overcharges enough to heat the cells 10°C above ambient, the charger will switch from fast charge to trickle charge.

The charger also has a memory that is set when the charger switches from the high charging rate to the trickle charge rate, and is reset when the battery pack is removed from the charging insert. If a hot battery is in the charging insert and the memory has not been reset, the charger will remain at the trickle charge rate. If the memory has been reset the charger will wait until the battery pack has cooled before automatically switching to fast charge. If a fully charged battery pack is removed from the charging insert and then reinserted, it will charge for about 1/2 hour until the cell reheats.

A voltage cut off circuit also has been incorporated to prevent overcharging and "gassing" of the battery pack. Battery voltage is constantly monitored and, if the battery pack charge terminal voltage exceeds 9.5 volts, high rate is terminated and the LED READY light is turned on.

If the VOLUME switch (attached to the rotary volume control) is in the OFF position, only the charging function operates regardless of the latch position.

If the radio is not latched, and the ON/OFF switch on the radio is on, audio will be heard from the radio speaker. Note: The radio must have been turned on before being inserted into the charger. The external microphone, speaker,

and outside antenna are not connected until the latch is engaged.

If the VOLUME switch is on, when the radio is latched, the speaker, microphone and antenna in the personal radio are disconnected and connections are automatically made to the charger and its external microphone, speaker, and antenna. In addition, latching the radio causes the power switch to be turned on, supplying voltage to the audio amplifier and dead battery power supply. It also turns the RADIO ENGAGED LED on. The personal radio is powered on regardless of the position of its power switch.

If the radio is turned off (switch on battery), latching the radio into the charger turns on a regulated 8.0 volt power supply which powers the portable radio while the battery is being charged. Dead battery operation is provided during transmit by connecting the 8.0 volt power supply across the battery during PTT operation.

OPERATION

Temperature characteristics of nickel cadmium batteries, prevent a full charge at temperature extremes. For a maximum charge, recharge the battery pack at ambient room temperature or between 65 and 85 degrees F.

CAUTION

The Vehicular Charger is designed to recharge the Standard, High, and Extra High capacity battery pack. Attempting to recharge any other battery pack or batteries may result in damage to equipment, leakage, or explosion.

Four indicators provide status information for the charger/radio combination. A red LED indicator, RADIO ENGAGED, turns on when the radio is inserted properly into the charger and a second red indicator labeled CHARGING will light, indicating the battery is being charged. When the battery pack is fully charged a green LED indicator labeled READY will light and the charger will automatically switch from a rapid charge rate to a trickle charge rate. A red XMIT indicator lights when the external PTT switch is pressed, indicating the transmitter is keyed. (The radio must be properly engaged). Refer to Figure 1 for location of controls and indicators.

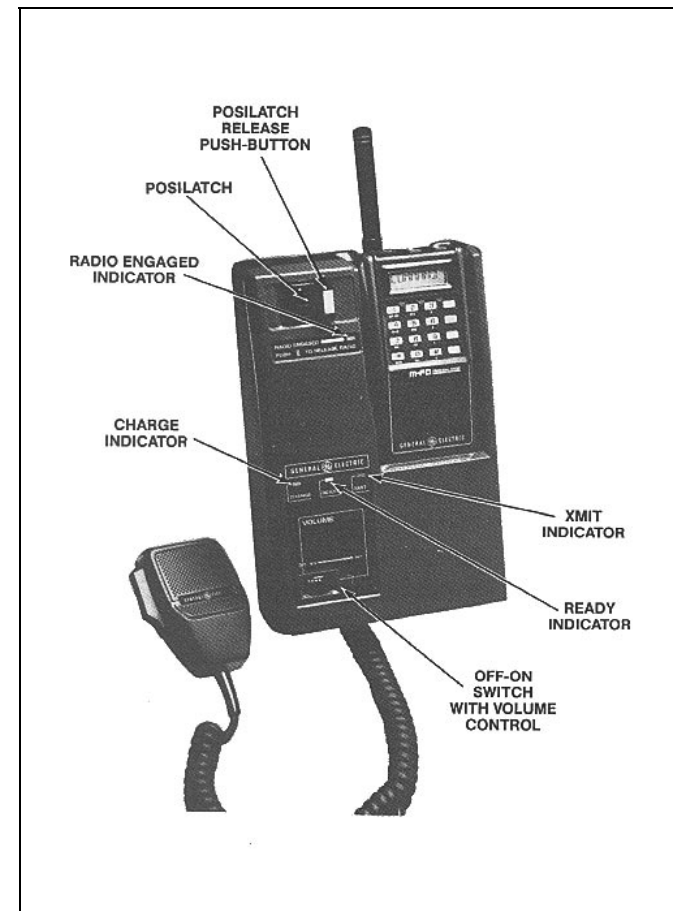

Figure 1 - Vehicular Charger

Three operational modes are possible:

- Charge battery pack only
- Monitor receive frequency (s) only and charge battery pack.
- Full radio operation and charge battery pack.

CHARGE ONLY

The following procedures will permit recharging of the portable radio unit battery pack only. No activation of the vehicular charger POSILATCH™ or the VOLUME switch is required.

1. Set power switch on portable radio unit battery pack to OFF position.
2. Insert portable radio unit into charging compartment with its speaker facing outward (see Figure 2.).

3. The red CHARGE indicator will light and remain lit until the portable radio unit is removed or until the vehicular charger unit circuits sense that the battery pack has reached total charge capacity, at which time the green READY indicator will also light, indicating that the charger has switched to trickle charge rate.
4. Remove the portable radio unit from the charger compartment as shown in Figure 2.

CAUTION

DO NOT use the antenna to remove the portable radio from the charging compartment.

CHARGE AND MONITOR

The following procedures will permit recharging of the portable radio unit battery pack and also permit the radio to act as a monitor receiver. No activation of the vehicular charger POSILATCH or the VOLUME switch is required.

NOTE

The portable radio is not connected to the external antenna in this mode.

1. Set power switch on the portable radio unit battery pack to ON position.
2. Insert portable radio unit into charging compartment with its speaker facing outward (see Figure 2.).
3. The red CHARGE indicator will light and remain lit until the portable radio unit is removed or until the vehicular charger unit circuits sense that the battery pack has reached its total charge capacity, at which time the green READY indicator will also light, indicating that the charger has switched to trickle charge rate.
4. Remove the portable radio unit from the charger compartment as shown in Figure 2.

CAUTION

DO NOT use the antenna to remove the portable radio from the charging compartment.

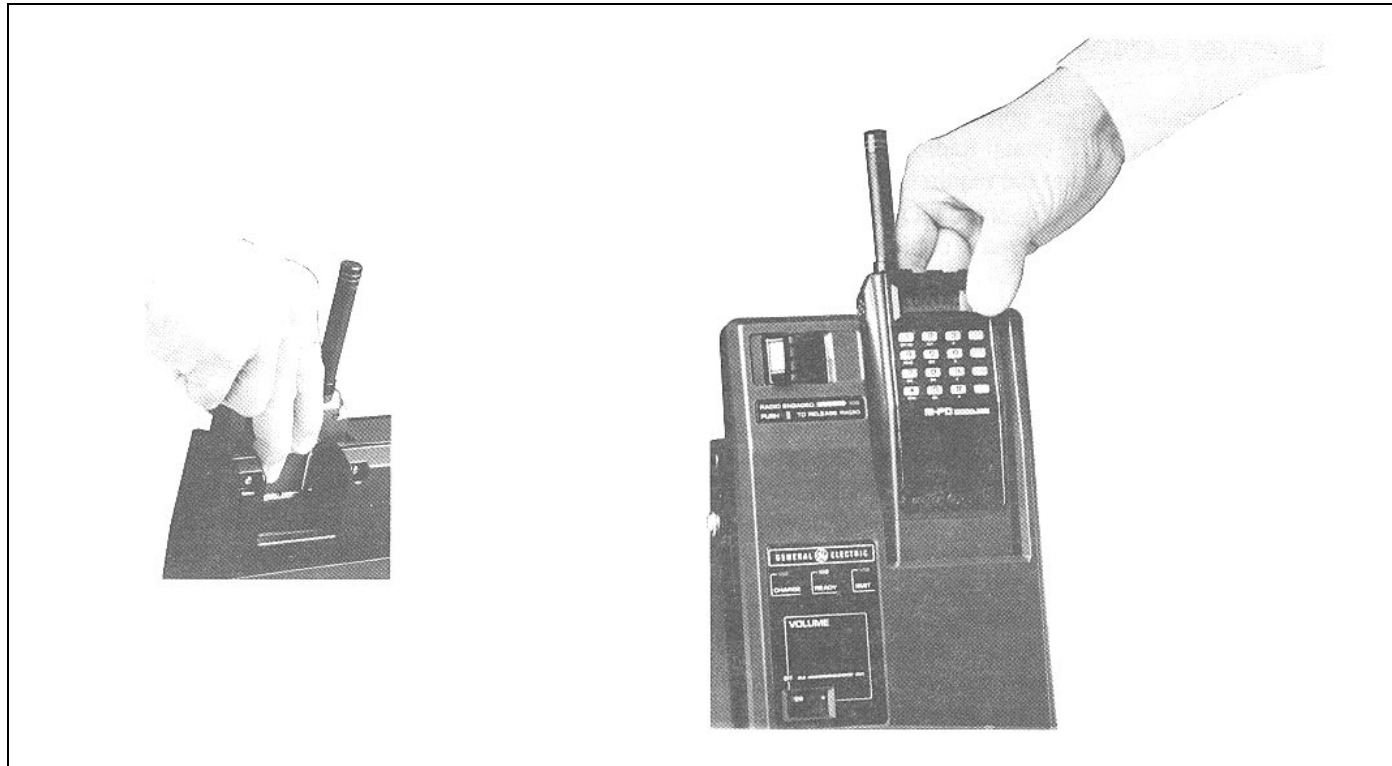

Figure 2 - Inserting And Removing Portable Radio Unit

MOBILE CONFIGURATION

The following procedures permit the recharging of the portable radio unit battery pack and the functional conversion of the portable radio unit into a mobile configuration.

1. The power switch on the portable radio unit battery pack may be in either the ON or OFF position.
2. Insert portable radio unit into charging compartment with its speaker facing outward (see Figure 2.).
3. Slide the POSILATCH toward the portable radio unit until you feel it engage and the red RADIO ENGAGED indicator lights.
4. Turn the VOLUME switch on the vehicular charger unit to the ON position. Then adjust the VOLUME control for a comfortable listening level from the external speaker.
5. The red CHARGE indicator will light and remain lit until the portable radio unit is removed or until the vehicular charger unit circuits sense that the battery pack has reached its total charge capacity, at which time the green READY indicator will also light, indi-

cating that the charger has switched to trickle charge rate.

6. The red XMIT indicator will light each time the PTT switch on the external microphone is activated.
7. To remove the portable radio unit from the charging compartment, press the push-button release on the POSILATCH and slide the latch away from the portable radio unit. The red RADIO ENGAGED indicator will turn off and the portable radio unit can be removed from the charging compartment (see Figure 2.).

CAUTION

DO NOT use the antenna to remove the portable radio from the charging compartment.

SPECIAL OPERATING PROCEDURES FOR THE TPX™ 8403/8603 RADIOS

The Vehicular Charger unit will accept either the M-PA, M-PD or TPX series Personal Radio Units. However, since the TPX series operates to the requirements of the GE-MARC V system, the following operational procedures must be observed when a TPX radio is used in conjunction with the Vehicular Charger Unit.

1. When initiating a call, the push-to-talk switch (PTT) must be keyed and then released to hear the channel acquisition tone. The audio from the vehicular charger external speaker is muted each time the PTT is keyed.
2. When the TPX 8603 (with DTMF option) radio is used in the vehicular charger, it is recommended that telephone interconnect or dispatch over dial calls be made using the number stored in the TPX's memory locations. Numbers may be directly dialed into the unit but they will not be accompanied with audible feedback tones.

CIRCUIT ANALYSIS

The Vehicular Charger is comprised of a Charger board, LED board, Display Full board, and a UDC board.

CHARGER BOARD

The Charger board contains the charging circuit with voltage and temperature cut-off circuits, an 8 volt regulator circuit, and a 12 watt audio amplifier.

Charging Circuit

When power is first applied to the charger, the voltage at pin 5 of Comparator A7 is higher than at pin 6 due to the charging time of C18. The higher voltage causes the output at pin 7 of A7 to go high, keeping A13 turned off. This allows the battery to start charging. A block diagram of the Vehicular Charger is shown in Figure 4.

Charging current flows through series connected resistors R21 and R22 to regulator transistor Q3. The output of Q3 is connected to the positive charging contact of the battery. Test Point TP2 provides a convenient place to monitor the positive battery contact. A portion of the charging current is routed through resistor R24 and transistor Q2 to turn on CHARGE LED DS3 on the LED board and to provide a trickle charge when Q2 turns off. The series connected

charge circuit determines the high charge rate and is controlled by the temperature cut off circuit.

Charger Control Circuit

The Charger Control circuit consists of a temperature cut off circuit and battery charged memory circuit. The temperature cut off circuit consists of integrated circuit A13, a bridge circuit comprised of R29, R30, R33, thermistors RT1 and RT (BATT), and associated circuitry. Temperature cut off IC A13 monitors the temperature of the charging insert through thermistor RT1 and the temperature of the battery pack through internal thermistor RT (BATT). It also controls transistors Q3 and Q4, turns the "READY" indicator on when the battery pack is fully charged, and provides memory to prevent the same battery pack from being recharged at the high rate.

Thermistors RT1 and RT (BATT) are connected with R29, R30, and R33 to form a bridge circuit (see Figure 3). The output of the bridge circuit is connected to terminals 13 and 14 of A13.

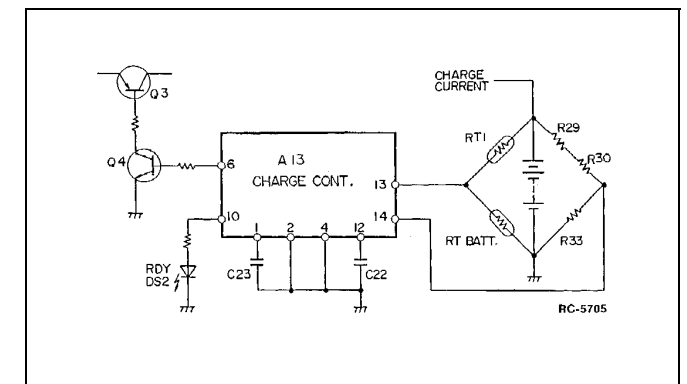

Figure 3 - Simplified Temperature Cut Off Circuit

When the battery pack temperature is more than 10°C (18°F.) below ambient, thermistor RT (BATT) exhibits a high resistance, causing the voltage on A13-13 to be larger than the voltage on A13-14. (The same thing would occur if there were no battery pack present). There is no output from A13-6 or A13-10. Transistor Q3 and LED READY indicator DS2 remain off. The battery pack charges at the trickle charge rate, determined by series resistance R24, until the temperature is less than 10°C below ambient. At less than 10°C below ambient, the voltage at A13-13 is still larger than the voltage on A13-14, the output at A13-6 goes high causing transistor Q4 to conduct, turning Q3 on and beginning the high rate charge.

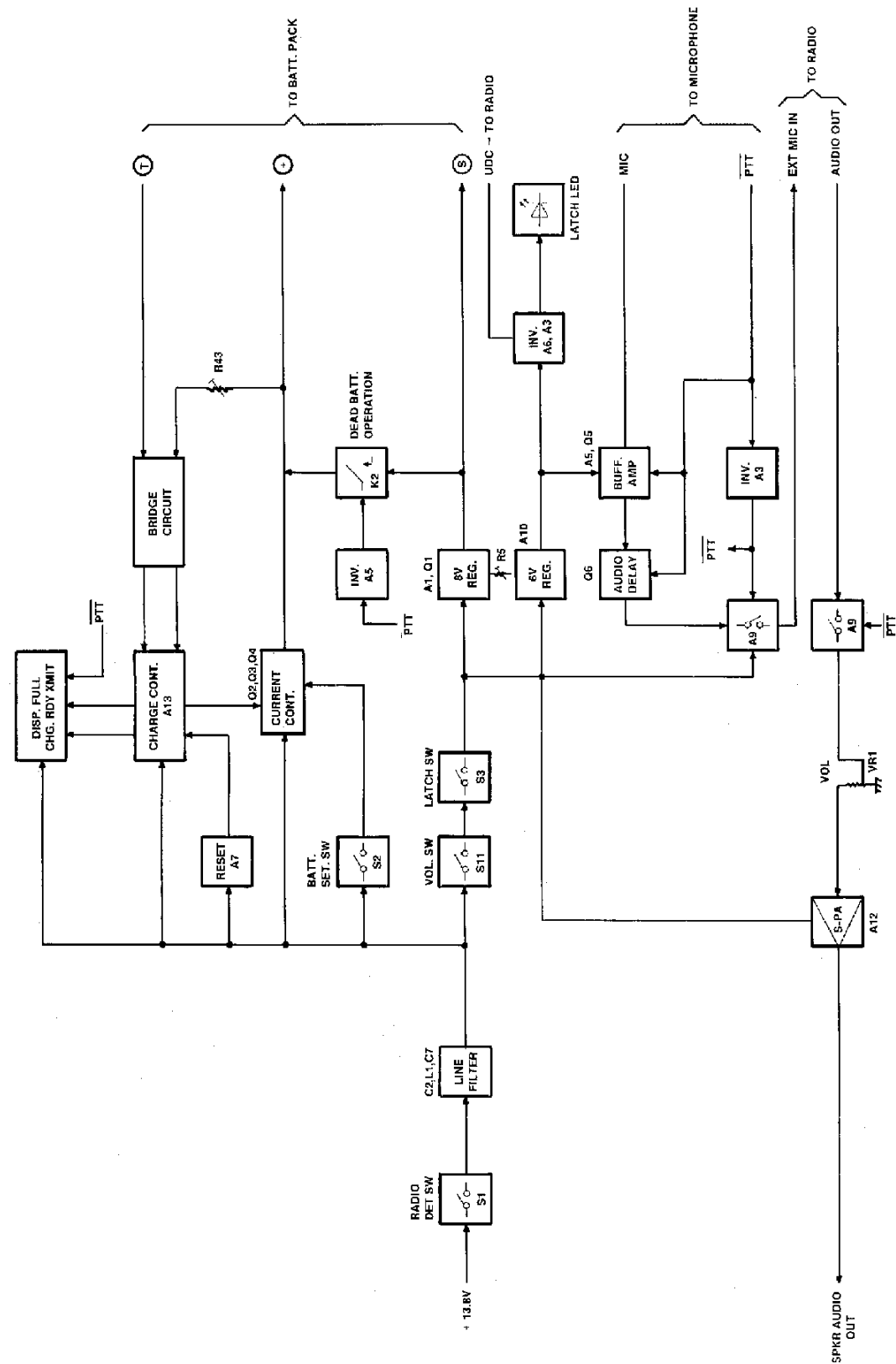

Figure 4 - Vehicular Charger W/12 Watt Amplifier

As the battery pack temperature increases to 10°C above ambient at end of charge, the voltages at A13-13 and A13-14 become equal, indicating the bridge circuit is balanced and the battery pack is fully charged. A14-6 goes low, causing Q4 to stop conducting. Q3 cuts off and the charge rate switches from the high charge rate to the trickle charge rate. The equal voltages on A13-13 and A13-14 cause the output at A13-10 to go high, turning READY indicator DS2 on.

A memory circuit internal to A13 is set so that the same battery can not be recharged at the high rate unless it first has been discharged or removed from the charger. When the battery pack is removed from the charging insert, RT (BATT) is removed from the bridge circuit causing the bridge to again be unbalanced. A13 senses the bridge in an unbalanced state, the voltage A13-13 being larger than the voltage on A13-14, and resets the charger memory. Microswitch S1 will also remove power from the charger circuits, causing the memory to reset.

Voltage Controlled Cut Off

The voltage controlled cut off circuit monitors the battery voltage and cuts off regulator Q3 when the battery charging terminal voltage exceeds 9.5 Vdc. It is comprised of Comparator A7, Charge Control IC A13, and associated circuitry.

A reference voltage derived from voltage divider R37, R38, R41, and zener diode CR12 is applied to pin 2 of Op-Amp A7. Resistor R43 is adjusted for a battery charging terminal voltage of 9.5 Vdc. A voltage equal to the reference voltage on pin 2 is applied to pin 3 of A7. This causes A7-1 to go high, applying a lesser voltage to A13-14 than is applied to A13-13. This causes A13 to turn Q3 off and turn READY indicator DS2 on.

NOTE

During charging there is one diode drop between the (+) charge terminal and the (+) terminal of the battery pack.

Power Input And 8 Volt Regulator

A positive 13.8 Vdc from the vehicle battery is supplied to the Charger board through a 5 ampere fuse and J1-6. Diode CR14 provides reverse voltage polarity protection. Voltage regulator A1 regulates the vehicle input battery voltage (13.8 Vdc) down to +8.0 Vdc and supplies it to the circuitry in the personal radio while the battery in the personal radio is being charged.

When a radio is inserted into the charger, radio detect microswitch S1 closes and applies 13.8 Vdc to charging control circuit A13 through a line filter consisting of C1, C2, C7, and

L1. 13.8 Vdc is also applied through J7-4, VOLUME control on-off switch S11, J7-5, J9-1, RADIO ENGAGED (latch) switch S3 to Comparator A5, audio amplifier A12 and to 8 volt regulator A1.

Input voltage to regulator A1 is applied to pins 11 and 12. The output of A1 controls the base of NPN pass transistor Q1, causing it to increase or decrease conduction as required by the load. Q1 functions as a variable resistor. The regulated output voltage is set to 8.0 Vdc by variable resistor R5. TP1 provides a convenient place to monitor the 8.0 Vdc output of regulator A1. The regulated 8.0 Vdc output is applied directly to the radio, or through contacts 3 and 4 of K2 and to the battery charging terminal. K2 is controlled by the microphone PTT switch through inverter A3 and is energized when the PTT switch is operated. K2 allows operation of the radio even though the battery may be dead.

Audio Amplifier A12 (12 Watts)

Audio amplifier A12 is an integrated circuit used to amplify receive audio from the radio to a level of 12 watts. The amplified audio is then applied to a 15-watt, 4-ohm speaker through J1-4 &5.

Receive audio (audio out) from the radio is applied to the input of audio amplifier, A12-10, through the UDC connector and cable assembly CA1 and J6-6 on the Charger board, contacts 8 & 9 on analog switch A9, and volume control/ on-off switch VR1/S11. The speaker is connected through P1 to J1. The audio input level from the radio is controlled by volume control/on-off switch VR1/S11.

A12 contains internal protection circuitry to safeguard against line surges, thermal overloads, and speaker shorts to ground. Input voltage (13.8 Vdc) from the battery is applied to A12-6.

External Microphone

The external microphone circuit consists of buffer/amplifier A5 and Q5, audio delay circuit Q6, analog switch A9, and PTT inverter/buffer A3.

Audio Delay

Prior to operating the PTT switch, audio delay transistor Q6 is turned on and Capacitor C65 charged through CR15 and R54 (13.8 Vdc). During this time Q6 and closed contacts A9-3 & 5 and 8 & 9 apply ground to the receive audio line from the radio and the external mic audio line to prevent any unwanted audio from entering the 12 - watt audio amplifier.

Pressing the PTT switch applies a ground to the anode of diode CR15, reverse biasing the diode and removing the charge path for C65. C65 discharges through R78 and the base emitter junction of Q6, holding it on for approximately 25 milliseconds to allow the transmitter to come up to full power. When the PTT switch is released diode CR15 is again forward biased and begins to charge C65. Q6 remains off for approximately 25 milliseconds until the charge on C65 exceeds the threshold point and allows Q6 to turn on. This action eliminates audio pops and clicks heard over the speaker when the PTT switch is operated.

MIC Audio

Operating the PTT switch applies a ground return to the mic pre-amp, energizing the microphone. It also applies ground to PTT inverters A3A- A3D which distribute PTT control throughout the charger and back to the radio through the UDC connector. Contacts 1 & 2 and 8 & 9 of analog switch A9 close and contacts 3 & 5 and 6 & 10 open.

Mic audio is passed through buffer/amplifier A5/Q5, A9, and audio delay circuit Q6. (The amount of delay is determined by an RC network consisting of R78 and C65). Mic audio is then coupled through C31, J6-2 (EXT MIC IN), and the UDC connector to the radio for transmission.

DISPLAY FULL BOARD

The Display board provides the current status information for the Vehicular Charger and radio. It contains the READY, CHARGE, and TX LED status indicators and associated circuitry. The cathodes of DS2 and DS3 are at ground and turn on when a positive voltage from the charge control circuit is applied.

READY indicator DS2 is controlled by A13 and turned on when the battery is fully charged as indicated by a positive voltage being applied from A13-10 through J7-7 to the anode of DS2, turning DS2 on.

CHARGE indicator DS3 is controlled by BATT SET 2 transistor Q2. When the battery is being charged Q2 is turned on, applying 13.8 Vdc from the battery input at J1-6 through J7-6 to the anode of DS3, turning DS3 on.

TX indicator DS1 is controlled by the PTT switch. When the microphone is keyed, PTT goes low, applying ground through J7-8 to the cathode of DS1, turning DS1 on. The anode is connected to the +13.8 Vdc input voltage bus through J7-2.

EXTERNAL ANTENNA

An external antenna may be connected to the radio through cable CA2 and the UDC connector. A TNC connector jack is located on the bottom of the Vehicular Charger. Refer to the Installation Manual for specific installation instructions.

INSTALLATION

Install the Vehicular Charger in a convenient place where it will not interfere with the safe operation of the vehicle. Refer to the Installation manual for specific installation instructions.

MAINTENANCE

The Maintenance section contains Disassembly instructions, Troubleshooting Procedures, and Adjustment Procedures. A Test Adaptor may be constructed to facilitate servicing the Vehicular Charger. The Test Adaptor is used to simulate actual battery pack conditions and to determine if the charger is working properly. Simulations include cold battery pack, battery pack at room temperature, and a hot battery pack. Pertinent information is provided in a separate section at the end of this manual.

DISASSEMBLY PROCEDURES

To Remove The Top Cover:

Remove the six Phillips head screws on the back of the housing. (three at the top edge, two at the bottom corners, and one in the center).

To Remove The Charge Board:

Remove the top cover.

Remove the four screws from the Charge board and four screws from the heatsinks for Q1, Q3, and A12.

To Remove The Repeater Display Board:

Remove the top cover.

Remove the four screws securing the Display board to the chassis.

ADJUSTMENT PROCEDURES

Test Equipment Required

1. Test Adaptor
2. Digital Voltmeter

Voltage Cutoff

1. Connect the Test Adaptor to TB-1.
2. Set switch S1 on Test Adaptor to position 2.]
3. Set S1 on Charge Board to "ON" to apply power to the charging circuit.
4. Set R43 on Charge Board fully counter-clockwise (CCW).
5. Connect the Digital Voltmeter to TP2, and set its voltage at +9.5 V + 0.05 V by adjusting trimmer R4 on the Test Adaptor.
6. Verify that voltage on A13-6 exceeds +10 volts.
7. Slowly adjust R43 clockwise until the RDY indicator just turns on.

+8 Volt Regulator

1. Connect the Digital Voltmeter to TP1, and set its voltage at +8.0 V + 0.05 V by adjusting R5.

TROUBLESHOOTING PROCEDURES

A Troubleshooting Procedure is provided to assist the service technician to rapidly isolate a fault in the equipment. A table of Quick Checks and reference tables containing typical voltage readings and pin status for various modes of operation are provided as a troubleshooting aid.

Test Equipment Required

Multimeter
Test Adaptor

Procedures

1. Connect the Test Adaptor to TB1 on the Charge Board.
2. Set S1 on the Test Adaptor to position 2.
3. Set S1 on the Charger Board to ON to power up the charging circuit.
4. Adjust R4 on the Test Adaptor for +8.5 Vdc as measured at TP2 on the Charge Board.
5. Set S1 on the Charge Board to OFF. Set S1 on the Test Adaptor to position 1.
6. Set S1 on the Charge board to ON. Refer to Tables 1 and 2 and monitor the reference points listed. Problem areas are identified by an indication other than that listed in the tables.
7. Set S1 on the Charger Board to the OFF position. Set S1 on the Test Adaptor to position 3.
8. Set S1 on the Charge Board to the ON position and then back to the OFF position.
9. Disconnect the Test adaptor from TB1.
10. Set S1 on the Charge Board to the ON position. This completes the operational checks of the charger.

Table 1 - Quick Checks

PROBLEM	ACTION
1. CHARGE Led does not light	Check input fuse, Q2, & C19
2. READY light fails to come on. Battery pack is good. Charging time has elapsed.	Check Q3, Q4, & DS4
3. A13-10 always high. Logic fails to reset.	Check C19
4. A13-6 always low. No fast charge.	Check C22
5. A13-5 always low. Logic will not reset	Check C23
6. Fast charge circuit does not open.	Check CR9, Q3, & Q4 for

Table 2 - Equipment Status

REF STEP	SW POS	A13 6	PIN 5	NO 10	CHGR LED	READY LED	REMARKS
6	1 2 3	LOW* HIGH* LOW	LOW LOW HIGH	LOW LOW HIGH	ON ON ON	OFF OFF ON	COLD BATTERY NORMAL BATTERY CHARGING CHARGED BATTERY
7	3	LOW	LOW	LOW	ON	OFF	HOT BATTERY
8	N/A	LOW	LOW	LOW	OFF	OFF	NO BATTERY

* LOW- Less than 1.0 Volt
HIGH- Greater than 3.0 Volts

Table 3 - Typical Voltage Readings (all voltages are + dc.)

Power Supply Voltage: +13.8 Vdc.				
CHECK POINT	S1 : ON W/O BATTERY	RAPID CHARGING STANDARD HI CAPACITY		TRICKLE CHARGING STANDARD/HI CAPACITY
TP2	8.35	8.50	8.57	8.37
TP5	-	4.15	4.20	4.8
TP6	4.74	4.74	4.74	4.74
TB1-4 (T)	5.60	5.47	5.54	3.53
Q3-E	13.79	12.02	11.98	13.79
Q4-C	13.37	0.03	0.03	13.36
A13-14	4.04	3.58	3.68	8.08
A13-12	5.13	11.09	11.05	5.21

TEST ADAPTOR

A Test Adaptor may be constructed to facilitate servicing the Vehicular Charger. The Test Adaptor is used to simulate actual battery pack conditions and to determine if the charger is working properly. Simulations include cold battery pack, battery pack at room temperature, and a hot battery pack. A Schematic Diagram and Parts List are shown below.

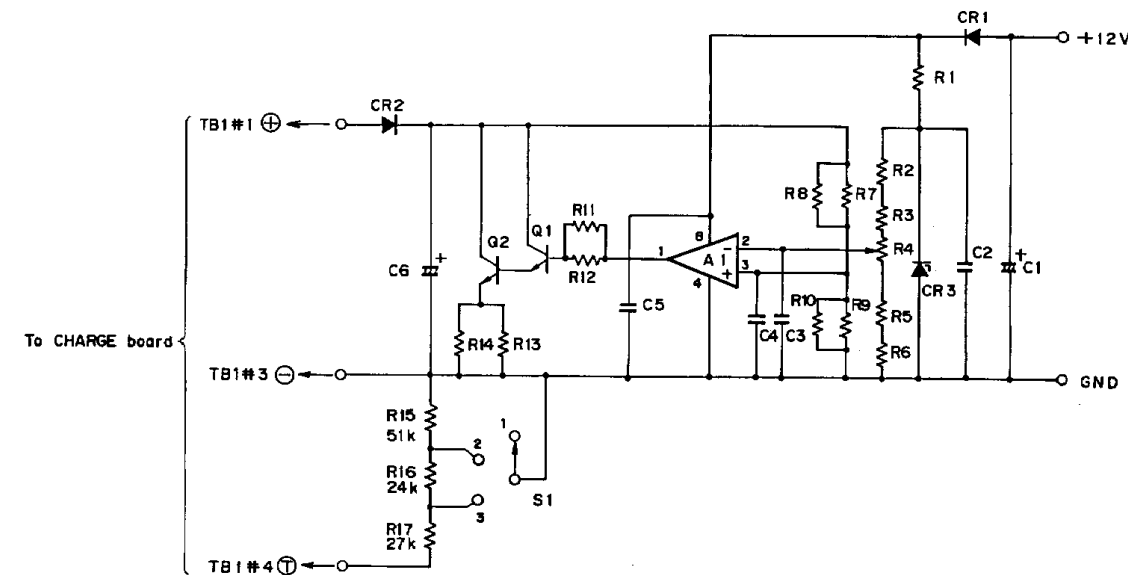

NOTE 1. R15, R16 and R17 are 1%.

PARTS LIST

LBI-31911
TEST ADAPTOR

SYMBOL	GE PART NO.	DESCRIPTION
----- INTEGRATED CIRCUITS -----		
A1	K19/2AAR005141	OP-AMP HA17904GS
----- CAPACITORS -----		
C1	K19/2CBR035045	Al. Electrolytic: 100 uF, 25V
C2 thru C5	K19/2CAJ031502	Ceramic: RPE122F104Z50, 0.01 uF
C6	K19/	Al. Electrolytic: 1000 uF, 35V
----- DIODES -----		
CR1 and CR2	K19/20BC008319	V06C
CR3	K19/20BB005845	RD6.8ER
----- TRANSISTORS -----		
Q1	K19/	2SC1815
Q2	K19/	2SD235
----- RESISTORS -----		
R1	K19/2RAA002028	Carbon fixed: RD25S, 680 ohms ±5%
R2	K19/2RAA002050	Carbon fixed: RD25S, 1 Kohm ±5%
R3	K19/2RAA002209	Carbon fixed: RD25S, 15 Kohm ±5%
R4	K19/2RFA045016	Variable: KI61108TE, 10 Kohm ±5%
R5 and R6	K19/2RAA002209	Carbon fixed: RD25S, 15 Kohm ±5%
R7	K19/2RAA002448	Carbon fixed: RD25S, 100 Kohm ±5%
R8	K19/2RAA002209	Carbon fixed: RD25S, 15 Kohm ±5%
R9	K19/2RAA002448	Carbon fixed: RD25S, 100 Kohm ±5%
R10	K19/2RAA002209	Carbon fixed: RD25S, 15 Kohm ±5%
R11	K19/2RAA002448	Carbon fixed: RD25S, 100 Kohm ±5%
R12	K19/2RAA002209	Carbon fixed: RD25S, 15 Kohm ±5%
R13 and R14	K19/2RBA001802	Metal fixed: RSP2B 3R3, 3.3 ohms ±5%
R15	K19/2RBD004043	Metal fixed: RNF1/4C3, 51 Kohm ±1%
R16	K19/	Metal fixed: RNF1/4C3, 24 Kohm ±1%
R17	K19/	Metal fixed: RNF1/4C3, 27 Kohm ±1%
----- SWITCHES -----		
S1	K19/	SRP119

*COMPONENTS ADDED, DELETED OR CHANGED BY PRODUCTION CHANGES

COMPONENT SIDE

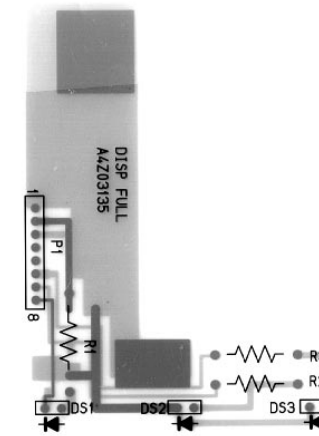

(SA A3Z033028)
(TA A3Z033028)

SOLDER SIDE



(SB A3Z033028)
(TB A3Z033028)

DISPLAY FULL BOARD

COMPONENT SIDE

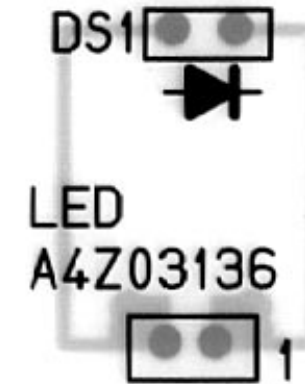

(SA A3Z033028)
(TA A3Z033028)

SOLDER SIDE

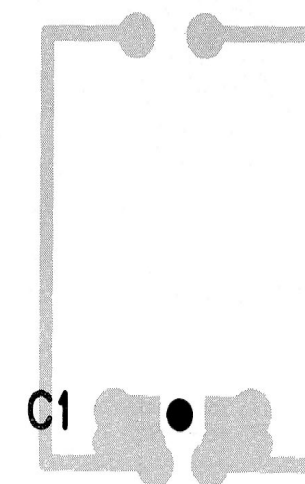

(SB A3Z033028)
(TB A3Z033028)

LED BOARD

COMPONENT & SOLDER SIDE

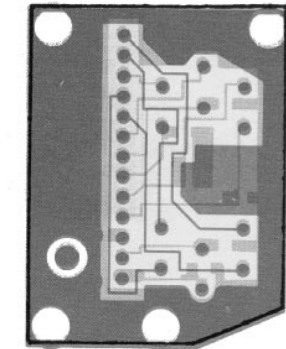

UDC BOARD

DISPLAY FULL BOARD
LED BOARD
UDC BOARD

SOLDER SIDE

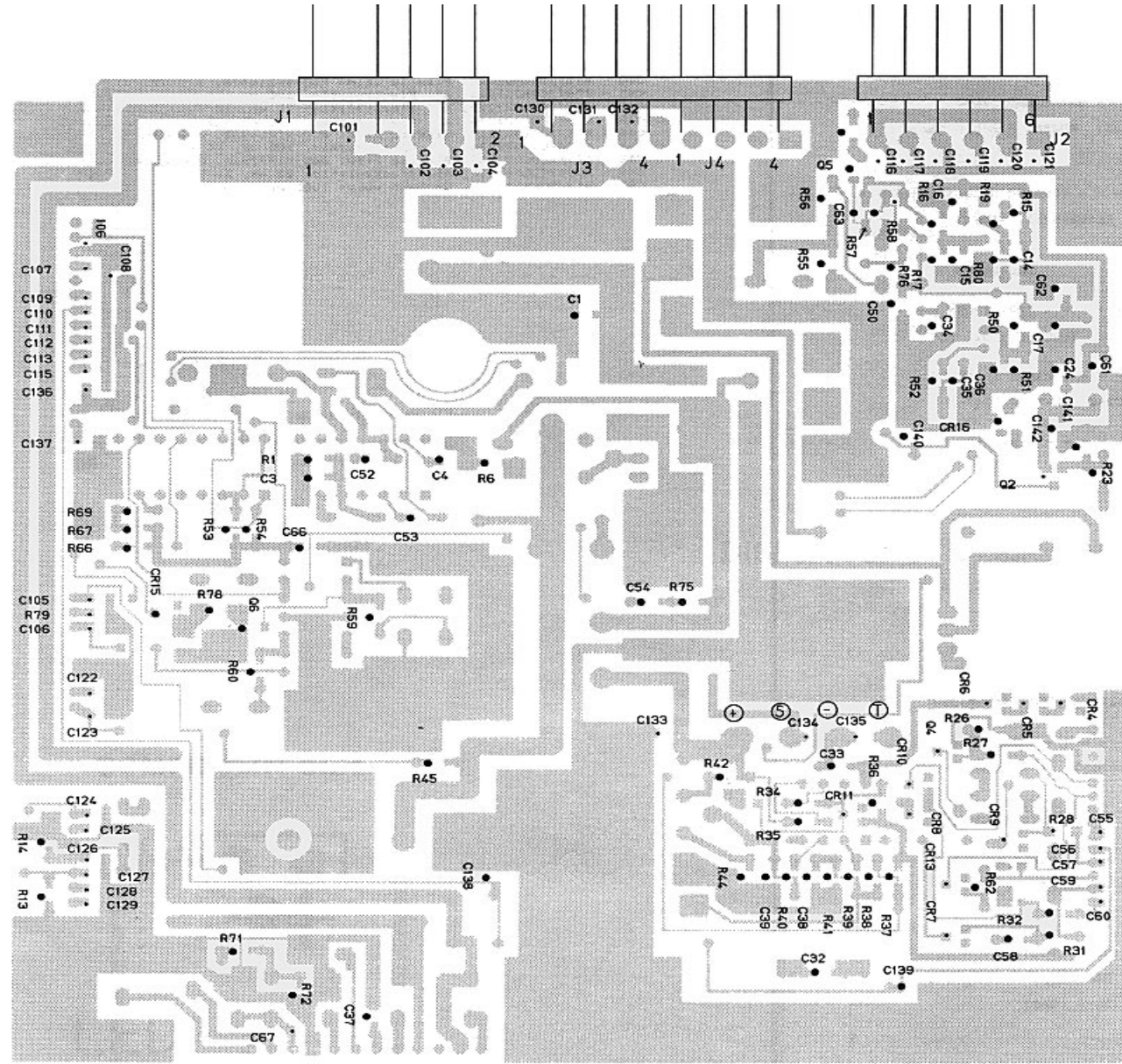

(SB A3Z03063)
(TB A3Z03063A)

COMPONENT SIDE

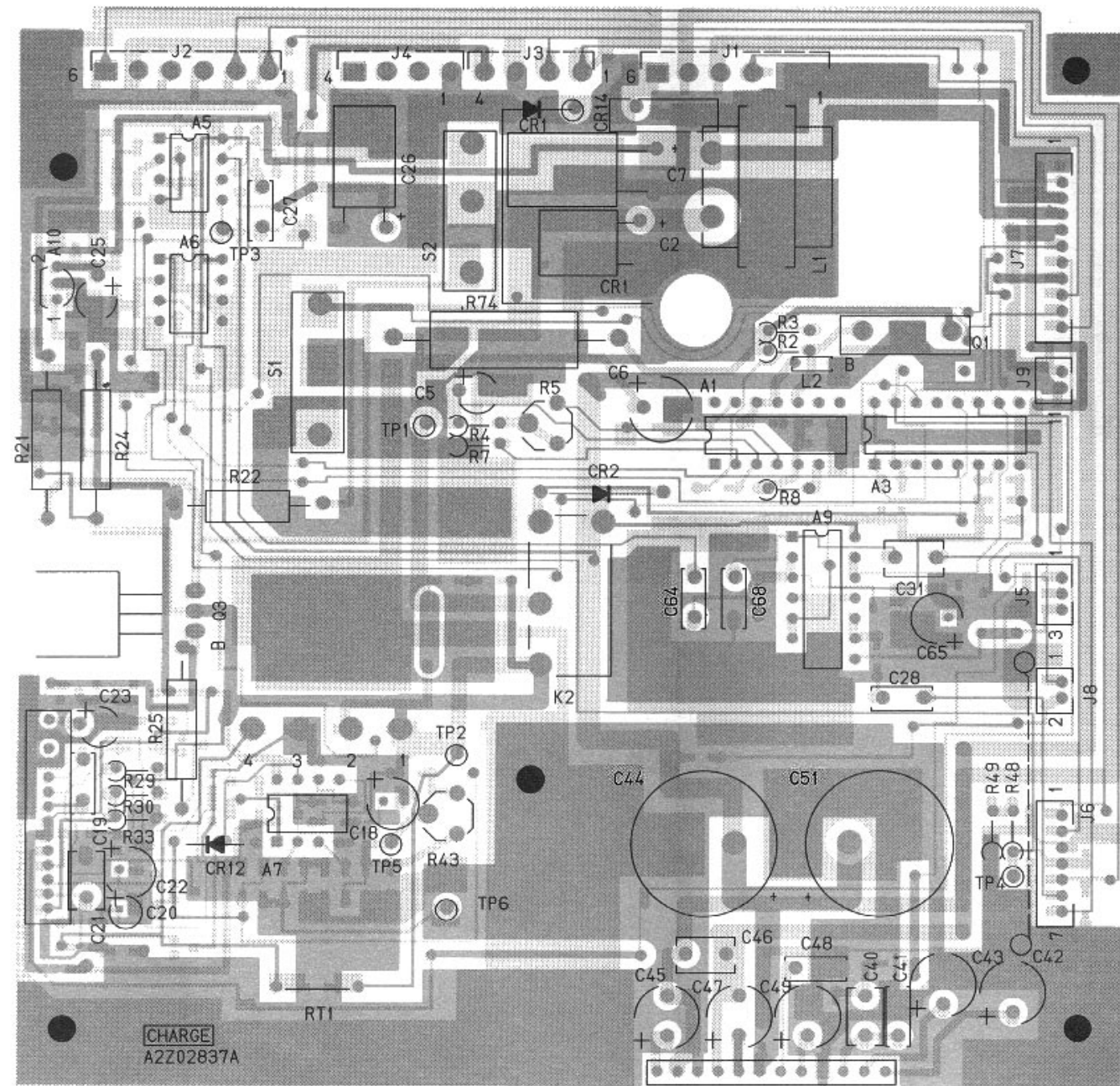

(SA A3Z03063)
(TA A3Z03063A)

CHARGER BOARD
19B801507P1

VEHICULAR CHARGER
(15W AUDIO AMP)
198801507P1
ISSUE 3

SYMBOL	GE PART NO.	DESCRIPTION
----- INTEGRATED CIRCUITS -----		
A1	K19/2AAB021012	V-REG HA17723C
A3	K19/2AAC021168	TR Array TD82004AD
A5 thru A7	K19/2AAB005141	OP-AMP HA17904CS
A9	K19/2ABC038097	Analog Switch MN4066B
A10	K19/2AAB040252	V-REG AN78L06
A12	K19/2AAA011074	AF AMP AN7163
A13	K19/2AAB035061	HIC HRD2036
----- CAPACITORS -----		
C1	K19/2CAK005503	Ceramic chip: 0.1 uF +80/-20%, 50V
C2	K19/2CBB043304	Al. Electrolytic: 220 uF, 25V
C3	K19/2CAK005503	Ceramic chip: 0.1 uF +80/-20%, 50V
C4	K19/2CAK005383	Ceramic chip: 470 pF ±5%, 50V
C6	K19/2CCC024137	Tantalum: DNIC20M1S, 22 uF, 16V
C8	K19/2CBB042215	Al. Electrolytic: 220 uF, 16V
C7	K19/2CBB043171	Al. Electrolytic: 470 uF, 25V
C14 thru C17	K19/2CAK005503	Ceramic chip: 0.1 uF +80/-20%, 50V
C18	K19/2CBB087152	Al. Electrolytic: 22 uF, 25V
C19	K19/2CAJ031527	Ceramic: RPE113F47250, 0.47 uF
C20	K19/2CBB087251	Al. Electrolytic: 2.2 uF, 50V
C21	K19/2CDC001018	Plastic film: ECQ-VIH104JZ, 0.1 uF
C22	K19/2CCC032155	Tantalum: 0.47 uF, 50V
C23	K19/2CBB087228	Al. Electrolytic: 22 uF, 16V
C24	K19/2CAK005503	Ceramic chip: 0.1 uF +80/-20%, 50V
C25	K19/2CBB087228	Al. Electrolytic: 22 uF, 16V
C26	K19/2CBB043163	Al. Electrolytic: 100 uF, 25V
C27	K19/2CDC001018	Plastic film: ECQ-BIH104JZ, 0.1 uF
C28	K19/2CDC001042	Plastic film: ECQ-VIH224JZ, 0.22 uF
C31	K19/2CCC032270	Tantalum: 1 uF, 35V
C32	K19/2CAK005383	Ceramic chip: 1000 pF ±10%, 50V (2x1.6)
C33 thru C36	K19/2CAK005503	Ceramic chip: 0.1 uF +80/-20%, 50V
C38 and C39	K19/2CAK005503	Ceramic chip: 0.1 uF +80/-20%, 50V
C40	K19/2CCC032452	Tantalum: 1 uF, 50V
C41	K19/2CDC001095	Plastic film: ECQ-VIH152JZ, 1500 pF
C42	K19/2CBB043361	Al. Electrolytic: 22 uF, 25V
C43	K19/2CDC001067	Plastic film: 0.01 uF
C44	K19/2CBB083037	Al. Electrolytic: 4700 uF, 25V
C45	K19/2CBB043378	Al. Electrolytic: 47 uF, 25V
C47	K19/2CBB043378	Al. Electrolytic: 100 uF, 16V
C48	K19/2CBB043378	Al. Electrolytic: 100 uF, 16V
C49	K19/2CDC001067	Plastic Film: 0.01 uF

*COMPONENTS ADDED, DELETED OR CHANGED BY PRODUCTION CHANGES

SYMBOL	GE PART NO.	DESCRIPTION
C50	K19/2CAK005503	Ceramic chip: 0.1 uF +80/-20%, 50V
C51	K19/2CBB083037	Al. Electrolytic: 4700 uF, 25V
C52 and C53	K19/2CAK005383	Ceramic chip: 1000 pF ±10%, 50V (3.2x1.6)
C54	K19/2CAK005503	Ceramic chip: 0.1 uF +80/-20%, 50V
C55 thru C61	K19/2CAK013127	Ceramic chip: 1000 pF ±10%, 50V (2x1.2)
C62	K19/2CAK005383	Ceramic chip: 1000 pF ±10%, 50V (3.2x1.6)
C63	K19/2CAK005474	Ceramic chip: 100 pF ±10%, 50V (2x1.2)
C64	K19/2CDC001042	Plastic film: ECQ-VIH224JZ, 0.22 uF
C65	K19/2CCP001504	Tantalum: 4.7 uF, 35V
C66	K19/2CAK005503	Ceramic chip: 0.1 uF +80/-20%, 50V
C67	K19/2CAK013127	Ceramic chip: 1000 pF ±10%, 50V (2x1.2)
C68	K19/2CDC001075	Plastic film: ECQ-B1R472JZ, 4700 pF
C70	K19/2CDC001018	Plastic film: 0.1 uF
C71	K19/2CDC001018	Plastic film: 0.1 uF
C101 thru C104	K19/2CAK013127	Ceramic chip: 1000 pF ±10%, 50V (2x1.2)
C105 and C106	K19/2CAK005474	Ceramic chip: 100 pF ±10%, 50V (2x1.2)
C107 thru C110	K19/2CAK013127	Ceramic chip: 1000 pF ±10%, 50V (2x1.2)
C117	K19/2CAK005474	Ceramic chip: 100 pF ±10%, 50V (2x1.2)
C119 and C120	K19/2CAK013127	Ceramic chip: 1000 pF ±10%, 50V (2x1.2)
C121	K19/2CAK005474	Ceramic chip: 100 pF ±10%, 50V (2x1.2)
C122 thru C129	K19/2CAK013127	Ceramic chip: 1000 pF ±10%, 50V (2x1.2)
C131 and C132	K19/2CAK013127	Ceramic chip: 1000 pF ±10%, 50V (2x1.2)
C133 thru C135	K19/2CAK005383	Ceramic chip: 1000 pF ±10%, 50V (3.2x1.6)
C136 and C137	K19/2CAK013127	Ceramic chip: 1000 pF ±10%, 50V (2x1.2)
C140 thru C142	K19/2CAK005383	Ceramic chip: 1000 pF ±10%, 50V (3.2x1.6)
CA1	K19/2WBE010461	IL-S-28-S2C2-S L=200mm A4WX1801
----- DIODES -----		
CR1	K19/2QBC008129	811B
CR2	K19/2QBC008319	V06C
CR4 thru CR11	K19/2QRF003029	1S2835-T1
CR12	K19/2QRB001737	HZ-7B-1
CR13	K19/2QRF003029	1S2835-T1
CR14	K19/2QBD011429	PRZ-M10DK220
CR15 and CR16	K19/2QRF003029	1S2835-T1
----- CONNECTORS -----		
J1	K19/2PDA020172	5278-05A
J2	K19/2PDA020123	5274-06A
J3 and J4	K19/2PDA020107	5074-04A
J5	K19/2PDA020074	IL-S-3P-S2T2-EF

SYMBOL	GE PART NO.	DESCRIPTION
J6	K19/2PDA029037	IL-S-7P-S2T2-EF
J7	K19/2PDA012740	IL-S-11P-S2T2-EF
J8 and J9	K19/2PDA029038	IL-S-2P-S2T2-EF
----- RELAYS -----		
K2	K19/2KBA003800	GGB-1003H
----- INDUCTORS -----		
L1	K19/2LAA024083	A4ZX00289
L2	K19/2LAB021617	KE05407
----- TRANSISTORS -----		
Q1	K19/2QAB010300	2SD1148-0
Q2	K19/2QAD001018	2SA1052 NCTL
Q3	K19/2QAB008239	2SB553Y
Q4	K19/2QAD001158	2SC2618 NCTL
Q5	K19/2QAC001092	2SK508
Q6	K19/2QAD001158	2SC2618 NCTL
----- RESISTORS -----		
R1	K19/2RGC001213	Square chip: 10 Kohms ±5%
R2	K19/2RAB001175	Carbon fixed: RD25U, 1 Kohms ±5%
R3	K19/2RBD004019	Metal fixed: RNF1/4C3, 1 Kohms ±1%
R4	K19/2RAB001209	Carbon fixed: RD25U, 3.9 Kohms ±5%
R5	K19/2RFB017043	Variable: RG86-FAN, 3 Kohms ±5%
R6	K19/2RGC001213	Square chip: 10 Kohms
R7	K19/2RBD004027	Metal fixed: RNF1/4C3, 13 Kohms ±1%
R8	K19/2RAB001571	Carbon fixed: RD25U, 4.3 Kohms ±5%
R13	K19/2RGC001155	Square chip: 1 Kohms ±5%
R14	K19/2RGC004498	Square chip: 1 Kohms ±5%
R15 thru R17	K19/2RGC001213	Square chip: 10 Kohms ±5%
R19	K19/2RGC001015	Square chip: 0 ohms ±5%
R21	K19/2RBA001180	Metal fixed: RSP1B, 4.7 ohms ±5%
R22	K19/2RBA004624	Metal fixed: RSP1/2B, 8.2 ohms ±5%
R23	K19/2RGC001155	Square chip: 1 Kohms ±5%
R24	K19/2RBD003045	RSW2F851QJ, 51 ohms ±5%
R25	K19/2RBA001455	Metal fixed: RSP1B, 560 ohms ±5%
R26	K19/2RGC001213	Square chip: 10 Kohms ±5%
R27	K19/2RGC001205	Square chip: 6.8 Kohms ±5%
R28	K19/2RGC001023	Square chip: 10 ohms ±5%
R29	K19/2RBD004035	Metal fixed: RNF1/4C3, 100 Kohms ±1%
R30	K19/2RBD004043	Metal fixed: RNF1/4C3, 51 Kohms ±1%
R31	K19/2RGC001197	Square chip: 4.7 Kohms ±5%
R32	K19/2RGC001288	Square chip: 68 Kohms ±5%
R33	K19/2RBD004068	Metal fixed: RNF1/4C3, 120 Kohms ±1%
R34 and R35	K19/2RGC001304	Square chip: 100 Kohms ±5%
R36	K19/2RGC001346	Square chip: 470 Kohms ±5%
R37	K19/2RGC001171	Square chip: 2.2 Kohms ±5%
R38	K19/2RGC001197	Square chip: 4.7 Kohms ±5%
R39 and R40	K19/2RGC001304	Square chip: 100 Kohms ±5%
R41	K19/2RGC001213	Square chip: 10 Kohms ±5%

SYMBOL	GE PART NO.	DESCRIPTION
R42	K19/2RGC001171	Square chip: 2.2 Kohms ±5%
R43	K19/2RFB017049	Variable: RG86-FAN, 1 Kohms ±5%
R44	K19/2RGC001171	Square chip: 2.2 Kohms ±5%
R45	K19/2RGC001155	Square chip: 1 Kohms ±5%
R48	K19/2RAB001217	Carbon fixed: RD25U, 4.7 Kohms ±5%
R49	K19/2RAB001597	Carbon fixed: RD25U, 680 ohms ±5%
R50	K19/2RGC001213	Square chip: 10 Kohms ±5%
R51	K19/2RGC001171	Square chip: 2.2 Kohms ±5%
R52	K19/2RGC001270	Square chip: 47 Kohms ±5%
R53 and R54	K19/2RGC001213	Square chip: 10 Kohms ±5%
R55	K19/2RGC001163	Square chip: 1.5 Kohms ±5%
R56	K19/2RGC001353	Square chip: 620 ohms ±5%
R57 and R58	K19/2RGC001254	Square chip: 33 Kohms ±5%
R59	K19/2RGC001213	Square chip: 10 Kohms ±5%
R60	K19/2RGC001171	Square chip: 2.2 Kohms ±5%
R62	K19/2RGC001312	Square chip: 150 Kohms ±5%
R66 and R67	K19/2RGC001213	Square chip: 10 Kohms ±5%
R69	K19/2RGC001254	Square chip: 33 Kohms ±5%
R71	K19/2RGC001221	Square chip: 15 Kohms ±5%
R72	K19/2RGC001304	Square chip: 100 Kohms ±5%
R74	K19/2RDA073021	Wire wound: M-3, 0.33 ohms ±5%
R75	K19/2RGC001148	Square chip: 680 ohms ±5%
R77	K19/2RGC001320	Square chip: 220 Kohms ±5%
R78	K19/2RGC001221	Square chip: 15 Kohms ±5%
R79	K19/2RGC001098	Square chip: 22 ohms ±5%
R80	K19/2RGC001197	Square chip: 4.7 Kohms ±5%
R87	K19/	Metal film: 2.2 ohms
R88	K19/	Metal film: 2.2 ohms
----- THERMISTORS -----		
RT1	K19/2QBD016121	NTCD540204AG5090C, 50 Kohms, A4WX01493
----- SWITCHES -----		
S1 thru S3	K19/2KKA001718	SS-5GL3004
----- TERMINALS -----		
TB1	K19/	Terminal
----- TEST POINTS -----		
TP1 thru TP8	K19/2PYD002718	75404-001
----- MISCELLANEOUS -----		
Z1	K19/2QYV013059	Silicon rubber 30P-TO-3PP. (Used for Q1).
Z2	K19/2QYV001179	Silicon rubber AC255. (Used for A12).
Z3	K19/2QYV013034	Silicon rubber 30P-TO-220. (Used for Q3).
Z4	K19/2QYV002994	Isolated washer YC40B. (Used for Q3).
DISPLAY FULL		
----- CAPACITORS -----		
C1 thru C4	K19/2CAK013127	Ceramic chip: 1000 pF ±10%, 50V

SYMBOL	GE PART NO.	DESCRIPTION
CA1	K19/2WHB010388	----- CABLE ASSEMBLY ----- IL-T-8P-S2C2-W IL-S-8S-S2C2-S
CA2	K19/2WHB010453	IL-S-8S-S2C2-S L=140mm A4WFO1800
		----- DIODES -----
DS1	K19/2HACH01013	LED LD-201VR
DS2	K19/2HACH010127	LED LD-201WG
DS3	K19/2HACH001013	LED LD-201VR
		----- RESISTORS -----
R1 thru R3	K19/2RAA0002059	Carbon fixed: RD25S, 1 Kohm ±5%
		----- VOLTAGE REGULATORS -----
VR1	K19/2RF	Variable: RK163-5M1111-10EA
		----- LMD BOARD -----
		----- CAPACITORS -----
C1	K19/2CAK013127	Ceramic chip: 1000 pF ±10%, 50V
		----- CABLE ASSEMBLY -----
CA1	K19/2WHB010412	IL-T-2P-S2C2-W IL-S-2S-S2C2-S
		----- DIODES -----
DS1	K19/2HACH010135	LED LD-201VR
		----- UDC BOARD -----
		----- CAPACITORS -----
C2 and C3	K19/2CAK013127	Ceramic chip: 1000 pF ±10%, 50V
		----- CABLE ASSEMBLY -----
CA1	K19/2WHB010370	IL-T-7P-S2C2-W IL-S-7S-S2C2-S
CA2	K19/2WHC010116	TWC-PJ-1.5KV r=30CM A4WFO1799
		----- CONNECTORS -----
P1	K19/2PCB003377	Y-73B A4WFO7850
		----- CHASSIS ACCESSORIES -----
		----- CABLE ASSEMBLY -----
CA1	K19/2WHB010446	Power cable A4WFO1795
		----- MISCELLANEOUS -----
Z11	K19/2PGA004112	Terminal V1.25-b (Red)
Z12	K19/2PGA002838	Terminal V1.25-b (Red)
Z13	K19/	Terminal V1.25-b (Red)

PRODUCTION CHANGES
Changes in the equipment to improve performance or to simplify circuits are identified by a "Revision Letter", which is stamped after the model number of the unit. The revision stamped on the unit includes all previous revisions. Refer to the Parts List for the description of parts affected by these revisions.

RRV. A - VEHICULAR CHARGER BOARD 198801507P1
To increase trickle charge current changed R24. Old part number was:
R24 - K19/2RAA001331, Metal: RSF12, 120 ohms ± 5%.

Other production changes cover the use of a new audio amplifier A12. To incorporate this new amplifier changed A12, C40, C42, C43, C45, C47, C49, C49 and C67. Added C70, C71, R87 and R88 and deleted C46. Old part numbers were:

- A12 - K19/2AAJ007099, AF AMP: RN7160.
- C40 - K19/2CDB001019, Plastic film: ECQ-V1H104J2, 0.1 uF.
- C42 - K19/2CBB087236, Al. Electrolytic: 100 uF, 16 V.
- C43 - K19/2CBB087228, Al. Electrolytic: 22 uF, 16 V.
- C45 - K19/2CBB087236, Al. Electrolytic: 100 uF, 16 V.
- C46 - K19/2CDB001018, Plastic film: ECQ-V1H104J2, 0.1 uF.
- C47 - K19/2CBB087236, Al. Electrolytic: 100 uF, 16 V.
- C49 - K19/2CDB001187, Plastic film: ECQ-V1M223J2, 0.022 uF.
- C67 - K19/2CBB087228, Al. Electrolytic: 22 uF, 16 V.
- C67 - K19/2CAK013127, Ceramic chip: 1000 pF ±10%, 50 V.

SOLDER SIDE

COMPONENT SIDE

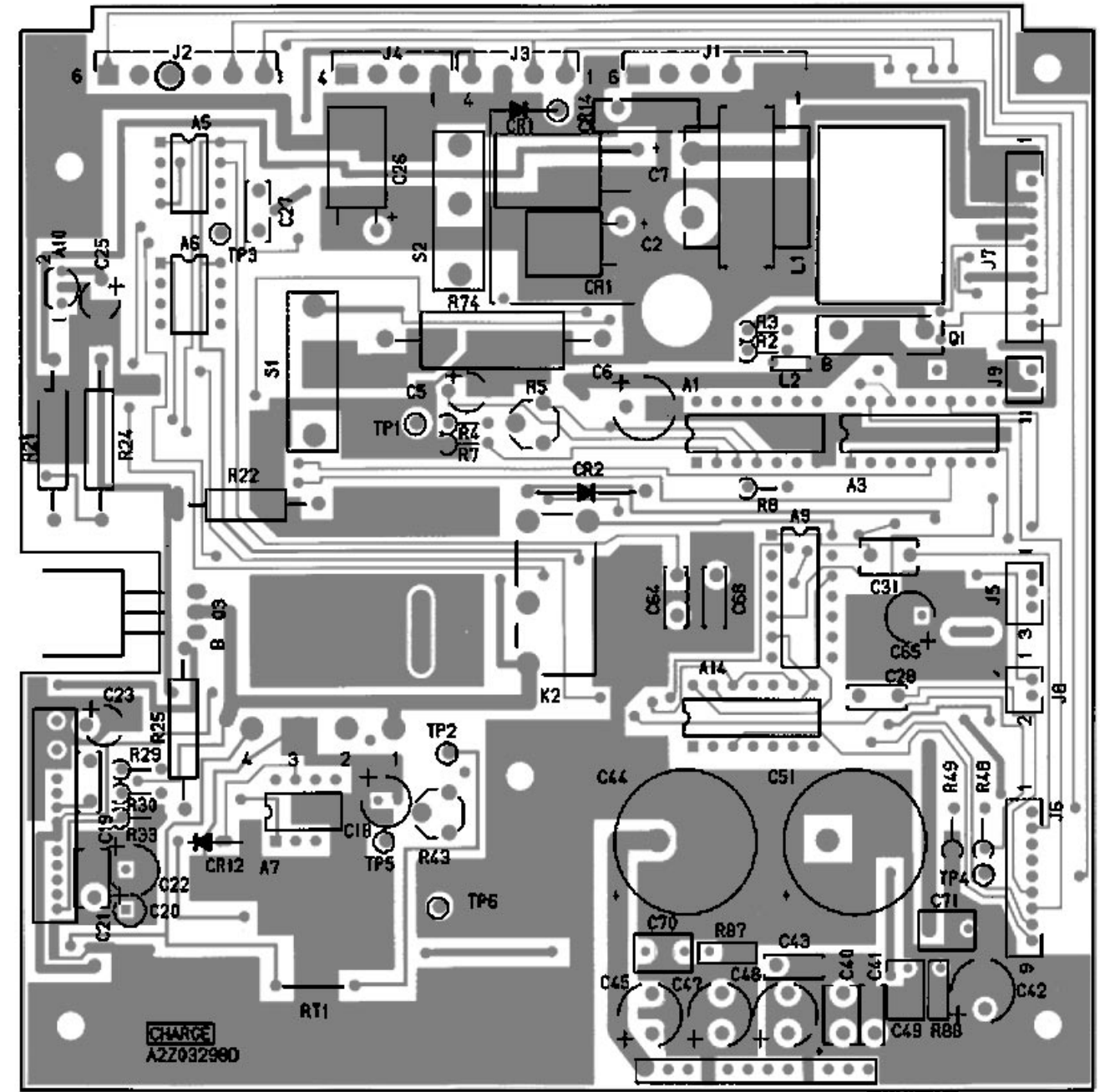
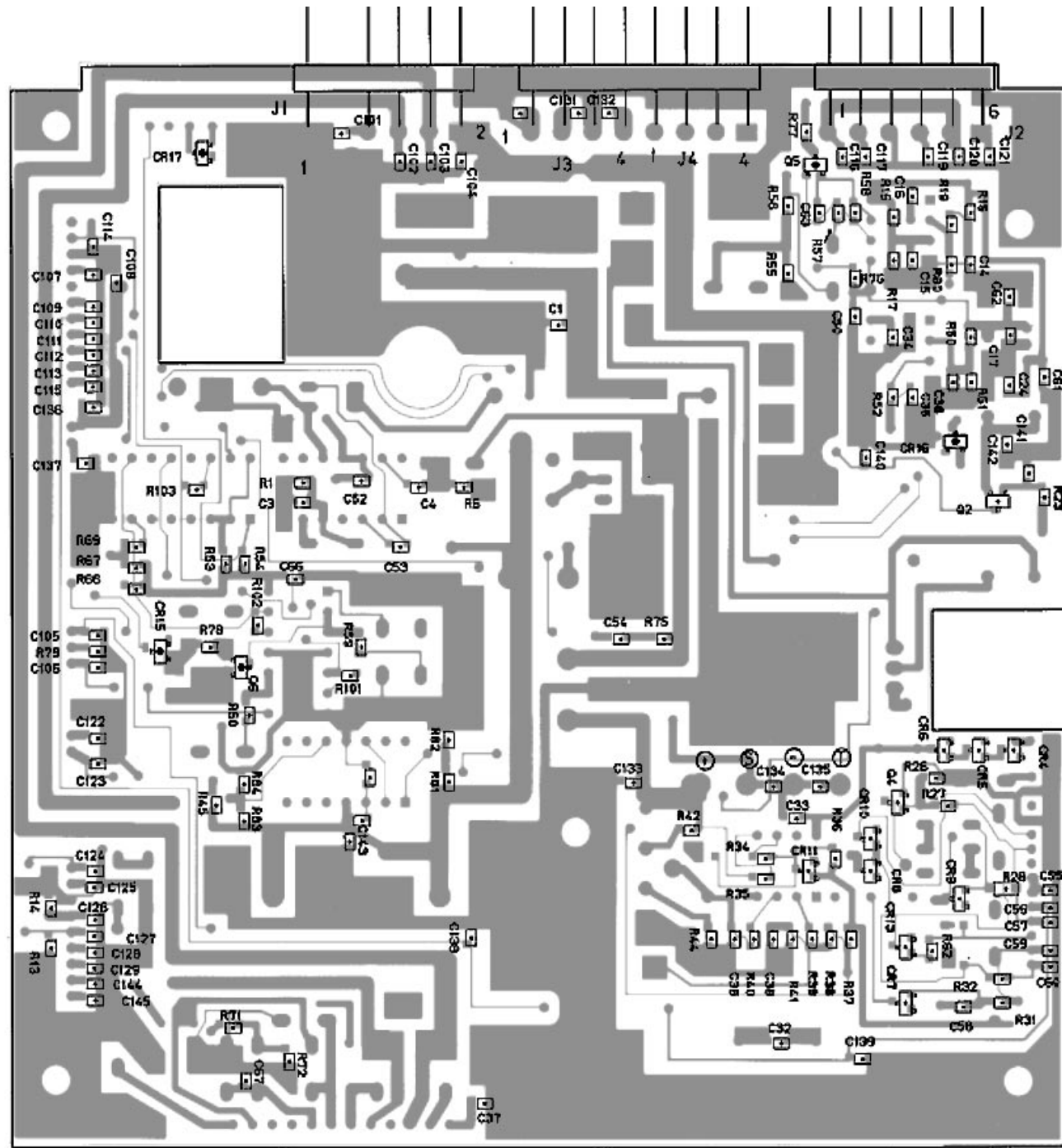

(SB A3Z03302D
(TB A3Z03302D)

(SA A3Z03302D
(TA A3Z03302D)

CHARGER BOARD
19B801507P4

VEHICULAR CHARGER
(15W AUDIO AMP)
198601507P4
ISSUE 2

SYMBOL	GE PART NO.	DESCRIPTION
----- INTEGRATED CIRCUITS -----		
A1	K19/2AAK021012	V-REG HA17723G
A3	K19/2AAG021168	TR Array TDE2004AP
A5 thru A7	K19/2AAB006141	OP-AMP HA17004GS
A9	K19/2ABC039087	Analog Switch MN4008B
A10	K19/2AAR049252	V-REG AN78L06
A12	K19/2AAAO11074	AF AMP AN716S
A13	K19/2AAR036081	HIC H8D2036
A14	K19/2AAB020058	OP-AMP BA10324
----- CAPACITORS -----		
C1	K19/2CAK013010	Ceramic chip: 0.1 uF +80/-20%, 25V
C2	K19/2CBB043304	Al. Electrolytic: 220 uF, 25V
C3	K19/2CAK013010	Ceramic chip: 0.1 uF +80/-20%, 25V
C4	K19/2CAK013226	Ceramic chip: 470 pF ±5%, 50V
C5	K19/2CCC024137	Tantalum: DMIC220M19, 22 uF, 16V
C6	K19/2CBB042218	Al. Electrolytic: 220 uF, 16V
C7	K19/2CBB043171	Al. Electrolytic: 470 uF, 25V
C14 thru C17	K19/2CAK013010	Ceramic chip: 0.1 uF +80/-20%, 25V
C18	K19/2CBB087182	Al. Electrolytic: 22 uF, 25V
C19	K19/2CAJ031527	Ceramic: RPE113F474250, 0.47 uF
C20	K19/2CBB087251	Al. Electrolytic: 2.2 uF, 50V
C21	K19/2CDC001018	Plastic film: ECQ-V1H104JZ, 0.1 uF
C22	K19/2CCC021555	Tantalum: 0.47 uF, 50V
C23	K19/2CBB087228	Al. Electrolytic: 22 uF, 16V
C24	K19/2CAK013010	Ceramic chip: 0.1 uF +80/-20%, 25V
C25	K19/2CBB087228	Al. Electrolytic: 22 uF, 16V
C26	K19/2CBB043103	Al. Electrolytic: 100 uF, 25V
C27	K19/2CDC001018	Plastic film: ECQ-B1H104JZ, 0.1 uF
C28	K19/2CDC001042	Plastic film: ECQ-V1H224JZ, 0.22 uF
C31	K19/2CCC032270	Tantalum: 1 uF, 35V
C32	K19/2CAK013127	Ceramic chip: 1000 pF ±10%, 50V (3.2x1.6)
C33 thru C36	K19/2CAK013010	Ceramic chip: 0.1 uF +80/-20%, 25V
C38 and C39	K19/2CAK013010	Ceramic chip: 0.1 uF +80/-20%, 25V
C40	K19/2CCC032452	Tantalum: 0.1 uF, 50V
C41	K19/2CDC001095	Plastic film: ECQ-V1H152JZ, 1500 pF
C42	K19/2CBB043361	Al. Electrolytic: 22 uF, 25V
C43	K19/2CDC001067	Plastic film: 0.01 uF
C44	K19/2CBB083037	Al. Electrolytic: 4700 uF, 25V
C45	K19/2CBB043379	Al. Electrolytic: 47 uF, 25V
C47	K19/2CBB043379	Al. Electrolytic: 47 uF, 25V
C48	K19/2CBB043379	Al. Electrolytic: 47 uF, 25V
C49	K19/2CDC001067	Plastic film: 0.01 uF

SYMBOL	GE PART NO.	DESCRIPTION
C50	K19/2CAK013010	Ceramic chip: 0.1 uF +80/-20%, 25V
C51	K19/2CBB083037	Al. Electrolytic: 4700 uF, 25V
C52 and C53	K19/2CAK005383	Ceramic chip: 1000 pF ±10%, 50V (3.2x1.6)
C54	K19/2CAK005503	Ceramic chip: 0.1 uF +80/-20%, 50V
C55 thru C62	K19/2CAK013127	Ceramic chip: 1000 pF ±10%, 50V (2x1.2)
C63	K19/2CAK005909	Ceramic chip: 100 pF ±50%, 50V (2x1.2)
C64	K19/2CDC001042	Plastic film: ECQ-V1H224JZ, 0.22 uF
C65	K19/2CCC021555	Tantalum: .47 uF, ±20% 35V
C66	K19/2CAK013010	Ceramic chip: 0.1 uF +80/-20%, 25V
C67	K19/2CAK013127	Ceramic chip: 1000 pF ±10%, 50V (2x1.2)
C68	K19/2CDC001075	Plastic film: ECQ-B1H472JZ, 4700 pF
C70	K19/2CDC001018	Plastic film: 0.1 uF
C71	K19/2CDC001018	Plastic film: 0.1 uF
C101 thru C104	K19/2CAK013127	Ceramic chip: 1000 pF ±10%, 50V (2x1.2)
C105 and C106	K19/2CAK005909	Ceramic chip: 100 pF ±5%, 50V (2x1.2)
C107 thru C116	K19/2CAK013127	Ceramic chip: 1000 pF ±10%, 50V (2x1.2)
C117	K19/2CAK005909	Ceramic chip: 100 pF ±5%, 50V (2x1.2)
C119 and C120	K19/2CAK013127	Ceramic chip: 1000 pF ±10%, 50V (2x1.2)
C121	K19/2CAK005909	Ceramic chip: 100 pF ±5%, 50V (2x1.2)
C122 thru C129	K19/2CAK013127	Ceramic chip: 1000 pF ±10%, 50V (2x1.2)
C131 and C132	K19/2CAK013127	Ceramic chip: 1000 pF ±10%, 50V (2x1.2)
C133 thru C135	K19/2CAK005383	Ceramic chip: 1000 pF ±10%, 50V (3.2x1.6)
C136 and C137	K19/2CAK013127	Ceramic chip: 1000 pF ±10%, 50V (2x1.2)
C140 thru C142	K19/2CAK013127	Ceramic chip: 1000 pF ±10%, 50V (3.2x1.6)
----- CABLE ASSEMBLY -----		
CA1	K19/2WNE010461	IL-S-28-S2C2-S L=200mm A4WX01801
----- DIODES -----		
CR1	K19/2QBC008120	611B
CR2	K19/2QBC008319	V06C
CR4 thru CR11	K19/2QBE003029	1S2835-T1
CR12	K19/2QBB001737	HZ-7B-1
CR13	K19/2QBE003029	1S2835-T1
CR14	K19/2QBD011429	ERZ-W10DK220
CR15 thru CR17	K19/2QBE003029	1S2835-T1
----- CONNECTORS -----		
J1	K19/2PDA020172	5278-05A
J2	K19/2PDA020123	5274-06A
J3 and J4	K19/2PDA020107	5274-04A
J5	K19/2PDA029074	IL-S-3P-S2T2-EF

SYMBOL	GE PART NO.	DESCRIPTION
J6	K19/2PDA029033	IL-S-9P-S2T2-EF
J7	K19/2PDA012740	IL-S-11P-S2T2-EF
J8 and J9	K19/2PDA029058	IL-S-2P-S2T2-EF
----- RELAYS -----		
K2	K19/2KBA003800	06B-1003H
----- INDUCTORS -----		
L1	K19/2LAA024083	A42X00299
L2	K19/2LAB021617	KE05407
----- TRANSISTORS -----		
Q1	K19/2QAB010300	2SD1148-0
Q2	K19/2QAD001018	2SA1052 MCTL
Q3	K19/2QAB008239	2SB553Y
Q4	K19/2QAD001158	2SC2618 RCTL
Q5	K19/2QAC001092	2SK508
Q6	K19/2QAD001158	2SC2618 RCTL
----- RESISTORS -----		
R1	K19/2RGC006246	Square chip: 10 Kohms ±5%
R2	K19/2RBA001175	Carbon fixed: RD25U, 1 Kohms ±5%
R3	K19/2RBD004019	Metal fixed: RNF1/4C3, 1 Kohms ±1%
R4	K19/2RBA001209	Carbon fixed: RD25U, 3.9 Kohms ±5%
R5	K19/2RFB009828	Variable: RGS0-FAN, 3 Kohms ±5%
R6	K19/2RGC006246	Square chip: 10 Kohms ±5%
R7	K19/2RBD004027	Metal fixed: RNF1/4C3, 13 Kohms ±1%
R8	K19/2RBA001571	Carbon fixed: RD25U, 4.3 Kohms ±5%
R13	K19/2RGC006238	Square chip: 1 Kohms ±5%
R14	K19/2RGC006831	Square chip: 1 Kohms ±5%
R15 thru R17	K19/2RGC006246	Square chip: 10 Kohms ±5%
R19	K19/2RGC001015	Square chip: 0 ohms ±5%
R21	K19/2RBA001190	Metal fixed: RSP1B, 4.7 ohms ±5%
R22	K19/2RBA004624	Metal fixed: RSP1/2B, 6.2 ohms ±5%
R23	K19/2RGC006238	Square chip: 1 Kohms ±5%
R24	K19/2RBD003045	RSM2FB510J, 51 ohms ±5%
R25	K19/2RBA001455	Metal fixed: RSP1B, 580 ohms ±5%
R26	K19/2RGC006246	Square chip: 10 Kohms ±5%
R27	K19/2RGC006576	Square chip: 6.8 Kohms ±5%
R28	K19/2RGC006212	Square chip: 10 ohms ±5%
R29	K19/2RBD004035	Metal fixed: RNF1/4C3, 100 Kohms ±1%
R30	K19/2RBD004043	Metal fixed: RNF1/4C3, 51 Kohms ±1%
R31	K19/2RGC006402	Square chip: 4.7 Kohms ±5%
R32	K19/2RGC006501	Square chip: 68 Kohms ±5%
R33	K19/2RBD004068	Metal fixed: RNF1/4C3, 120 Kohms ±1%
R34 and R35	K19/2RGC006253	Square chip: 100 Kohms ±5%
R36	K19/2RGC006428	Square chip: 470 Kohms ±5%
R37	K19/2RGC006329	Square chip: 2.2 Kohms ±5%
R38	K19/2RGC006402	Square chip: 4.7 Kohms ±5%
R39 and R40	K19/2RGC006523	Square chip: 100 Kohms ±5%
R41	K19/2RGC006246	Square chip: 10 Kohms ±5%

SYMBOL	GE PART NO.	DESCRIPTION
R42	K19/2RGC006329	Square chip: 2.2 Kohms ±5%
R43	K19/2RFB017046	Variable: RGS0-FAN, 1 Kohms ±5%
R44	K19/2RGC006329	Square chip: 2.2 Kohms ±5%
R45	K19/2RGC006238	Square chip: 1 Kohms ±5%
R48	K19/2RAB001217	Carbon fixed: RD25U, 4.7 Kohms ±5%
R49	K19/2RAB001587	Carbon fixed: RD25U, 680 ohms ±5%
R50	K19/2RGC006246	Square chip: 10 Kohms ±5%
R51	K19/2RGC006329	Square chip: 2.2 Kohms ±5%
R52	K19/2RGC006410	Square chip: 47 Kohms ±5%
R53 and R54	K19/2RGC006246	Square chip: 10 Kohms ±5%
R55	K19/2RGC006279	Square chip: 1.5 Kohms ±5%
R56	K19/2RGC006444	Square chip: 620 ohms ±5%
R57 and R58	K19/2RGC006360	Square chip: 33 Kohms ±5%
R59	K19/2RGC006246	Square chip: 10 Kohms ±5%
R60	K19/2RGC006329	Square chip: 2.2 Kohms ±5%
R62	K19/2RGC006295	Square chip: 150 Kohms ±5%
R66 and R67	K19/2RGC006246	Square chip: 10 Kohms ±5%
R69	K19/2RGC006360	Square chip: 33 Kohms ±5%
R71	K19/2RGC006287	Square chip: 15 Kohms ±5%
R72	K19/2RGC006253	Square chip: 100 Kohms ±5%
R74	K19/2RDA073021	Wire wound: W-3, 0.33 ohms ±5%
R75	K19/2RGC006543	Square chip: 680 ohms ±5%
R77	K19/2RGC006345	Square chip: 220 Kohms ±5%
R78	K19/2RGC006287	Square chip: 15 Kohms ±5%
R79	K19/2RGC006220	Square chip: 22 ohms ±5%
R80	K19/2RGC006402	Square chip: 4.7 Kohms ±5%
R81	K19/2RGC006410	Square chip: 47 Kohms ±5%
R82	K19/2RGC006246	Square chip: 10 Kohms ±5%
R83	K19/2RGC007428	Square chip: 18 Kohms ±5%
R84	K19/2RGC006246	Square chip: 10 Kohms ±5%
R85	K19/2RGC007428	Square chip: 18 Kohms ±5%
R86	K19/2RGC006246	Square chip: 10 Kohms ±5%
R87	K19/	Metal film: 2.2 ohms
R88	K19/	Metal film: 2.2 ohms
----- THERMISTORS -----		
RT1	K19/2QBD016121	NTCS40204AG503GC, 50 Kohms, A4WX01483
----- SWITCHES -----		
S1 thru S5	K19/2EKA001718	SS-5GL3004
----- TERMINALS -----		
TB1	K19/	Terminal
----- TEST POINTS -----		
TP1 thru TP6	K19/2QYD002718	75404-001
----- MISCELLANEOUS -----		
Z1	K19/2QYF013059	Silicon rubber 30F-TO-3PF. (Used for Q1).
Z2	K19/2QYF001179	Silicon rubber AC255. (Used for A12)
Z3	K19/2QYF013034	Silicon rubber 30F-TO-220. (Used for Q3).
Z4	K19/2QYF002094	Isolated washer YC40B. (Used for Q5).

*COMPONENTS ADDED, DELETED OR CHANGED BY PRODUCTION CHANGES

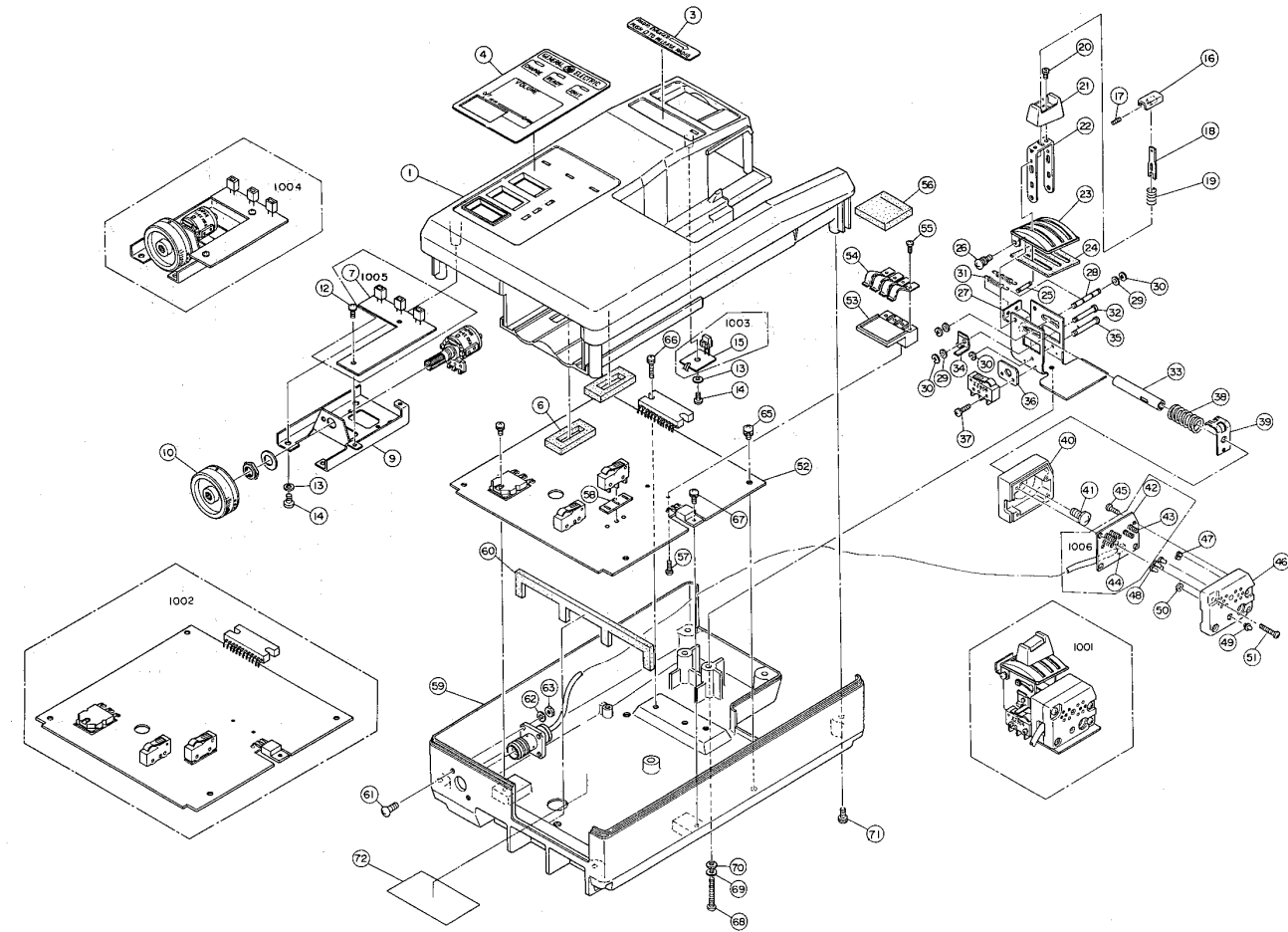

PARTS LIST
 MPD VEHICULAR CHARGER (W/15W)
 K19/A2WL10854
 ISSUE 1

SYMBOL	GE PART NO.	DESCRIPTION
1	K19/A4WL09967	TOP CABINET
2		
3	K19/A4WL09345	LED NAME PLATE
4	K19/A3WL08349	NAME PLATE (15W)
5		
6	K19/A4WL09831	SPONGE FOR SWITCHES
7	K19/A3WL10932	DISP PULL BOARD
8		
9	K19/A3WL09980	FIXING PLATE
10	K19/A4WL08061	KNOB (15W)
11		
12	K19/M2. 6X6	PANHEAD MACHINE SCREWS W/SW & PW
13	K19/M3	SPRING WASHERS
14	K19/M3X6	PANHEAD TAPPING SCREWS
15	K19/A4WL10934	LED BOARD
16	K19/A4WL08850	PUSH BUTTON
17	K19/M2X5	LS
18	K19/A4WL08843	PUSH LEVER
19	K19/A4WL09906	COIL SPRING C
20	K19/M2X3	PANHEAD MACHINE SCREWS
21	K19/A4WL08851	UDC KNOB
22	K19/A4WL08844	LEVER
23	K19/A3WL08874	KNOB CUP
24	K19/A4WL09830	SPONGE COVER
25	K19/A4WL09337	PIN D
26	K19/M2. 6X6	PANHEAD MACHINE SCREWS W/SW & PW
27	K19/A3WL08068	SHELL
28	K19/A4WL09334	PIN A
29	K19/M2.6	PLATE WASHERS
30	K19/L.5	E-RING
31	K19/A4WL09905	COIL SPRING B
32	K19/A4WL09336	PIN C
33	K19/A4WL08074	BAR
34	K19/A4WL09993	PLATE
35	K19/A4WL09335	PIN B
36	K19/A4WL09999	SPACER
37	K19/M2X12	PANHEAD MACHINE SCREWS W/SW & PW
38	K19/A4WL08075	COIL SPRING A
39	K19/A4WL09907	LEAF SPRING
40	K19/A3WL08072	UDC COVER
41	K19/M4X10	PANHEAD MACHINE SCREWS W/SW & PW
42	K19/A4WL10933	UDC PWB
43	K19/A4WL07675	RF SPRINGS
44	K19/A4WL08710	FIXING PLATE FOR WIRE
45	K19/M2X5	PANHEAD TAPPING SCREWS
46	K19/A3WL08071	UDC CASE
47	K19/A4WL07521	UDC CONTACT PINS
48	K19/A4WL08845	EARTH CONTACT PIN

SYMBOL	GE PART NO.	DESCRIPTION
49	K19/A4WL08376	GUIDE PIN
50	K19/2	E-RING
51	K19/M2X8	PANHEAD TAPPING SCREWS
52	K19/A2WL09897	CHARGER PWB
53	K19/A4WL08079	CONTACT PLATE
54	K19/A3WL07862	CONTACT SPRINGS
55	K19/M2X5	PANHEAD TAPPING SCREWS
56	K19/A4WL09832	SPONGE FOR CONTACT
57	K19/M2X8	PANHEAD TAPPING SCREWS
58	K19/A4WL08078	SPACER
59	K19/A1WL08057	CABINET CASE
60	K19/A4WL09833	SPONGE FOR CONNECTOR
61	K19/M2.6X10	COUNTERSUNK HEAD MACHINE SCREWS
62	K19/M2.6	SPRING WASHERS
63	K19/M2.6	NUTS
64		
65	K19/M3X6	PANHEAD MACHINE SCREWS W/SW
66	K19/M3X10	PANHEAD MACHINE SCREWS W/SW & PW
67	K19/M3X8	PANHEAD MACHINE SCREWS W/SW & PW
68	K19/M3X25	PANHEAD MACHINE SCREWS
69	K19/M3	SPRING WASHERS
70	K19/M3	PLATE WASHERS
71	K19/M3X14	PANHEAD MACHINE SCREWS W/SW & PW
		SUB ASSEMBLY PARTS LIST W/15W
1001		The Latch Mechanism Assembly consists of the parts with the following symbol numbers: 16,17,18,19,20,21,22,23,24,25,26,27,28,29,30,31,32,33,34,35,36,37,38,39,40,41,42,43,44,45,46,47,48,49,50, and 51.
1002	K19/A3WL10984	Charger PWB Assembly consist of the parts with symbol numbers 52 and 58.
1003	K19/A3WL10988	LED Board Assembly consist of the part with symbol number 15.
1004		The Volume Switch Assembly consists of the parts with the following symbol numbers: 7,9,10,12,13, and 14.
1005	K19/A4WL10986	Display Full Board Assembly consists of the part with symbol number 7.
1006	K19/A4WL10989	UDC PWB Assembly consists of the parts with symbol numbers 42,43, and 44.

*COMPONENTS ADDED, DELETED OR CHANGED BY PRODUCTION CHANGES

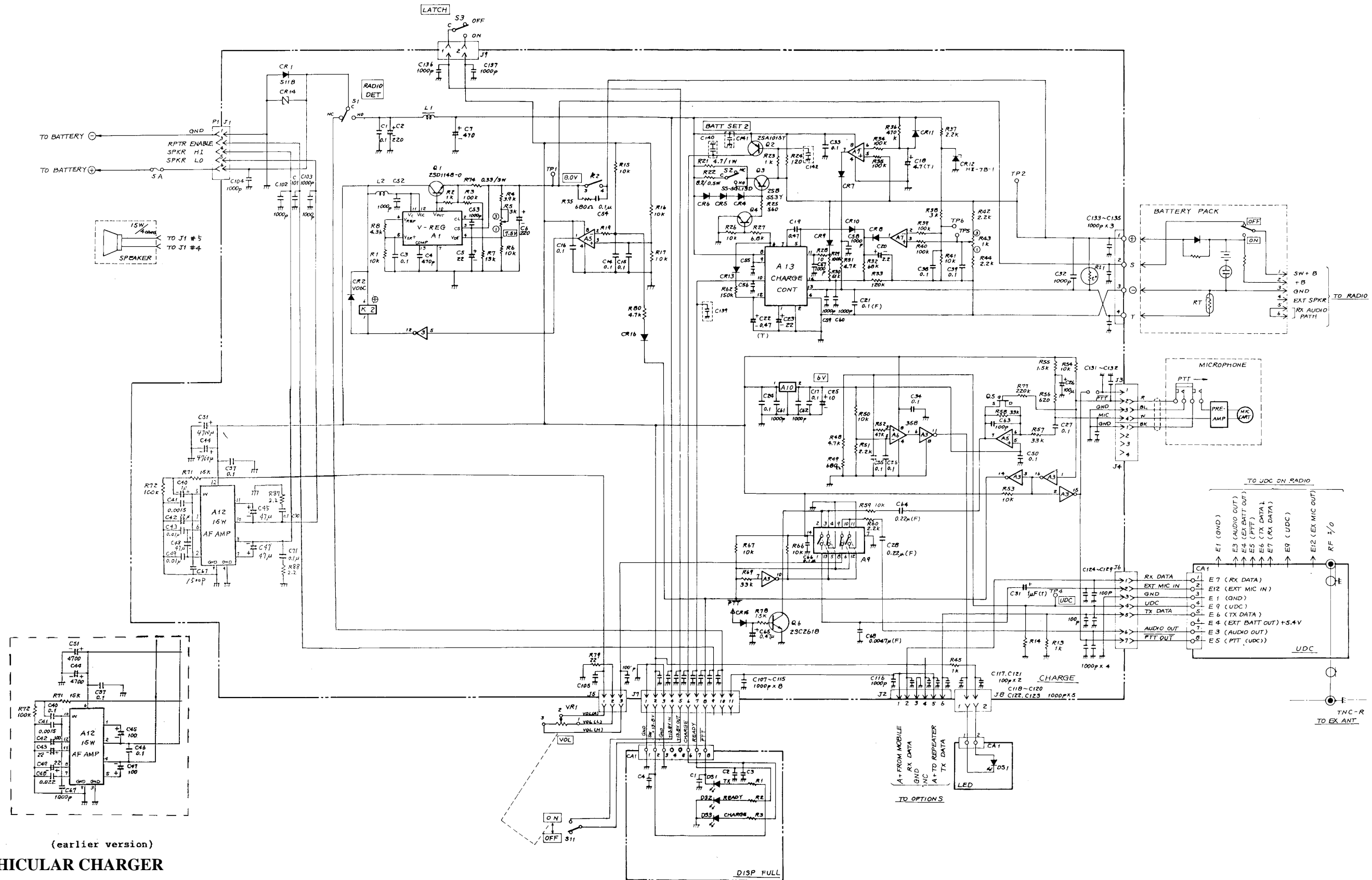

(earlier version)

VEHICULAR CHARGER

19B801507P1

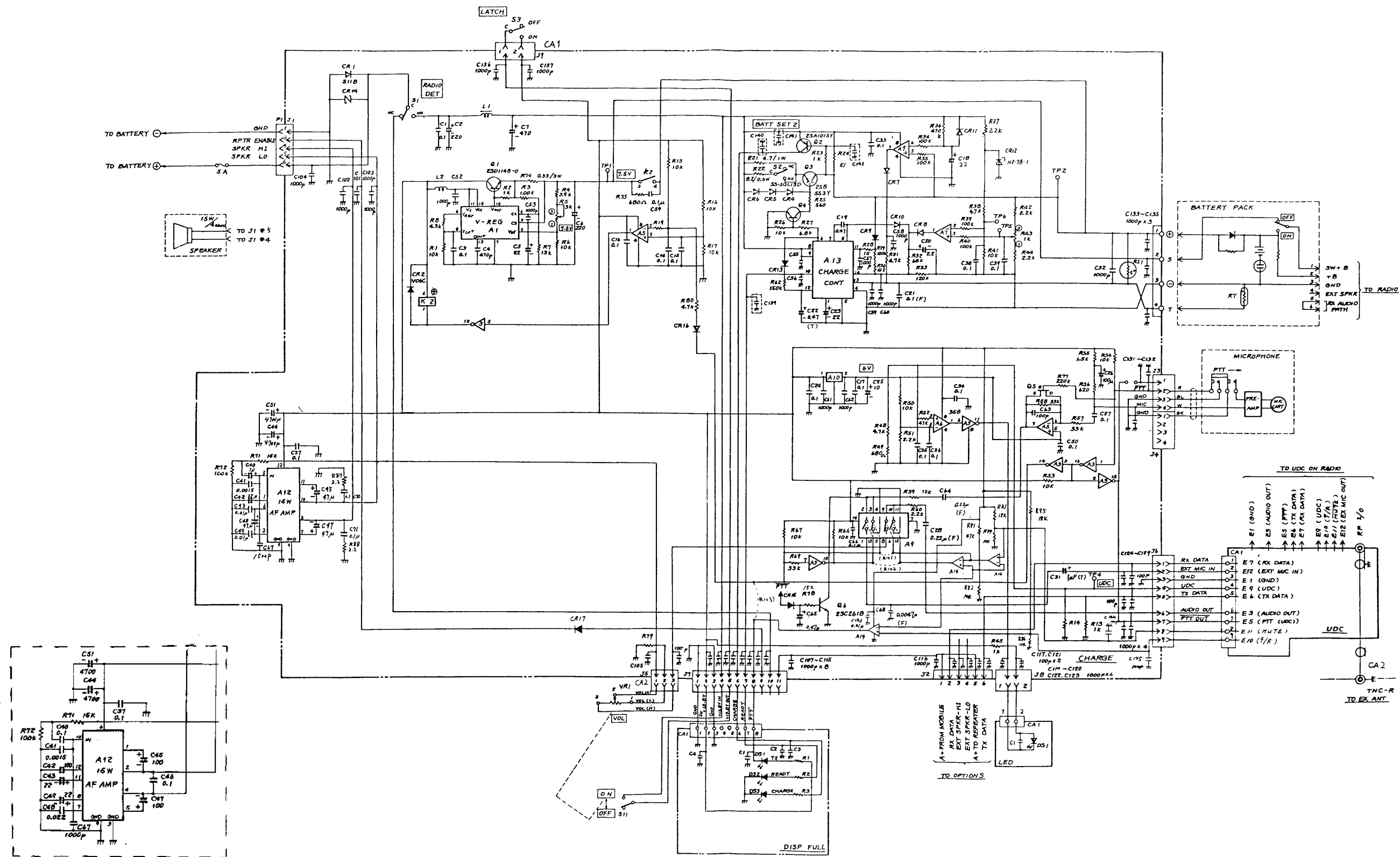

(earlier version)

VEHICULAR CHARGER
19B801507P4