



Mobile Communications



**VEHICULAR CHARGER/
REPEATER UNIT
19B801507P2**



Ericsson GE Mobile Communications Inc.
Mountain View Road • Lynchburg, Virginia 24502

Printed in U.S.A.

TABLE OF CONTENTS

SPECIFICATIONS 1
 DESCRIPTION 1
 OPERATION 2
 CIRCUIT ANALYSIS 2
 CHARGER BOARD 2
 DISPLAY REP 3
 INSTALLATION 3
 MAINTENANCE 3
 DISASSEMBLY PROCEDURES 3
 ADJUSTMENT PROCEDURES 4
 TROUBLESHOOTING PROCEDURES 4
 TEST ADAPTOR 5

LIST OF TABLES

TABLE 1 - QUICK CHECKS 4
 TABLE 2 - EQUIPMENT STATUS 4
 TABLE 3 - VOLTAGE READINGS 4

SPECIFICATIONS*

INPUT POWER		11.1 TO 16.5 Volts
DC, negative ground		
CURRENT DRAIN		1.7 A maximum
INPUT CURRENTS		
Standby	1 mA maximum	
Radio Squelched, Trickle Charge		100 mA maximum
Radio Squelched, Rapid Charge		1700 mA maximum
CHARGE TIME		
Standard High Capacity		3 Hours
Extra High Capacity		4 Hours
CHARGE CAPACITY AND TIME VS TEMPERATURE (Standard High Capacity)		
<u>Temperature</u>	<u>Time</u>	<u>Capacity</u>
+5°C (+41°F)	3.3 Hours	100%
+25°C (+77°F)	3.0 Hours	100%
+45°C (+113°F)	2.7 Hours	70%
INDICATORS		
Radio Engaged		Red
Charge		Red
Repeater ON		Yellow
DIMENSIONS.(H x W x D)		22.6 x 15 x 7 cm (8.9 x 5.9 x 2.7 ins.)
WEIGHT		1.4 kG (3.1 lb)

* These specifications are intended primarily for the use of the service technician.

DESCRIPTION

General Electric Vehicular Charger/Repeater units provide the charging facility for the portable radio unit and the Vehicular Repeater System enable/disable function. The portable radio unit battery pack will be charged as long as the radio is inserted into the charging compartment. The Vehicular Repeater System is automatically disabled whenever the portable radio unit is inserted into the charging compartment. It will recharge either the standard high, or extra high capacity nickel-cadmium batteries.

The charging contacts are automatically connected when the radio is inserted into the charger. Radio detect switch S1, located in the battery compartment, applies power to the charging circuit when the radio is inserted. A second switch senses the size of the battery pack and adjusts the charging rate accordingly.

Heat sensors constantly monitor the temperature of both the battery pack and the charging insert. When a cold battery pack is inserted into the charging insert, the charger will wait until the battery pack has warmed up to within about 10°C of ambient. The charger will then, automatically, apply the high charge rate. When the battery pack overcharges enough to heat the cells 10°C above ambient, the charger will switch from fast charge to trickle charge.

The charger also has a memory that is set when the charger switches from the high charging rate to the trickle charge rate and is reset when the battery pack is removed from the charging insert. If a hot battery is in the charging insert and the memory has not been reset, the charger will remain at the trickle charge rate. If the memory has been reset the charger will wait until the battery pack has cooled before automatically switching to fast charge. If a fully charged battery pack is removed from the charging insert and then reinserted, it will charge for about 1/2 hour until the battery pack reheats.

A voltage cut-off circuit has also been incorporated to prevent overcharging and "gassing" of the battery pack. Battery voltage is constantly monitored and, if the battery pack charge terminal voltage exceeds 9.5 volts, high rate charge is terminated and the LED READY light is turned on.

If the radio is on when it is in the charger, it is powered from the radio battery while it is being charged. If the radio is OFF while it is in the charger, it is inoperative; the battery is charged if either condition exists.

CONTROLS AND INDICATORS

Four switches and four indicators provide control and status information for the Vehicular Charger. Refer to Figure 1 for location of controls and indicators.

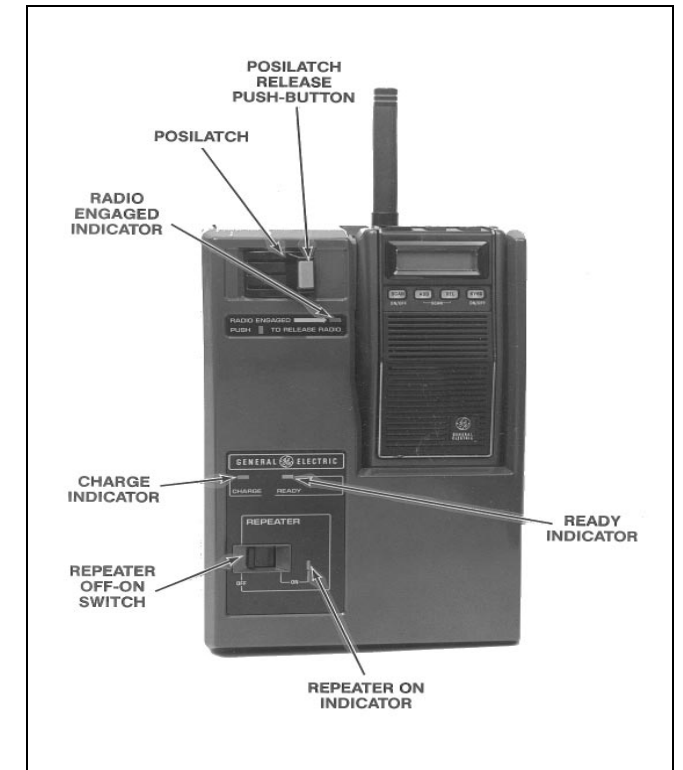

Figure 1 - Vehicular Charger

RADIO ENGAGED (RED)	Lights when the radio is inserted properly into the charger and the radio is latched.
CHARGE (red)	Indicates the battery is being charged.
READY (GREEN)	Indicates the battery is fully charged. The charger will automatically switch from a rapid charge rate to a trickle charge rate.
REPEATER ON-OFF (yellow)	Indicates the repeater is on.
S1 Radio Detect	Closes when the radio is inserted into the charger. Applies battery voltage to Charger Control circuit and Repeater Display board.
S2 Battery Set	Resets the power off and memory circuit.

S3 Radio Engaged	Closes when radio is properly inserted into charging insert and applies power to DS1, RADIO ENGAGED indicator.
S1 Repeater OFF-ON	ON: Enables Vehicular Repeater function if radio is not inserted into charging compartment. OFF: Vehicular Repeater System is disabled.

OPERATION

Temperature characteristics of nickel-cadmium batteries, prevent a full charge at temperature extremes. For maximum charge, recharge the battery pack at ambient room temperature or between 65° and 85°F.

WARNING

The General Electric Vehicular Charger is designed to recharge the GE standard high capacity battery pack and the extra high capacity battery pack. Attempting to recharge any other battery pack or batteries may result in damage to equipment, leakage, or explosion.

CHARGER/REPEATER OPERATION

NOTE

When the portable radio unit is placed in the charging insert, set the REPEATER OFF-ON switch to ON so the Vehicular Repeater System will be enabled automatically when the portable radio is removed from the charger.

The following procedures describe the recharging of the portable radio battery pack and the operation of the Vehicular Repeater System.

1. The power switch on the radio battery pack may be in the ON or OFF position.

2. Insert radio unit into charging compartment with its speaker facing forward (see Figure 2.).
3. Slide the **POSILATCH™** toward the portable radio unit until you feel it engage and the red RADIO ENGAGED indicator lights.
4. Place the REPEATER ON OFF switch to the ON position. The red repeater ON indicator will not light until the portable radio is removed from the charging compartment.

NOTE

The Vehicular Repeater System will be disabled as long as the portable radio unit is in the charging compartment or the REPEATER OFF-ON switch is in the OFF position.

5. The red CHARGE indicator will light and remain lit until the portable radio unit is removed or until the vehicular repeater/charger unit circuits sense that the battery pack has reached total charge capacity. At this time the green READY indicator will also light, indicating that the charger has switched to the trickle charge rate.
6. To remove the portable radio from the charging compartment, depress the blue push-button release on the POSILATCH and slide the latch completely away from the portable radio unit. The red RADIO ENGAGED indicator will turn off and the portable radio unit can be removed from the charging compartment (see Figure 2).

CAUTION

DO NOT use the antenna to remove the portable radio from the charging compartment.

7. Removing the portable radio unit will automatically enable the Vehicular Repeater System and the red REPEATER ON indicator will light.

NOTE

The REPEATER OFF-ON switch must be in the ON position for the Vehicular Repeater System to function.



Figure 2 - Inserting and Removing Portable Radio Unit

CIRCUIT ANALYSIS

The Vehicular Charger is comprised of a Charger board, LED board, Display Repeater board, and a UDC board.

CHARGER BOARD

The Charger board contains the charging circuit, with voltage and temperature cut-off circuits.

CHARGING CIRCUIT

When power is first applied to the charger, the voltage at pin 5 of Comparator A7 is higher than at pin 6 of A7 due to the charging time of C18. The higher voltage causes the output at pin 7 of A7 to go high, keeping A13 turned off. This allows the battery to start charging. A block diagram of the Vehicular Charger is shown in Figure 3.

Charging current flows through series connected resistors R21 and R22 to regulator transistor Q3. The output of Q3 is connected to the positive charging contact of the battery. Test Point TP2 provides a convenient

place to monitor the positive battery contact. A portion of the charging current is routed through resistor R24 and transistor Q2 to turn on CHARGE LED DS3 on the LED board and to provide a trickle charge when Q2 turns off. The series connected charge circuit determines the high charge rate and is controlled by the temperature controlled cut-off circuit.

CHARGER CONTROL CIRCUIT

The Charger Control circuit consists of a temperature controlled cut-off circuit and battery charged memory circuit. The temperature controlled cut-off circuit consists of integrated circuit A13, a bridge circuit comprised of R29, R30, R33, thermistors RT1 and RT (BATT), and associated circuitry. Temperature cut-off IC A13 monitors the temperature of the charging insert through thermistor RT1 and the temperature of the battery pack through internal thermistor RT (BATT). It also controls transistors Q3 and Q4, turns the "READY" indicator on when the battery pack is fully charged, and provides memory to prevent the same battery pack from being recharged at the high rate.

Thermistors RT1 and RT (BATT) are connected with R29, R30, and R33 to form a bridge circuit (see Figure 4). The output of the bridge circuit is connected to terminals 13 and 14 of A13.

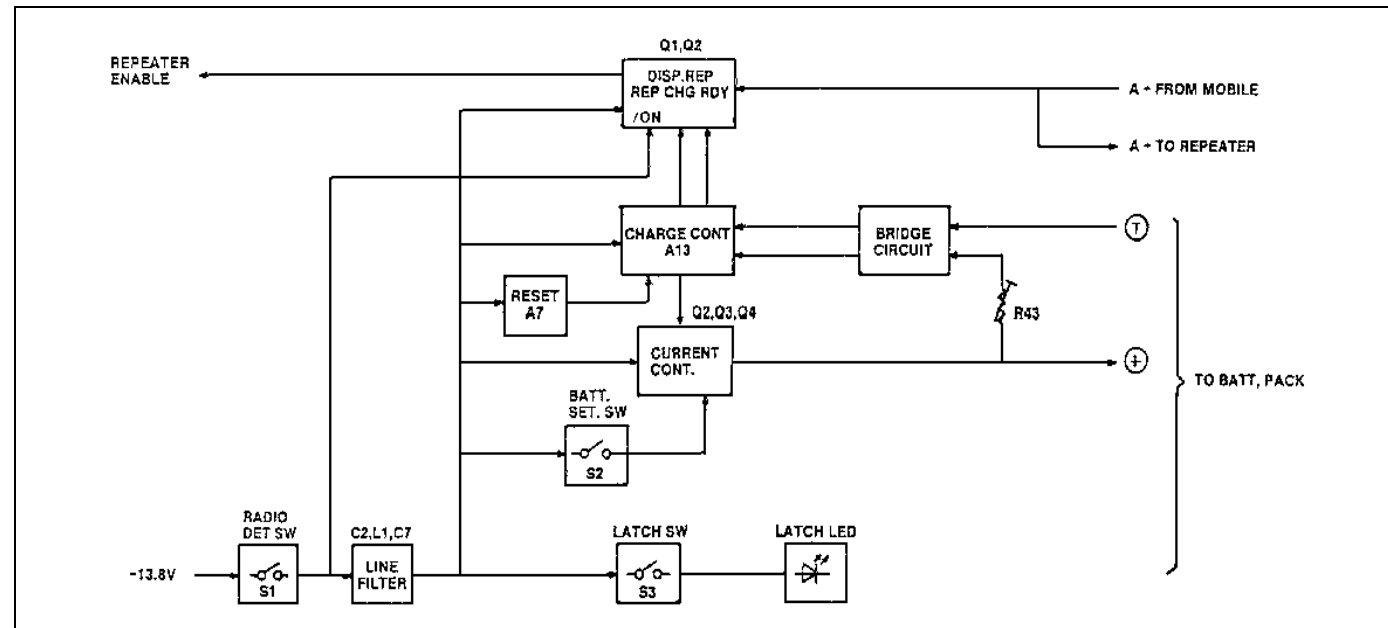

Figure 3 - Vehicular Repeater Charger

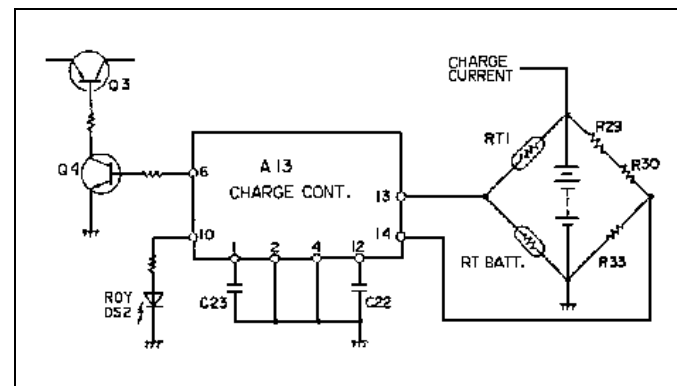

Figure 4 - Simplified Temperature Cut-Off Circuit

When the battery pack temperature is more than 10°C (18°F.) below ambient, thermistor RT (BATT) exhibits a high resistance, causing the voltage on A13-13 to be larger than the voltage on A13-14. (The same thing would occur if there were no battery pack present). There is no output from A13-6 or A13-10. Transistor Q3 and LED READY indicator DS2 remain off. The battery pack charges at the trickle charge rate, determined by series resistance R24, until the temperature is less than 10°C below ambient. At less than 10°C below ambient, the voltage at A13-13 is still larger than the voltage on A13-14, the output at A13-6 goes high causing transistor Q4 to conduct, turning Q3 on and beginning the high-rate charge.

As the battery pack temperature increases to 10°C above ambient at end of charge, the voltages at A13-13 and A13-14

become equal, indicating the bridge circuit is balanced and the battery pack is fully charged. A14-6 goes low, causing Q4 to stop conducting. Q3 cuts off and the charge rate switches from the high charge rate to the trickle charge rate. The equal voltages on A13-13 and A13-14 cause the output at A13-10 to go high, turning READY indicator DS2 on.

A memory circuit internal to A13 is set so that the same battery can not be recharged at the high rate unless it first has been discharged or removed from the charger. When the battery pack is removed from the charging insert, RT (BATT) is removed from the bridge circuit causing the bridge to again be unbalanced. A13 senses the bridge in an unbalanced state, the voltage A13-13 being larger than the voltage on A13-14, and resets the charger memory. Microswitch S1 (RADIO DETECT) will also remove power from the charger circuits, causing the memory to reset.

VOLTAGE CONTROLLED CUT-OFF

The voltage controlled cut-off circuit monitors the battery voltage and cuts off regulator Q3 when the battery charging terminal voltage exceeds 9.5 Vdc. It is comprised of Comparator A7, Charge Control IC A13, and associated circuitry.

A reference voltage derived from voltage divider R37, R38, R41, and zener diode CR12 is applied to pin 2 of Comparator A7. Resistor R43 is adjusted for a battery charging terminal voltage of 9.5 Vdc. A voltage equal to the reference voltage on pin 2 is applied to pin 3 of A7. This causes A7-1 to

go high, applying a lesser voltage to A13-14 than is applied to A13-13. This causes A13 to turn Q3 off and turn READY indicator DS2 on. **NOTE:** During charging there is one diode drop between the (+) charge terminal and the (+) terminal of the battery pack.

POWER INPUT CIRCUIT

When a radio is present in the Vehicular Repeater Charger, 13.8 Vdc from the vehicle battery is supplied to the Charger board through a 5 ampere fuse and J1-6. This voltage is then passed through normally open (no) contacts of S1 and terminated at J7-4 on the Charger board. Diode CR1 provides reverse voltage polarity protection. The charger circuit is powered through a noise filter consisting of C1, C2, L1, and C7.

When the radio is removed from the charging insert, radio detect microswitch S1 closes and applies 13.8 Vdc to the base of repeater enable transistor Q2 on the Display Repeater board. If Q2 collector voltage (from J2-1) is present, and if the REPEATER OFF-ON switch is in the ON position, then the REPEATER ENABLE line (J1-3) goes high.

DISPLAY REP CA2

The Display board provides the current status information for the Vehicular Repeater Charger and radio. It contains the READY, CHARGE, and REPEATER ON indicators and associated repeater control circuitry. The cathodes of DS2 and DS3 are at ground and turn on when a positive voltage from the charge control circuit is applied.

READY indicator DS2 is controlled by A13 and turned on when the battery is fully charged as indicated by a positive voltage being applied from A13-10 through J7-7 to the anode of DS2, turning DS2 on.

CHARGE indicator DS3 is controlled by BATT SET 2 transistor Q2. When the battery is being charged Q2 is turned on, applying 13.8 Vdc from the battery input at J1-6 through J7-6 to the anode of DS3, turning DS3 on.

REPEATER ON indicator DS4 is controlled by the REPEATER OFF-ON switch. A+ from the mobile radio is applied to the anode of DS4 through J2-1. A+ from the battery is applied to the base of Q2 through J1-6, S1, and J7-4. When the REPEATER OFF-ON switch S1 is turned

ON, A- is applied to the emitter of Q2, turning Q2 and DS4 on.

LED BOARD CA1

LED board CA1 contains the RADIO ENGAGED indicator. When the POSILATCH switch is moved to the latched position, battery voltage is applied to the anode of DS1 through J1-7 and S3, turning the RADIO ENGAGED indicator on.

INSTALLATION

Install the Vehicular Charger in a convenient place where it will not interfere with the safe operation of the vehicle. Refer to the Installation manual for specific installation instructions.

MAINTENANCE

The Maintenance section contains Disassembly instructions, Troubleshooting Procedures, and Adjustment Procedures. A Test Adaptor may be constructed to facilitate servicing the Vehicular Charger. The Test Adaptor is used to simulate actual battery pack conditions and to determine if the charger is working properly. Simulations include cold battery pack, battery pack at room temperature, and hot battery pack. Pertinent information is provided in the last section of this manual.

DISASSEMBLY PROCEDURES

To remove the Top Cover:

- Remove the six Phillips head screws on the back of the housing. (Three at the top edge, two at the bottom corners, and one in the center).

To Remove The Charge Board:

- Remove the top cover.
- Remove the four screws from the Charge board and one screw from the heatsink for Q3.

To Remove The Repeater Display Board:

- Remove the top cover.
- Remove the four screws securing the Display board to the chassis.

ADJUSTMENT PROCEDURES

various modes of operation are provided as a troubleshooting aid.

Test Equipment Required

1. Test Adaptor (See Figure 5)
2. Digital Voltmeter

Test Equipment Required

- Multimeter
Test Adaptor

Voltage Cutoff

1. Connect the Test Adaptor to TB-1.
2. Set switch S1 on Test Adaptor to position 2.
3. Set S1 on Charge Board to "ON" to apply power to the charging circuit.
4. Set R43 on Charge Board fully counter clockwise (CCW).
5. Connect the Digital Voltmeter to TP2, and set its voltage at $+9.5\text{ V} \pm 0.05\text{ V}$ by adjusting trimmer R4 on the Test Adaptor.
6. Verify that voltage on A13-6 exceeds +10 volts.
7. Slowly adjust R43 clockwise until the RDY indicator just turns on.

Procedures

1. Connect the Test Adaptor to TB1 on the Charge Board.
2. Set S1 on the Test Adaptor to position 2.
3. Set S1 on the Charger Board to ON to power up the charging circuit.
4. Adjust R4 on the Test Adaptor for +8.5 Vdc as measured at TP2 on the Charge Board.
5. Sets S1 on the Charge Board to OFF. Set S1 on the Test Adaptor to position 1.
6. Set S1 on the Charge board to ON. Refer to Tables 1 and 2 and monitor the reference points listed. Problem areas are identified by an indication other than that listed in the tables.
7. Set S1 on the Charger Board to the OFF position. Set S1 on the Test Adaptor to position 3.
8. Set S1 on the Charge Board to the ON position and then back to the OFF position.
9. Disconnect the Test adaptor from TB1.
10. Set S1 on the Charge Board to the ON position. This completes the operational checks of the charger.

TROUBLESHOOTING PROCEDURES

A Troubleshooting Procedure is provided to assist the service technician to rapidly isolate a fault in the equipment. A table of Quick Checks and reference tables containing typical voltage readings and pin status for

Table 1 - Quick Checks

PROBLEM	ACTION
CHARGE Led does not light.	Check input fuse, Q2, & C19
READY light fails to come on. Battery pack is good. Charging time has elapsed.	Check Q3, Q4, & DS4
A13-10 always high. Logic fails to reset.	Check C19
A13-6 always low. No fast reset	Check C22 charge.
A13-5 always low.	Check C23
Fast charge circuit does not function	Check CR9, Q3, & Q4 for open.

Table 2 - Equipment Status

REF. STEP	SW POS	A13 6	PIN 5	NO 10	CHRG LED	READY LED	REMARKS
6	1 2 3	Low* High Low	Low Low High	Low Low High	On On On	Off Off On	Cold Battery Normal Battery Charging Charged Battery
7	3	Low	Low	Low	On	Off	Hot Battery
8	N/A	Low	Low	Low	Off	Off	No Battery
*LOW- Pin Voltage less than 1.0 Volt HIGH- Pin voltage greater than 3.0 Volts							

Table 3 - Typical Voltage Readings (all voltages are + dc.)

Power Supply Voltage: +13.8 Vdc.				
CHECK POINT	S1 : ON W/O BATTERY	RAPID CHARGING STANDARD HI CAPACITY		TRICKLE CHARGING STANDARD/HI CAPACITY
TP2	8.35	8.50	8.57	8.37
TP5	-	4.15	4.20	4.8
TP6	4.74	4.74	4.74	4.74
TB1-4 (T)	5.60	5.47	5.54	3.53
Q3-E	13.79	12.02	11.981	3.79
Q4-C	13.37	0.03	0.03	13.36
A13-14	4.04	3.58	3.68	8.08
A13-12	5.13	11.09	11.05	5.21

TEST ADAPTOR

A Test Adaptor may be constructed to facilitate servicing the Vehicular Charger. The Test Adaptor is used to simulate

actual battery pack conditions and to determine if the charger is working properly. Simulations include cold battery pack, battery pack at room temperature, and a hot battery pack. A Schematic Diagram and Parts List are shown below.

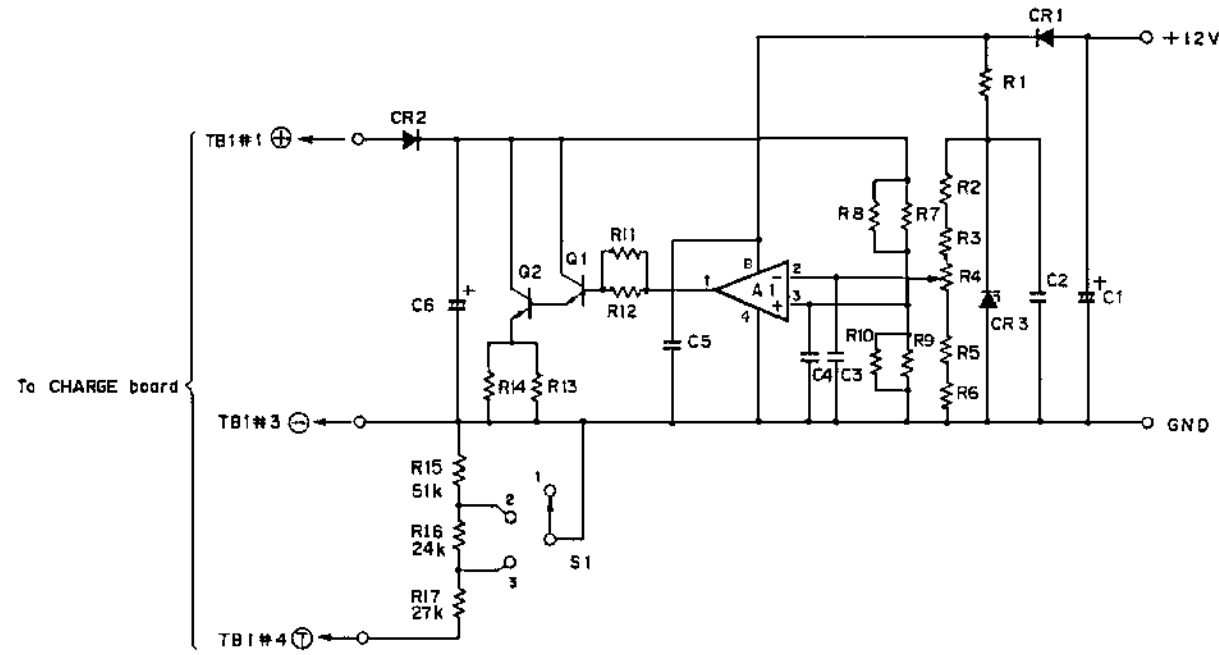

NOTE 1. R15, R16 and R17 are 1%.

**LBI-31911
TEST ADAPTOR**

SYMBOL	PART NUMBER	DESCRIPTION
--- INTEGRATED CIRCUITS ---		
A1	K19/2AAB0005141	OP-AMP HA17904GS
----- CAPACITORS -----		
C1	K19/2CBB035045	A1. Electrolytic: 100 µF, 25V
C2 thru C5	K19/2CAJ031592	Ceramic: RPE122F104Z50, 0.01 µF
C6	K19/	A1. Electrolytic: 1000 µF, 35V
----- DIODES -----		
CR1 and CR2	K19/2QBC008319	V06C
CR3	K19/2QBB005845	RD6.8EB
----- TRANSISTORS -----		
Q1	K19/	2SC1815
Q2	K19/	2SD235
----- RESISTORS -----		
R1	K19/2RAA002026	Carbon fixed: RD25S, 680 ohms ±5%
R2	K19/2RAA002059	Carbon fixed: RD25S, 1 K ohms ±5%
R3	K19/2RAA002299	Carbon fixed: RD25S, 15 K ohms ±5%
R4	K19/2RFA045016	Variable: K161108TE, 10 K ohms ±5%
R5 and R6	K19/2RAA002299	Carbon fixed: RD25S, 15 K ohms ±5%
R7	K19/2RAA002448	Carbon fixed: RD25S, 100 K ohms ±5%
R8	K19/2RAA002299	Carbon fixed: RD25S, 15 K ohms ±5%
R9	K19/2RAA002448	Carbon fixed: RD25S, 100 K ohms ±5%
R10	K19/2RAA002299	Carbon fixed: RD25S, 15 K ohms ±5%
R11	K19/2RAA002448	Carbon fixed: RD25S, 100 K ohms ±5%
R12	K19/2RAA002299	Carbon fixed: RD25S, 15 K ohms ±5%
R13 and R14	K19/2RBA001802	Metal fixed: RSF2B 3R3, 3.3 ohms ±5%
R15	K19/2RBD004043	Metal fixed: RNF1/4C3, 51 K ohms ±1%
R16	K19/	Metal fixed: RNF1/4C3, 24 K ohms ±1%
R17	K19/	Metal fixed: RNF1/4C3, 27 K ohms ±1%
----- SWITCHES -----		
S1	K19/	SRF113

**VEHICULAR CHARGER/REPEATER UNIT
19B801507P2
ISSUE 1**

SYMBOL	PART NUMBER	DESCRIPTION
--- INTEGRATED CIRCUITS ---		
A7	K19/2AAB0005141	OP-AMP HA17004GS
A13	K192AAE035061	HIC H8D2036
----- CAPACITORS -----		
C1	K19/2CAK0005503	Ceramic chip: 0.1 µF +80/-20%, 50V
C2	K19/2CBB043197	A1. Electrolytic: 220 µF, 25V
C3	K19/2CAK0005503	Ceramic chip: 0.1 µF +80/-20%, 50V
C4	K19/2CAK0005292	Ceramic chip: 470 pF ±5%, 50V
C5	K19/2CCC024137	Tantalum: 4.7 µF, 16V
C6	K19/2CBB042215	A1. Electrolytic: 220 µF, 16V
C7	K19/2CBB043205	A1. Electrolytic: 470 µF, 25V
C18	K19/2CCC032072	Tantalum: 4.7 µF, 25V
C19	K19/2CAJ031527	Ceramic: RPE113F474Z50, 0.47 µF
C20	K19/	A1. Electrolytic: 2.2 µF, 50V
C21	K19/2CDC001018	Plastic film: ECQ-V1H104JZ, 0.1 µF
C22	K19/	Tantalum: 0.47 µF, 50V
C23	K19/2CBB087228	A1. Electrolytic: 22 µF, 16V
C32	K19/2CAK0005838	Ceramic chip: 1000 pF ±10%, 50V (3.2x1.6)
C33	K19/2CAK0005503	Ceramic chip: 0.1 µF +80/-20%, 50V
C37	K19/2CAK0005503	Ceramic chip: 0.1 µF +80/-20%, 50V
C39	K19/2CAK0005503	Ceramic chip: 0.1 µF +80/-20%, 50V
C52 and C53	K19/2CAK0005383	Ceramic chip: 1000 pF ±10%, 50V (3.2x1.6)
C55 thru C60	K19/2CAK013127	Ceramic chip: 1000 pF ±10%, 50V (2x1.2)
C101 thru C104	K19/2CAK013127	Ceramic chip: 1000 pF ±10%, 50V (2x1.2)
C105 and C106	K19/2CAK0005474	Ceramic chip: 100 pF ±10%, 50V (2x1.2)
C107 thru C116	K19/2CAK013127	Ceramic chip: 1000 pF ±10%, 50V (2x1.2)
C117	K19/2CAK0005474	Ceramic chip: 100 pF ±10%, 50V (2x1.2)
C119 and C120	K19/2CAK013127	Ceramic chip: 1000 pF ±10%, 50V (2x1.2)
C121	K19/2CAK0005474	Ceramic chip: 100 pF ±10%, 50V (2x1.2)
C122 thru C132	K19/2CAK013127	Ceramic chip: 1000 pF ±10%, 50V (2x1.2)
C133 thru C135	K19/2CAK0005383	Ceramic chip: 1000 pF ±10%, 50V (3.2x1.6)
C136 and C137	K19/2CAK013127	Ceramic chip: 1000 pF ±10%, 50V (2x1.2)
C140 thru	K19/2CAK0005383	Ceramic chip: 1000 pF ±10%, 50V (3.2x1.6)

* COMPONENTS, ADDED, DELETED OR CHANGED BY PRODUCTION CHANGES

* COMPONENTS, ADDED, DELETED OR CHANGED BY PRODUCTION CHANGES

SYMBOL	PART NUMBER	DESCRIPTION
		----- CABLE ASSEMBLY -----
CA1	K19/2WHE010461	LL-S-2S-S2C2-S L=200mm A4WX01801
		----- DIODES -----
CR1	K19/2QBC008129	S11B
CR4 thru CR11	K19/2QBE003029	1S2835-T1
CR12	K19/2QBB001737	HZ-7B-1
CR13	K19/2QBE003029	1D2835-T1
CR14	K19/2QBD011429	ERZ-M10DK220
		----- CONNECTORS -----
J1	K19/2PDA020172	5278-05A
J2	K19/2PDA020123	5274-06A
J3 and J4	K19/2PDA029058	5274-04A
J5	K19/2PDA029074	LL-S-3P-S2T2-EF
J6	K19/2PDA026374	LL-S-7P-S2T2-EF
J7	K19/2PDA012740	LL-S-11P-S2T2-EF
J8 and J9	K19/2PDA029058	LL-S-2P-S2T2-EF
		----- INDUCTORS -----
L1	K19/2LAA024083	A4ZX00299B
		----- TRANSISTORS -----
Q2	K19/2QAD001018	2SA1052MCTL
Q3	K19/2QAB008239	2SB553Y
Q4	K19/2QAD001158	2SC2618RCTL
		----- RESISTORS -----
R13	K19/2RGC001155	Square chip: 1 K ohms ±5%
R21	K19/2RBA001190	Metal fixed: RSF1B, 4.7 ohms ±5%
R22	K19/2RBA004626	Metal fixed: RSF1/2B, 8.2 ohms ±5%
R23	K19/2RGC001155	Square chip: 1 K ohms ±5%
R24	K19/2RBD003045	Metal fixed: RSM2FB51ΩJ, 51 ohms ±5%
R25	K19/2RBA001455	Metal fixed: RSF1B, 560 ohms ±5%
R26	K19/2RGC001213	Square chip: 10 K ohms ±5%
R27	K19/2RGC001205	Square chip: 6.8 K ohms ±5%
R28	K19/2RGC001023	Square chip: 10 K ohms ±5%
R29	K19/2BDC004035	Metal fixed: RNF1/4C3, 100 Kohms ±1%
R30	K19/2BDC004043	Metal fixed: RNF1/4C3, 51 Kohms ±1%
R31	K19/2RGC001197	Square chip: 4.7 K ohms ±5%
R32	K19/2RGC001288	Square chip: 68 K ohms ±5%
R33	K19/2RBD	Metal fixed: RNF1/4C3, 120 Kohms ±1%
R34 and R35	K19/2RGC001304	Square chip: 100 K ohms ±5%
R36	K19/2RGC001346	Square chip: 470 K ohms ±5%

SYMBOL	PART NUMBER	DESCRIPTION
R38	K19/2RGC001197	Square chip: 4.7 K ohms ±5%
R39 and R40	K19/2RGC001304	Square chip: 100 K ohms ±5%
R41	K19/2RGC001213	Square chip: 10 K ohms ±5%
R42	K19/2RGC001171	Square chip: 2.2 K ohms ±5%
R43	K19/2RFB017043	Variable: RGS6-FAN, 1 K ohms ±5%
R44	K19/2RGC001171	Square chip: 2.2 K ohms ±5%
R45	K19/2RGC001155	Square chip: 1 K ohms ±5%
R54	K19/2RGC001213	Square chip: 10 K ohms ±5%
R62	K19/2RGC001312	Square chip: 150 K ohms ±5%
R74	K19/2RDA073021	Wire wound: M-3, 0.33 ohms ±5%
R77	K19/2RGC001320	Square chip: 220 Kohms ±5%
		----- THERMISTORS -----
RT1	K19/2QBD016121	NTCDS40204AG503GC, 50 Kohms, A4WX01483
		----- SWITCHES -----
S1 thru S3	K19/2KKA001718	SS-5GL3004
		----- TERMINALS -----
TB1	K19/	Terminal
		----- TEST POINTS -----
TP1 thru TP6	K19/2PYD002718	75404-001
		----- MISCELLANEOUS -----
Z1	K19/2QYY013059	Silicon rubber 30F-TO-3PF. (Used for Q1).
Z3	K19/2QYY013034	Silicon rubber 30F-TO-220. (Used for Q3).
Z4	K19/2QYY002094	Isolated washer YC40B. (Used for Q3).
		DISPLAY REPEATER
		----- CAPACITORS -----
C2 and C3	K19/2CAK013127	Ceramic chip: 1000 pF ±10%, 50V
C5 thru C10	K19/2CAK013127	Ceramic chip: 1000 pF ±10%, 50V
		----- CABLE ASSEMBLY -----
CA1	K19/2WHE010404	LL-T-11P-S2C2-W LL-S-11S-S2C2-S
CA2	K19/2WHE010396	LL-T-3P-S2C2-W L=120mm A4WX01776
		----- DIODES -----
DS2	K19/2HAC010127	LED LD-201MG
DS3	K19/2HAC001013	LED LD-201VR
DS4	K19/2HAC010143	LED LD-201YY
		----- TRANSISTORS -----
Q1 and	K19/2QAD001158	2SC2618RCTL

SYMBOL	PART NUMBER	DESCRIPTION
		----- RESISTORS -----
R2 thru R4	K19/2RAA002059	Carbon fixed: RD25S, 1 K ohms ±5%
R5	K19/2RAA002265	Carbon fixed: RD25S, 1 K ohms ±5%
R6	K19/2RAA002059	Carbon fixed: RD25S, 1 K ohms ±5%
R7	K19/2RAA002265	Carbon fixed: RD25S, 10 K ohms ±5%
		----- SWITCHES -----
S1	K19/2KGC002127	8M1011 w/8Z0011
		LED BOARD
		----- CAPACITORS -----
C1	K19/2CAK013127	Ceramic chip: 1000 pF ±10%, 50V
		----- CABLE ASSEMBLY -----
CA1	K19/2WHE010412	LL-T-2P-S2C2-W LL-S-2S-S2C2-S
		----- DIODES -----
DS1	K19/2HAC010135	LED LD-201VR
		CHASSIS ACCESSORIES
		----- CABLE ASSEMBLY -----
CA1	K19/2WHE010446	Power cable: A4WX01796-1
		----- MISCELLANEOUS -----
Z11	K19/2PGA004112	Terminal V1.25-5 (Red)
Z12	K19/2PGA002538	Terminal V1.25-6 (Red)
Z13	K19/	Terminal V1.25-8 (Red)
		TEST ADAPTOR
		----- INTEGRATED CIRCUITS -----
A1	K19/2AAB005141	OP-AMP HA17904GS
		----- CAPACITORS -----
C1	K19/2CBB035045	A1. Electrolytic: 100 μF, 25V
C2 thru C5	K19/2CAJ031592	Ceramic: RPE122F104Z50, 0.01 μF
C6	K19/	A1. Electrolytic: 100 μF, 35V
		----- DIODES -----
CR1 and CR2	K19/2QBC008319	V06C
CR3	K19/2QBB005845	RD6.8EB
		----- TRANSISTORS -----
Q1	K19/	2SC1815
Q2	K19/	2SD235
		----- RESISTORS -----
R1	K19/2RAA002026	Carbon fixed: RD25S, 680 ohms ±5%
R2	K19/2RAA002059	Carbon fixed: RD25S, 1 K ohms ±5%
R3	K19/2RAA002299	Carbon fixed: RD25S, 15 K ohms ±5%
R4	K19/2RFA045016	Variable: K161108TE, 10 K ohms ±5%

SYMBOL	PART NUMBER	DESCRIPTION
R5 and R6	K19/2RAA002299	Carbon fixed: RD25S, 15 K ohms ±5%
R7	K19/2RAA002448	Carbon fixed: RD25S, 100 K ohms ±5%
R8	K19/2RAA002299	Carbon fixed: RD25S, 15 K ohms ±5%
R9	K19/2RAA002448	Carbon fixed: RD25S, 100 K ohms ±5%
R10	K19/2RAA002299	Carbon fixed: RD25S, 15 K ohms ±5%
R11	K19/2RAA002448	Carbon fixed: RD25S, 100 K ohms ±5%
R12	K19/2RAA002299	Carbon fixed: RD25S, 15 K ohms ±5%
R13 and R14	K19/2RBA001802	Metal fixed: RSF2B 3R3, 3.3 ohms ±5%
R15	K19/2RBD004043	Metal fixed: RNF1/4C3, 51 K ohms ±1%
R16	K19/	Metal fixed: RNF1/4C3, 24 K ohms ±1%
R17	K19/	Metal fixed: RNF1/4C3, 27 K ohms ±1%
		----- SWITCHES -----
S1	K19/	SRF113

PRODUCTION CHANGES

Changes in the equipment to improve performance or to simplify circuits are identified by a "Revision Letter" which is stamped after the model number of the unit. The revision stamped on the unit includes all previous revisions. Refer to the Parts List for the descriptions of parts affected by these revisions.

REV.A. - Vehicular Charger/Repeater Unit 19B901507P2

To increase trickle charge current. Changed R24
Old Part No. was:
K19/2RBA001331Metal fixed: RSF1B, 120 ohms ±5%

UDC BOARD

COMPONENT SIDE

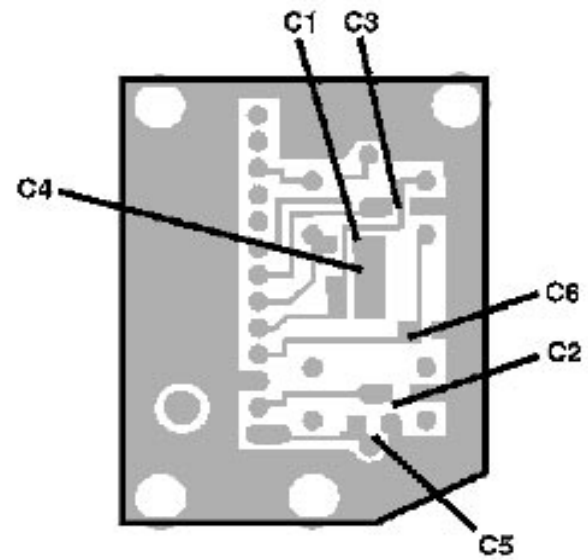

SOLDER SIDE

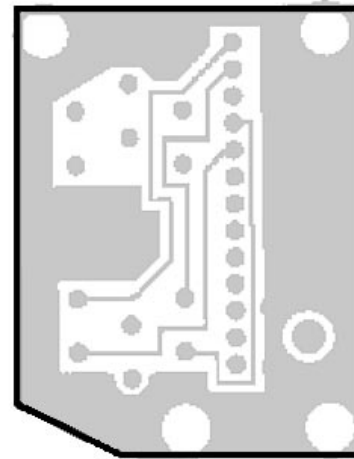

LED BOARD

COMPONENT SIDE

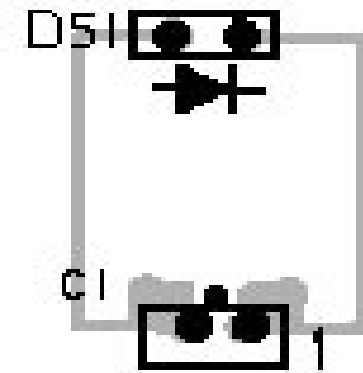

COMPONENT SIDE

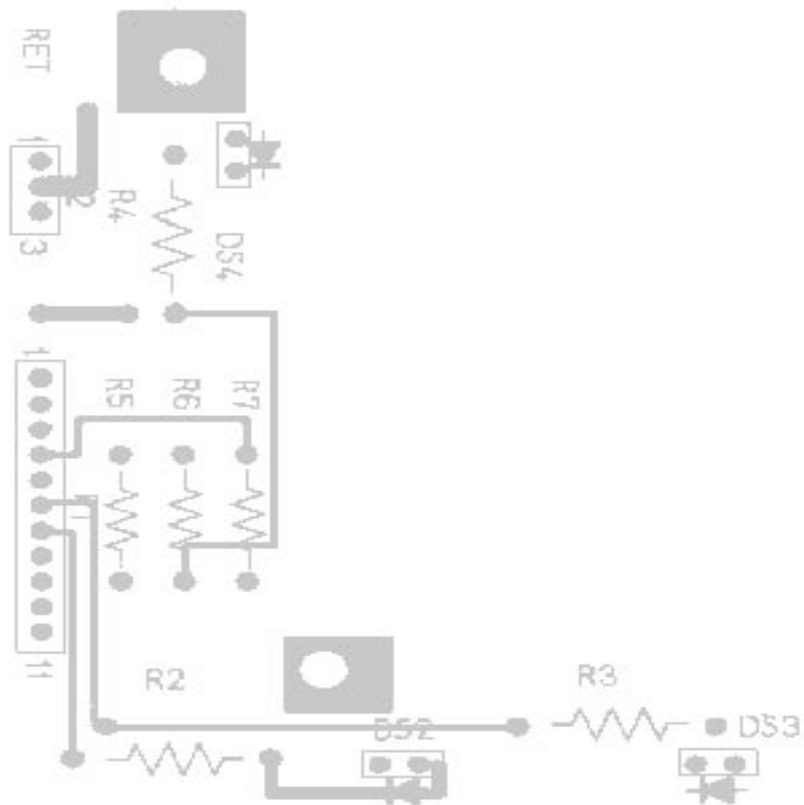

SOLDER SIDE

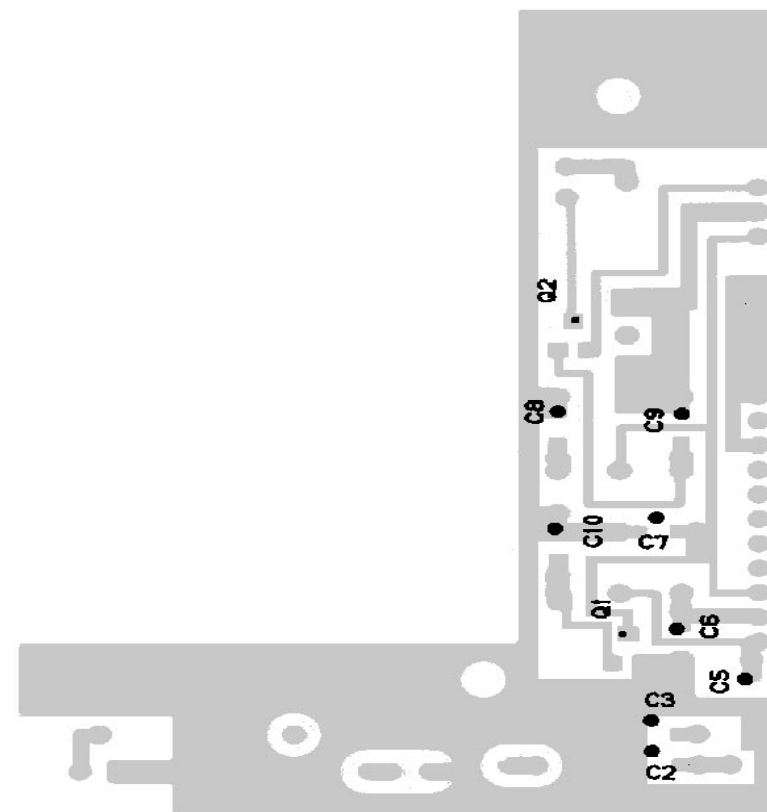

DISPLAY REPEATER P2

COMPONENT SIDE

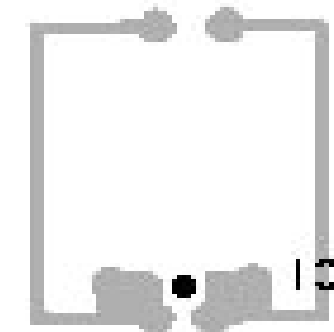

DISPLAY REPEAT BOARD
LED BOARD
UDC BOARD

COMPONENT SIDE

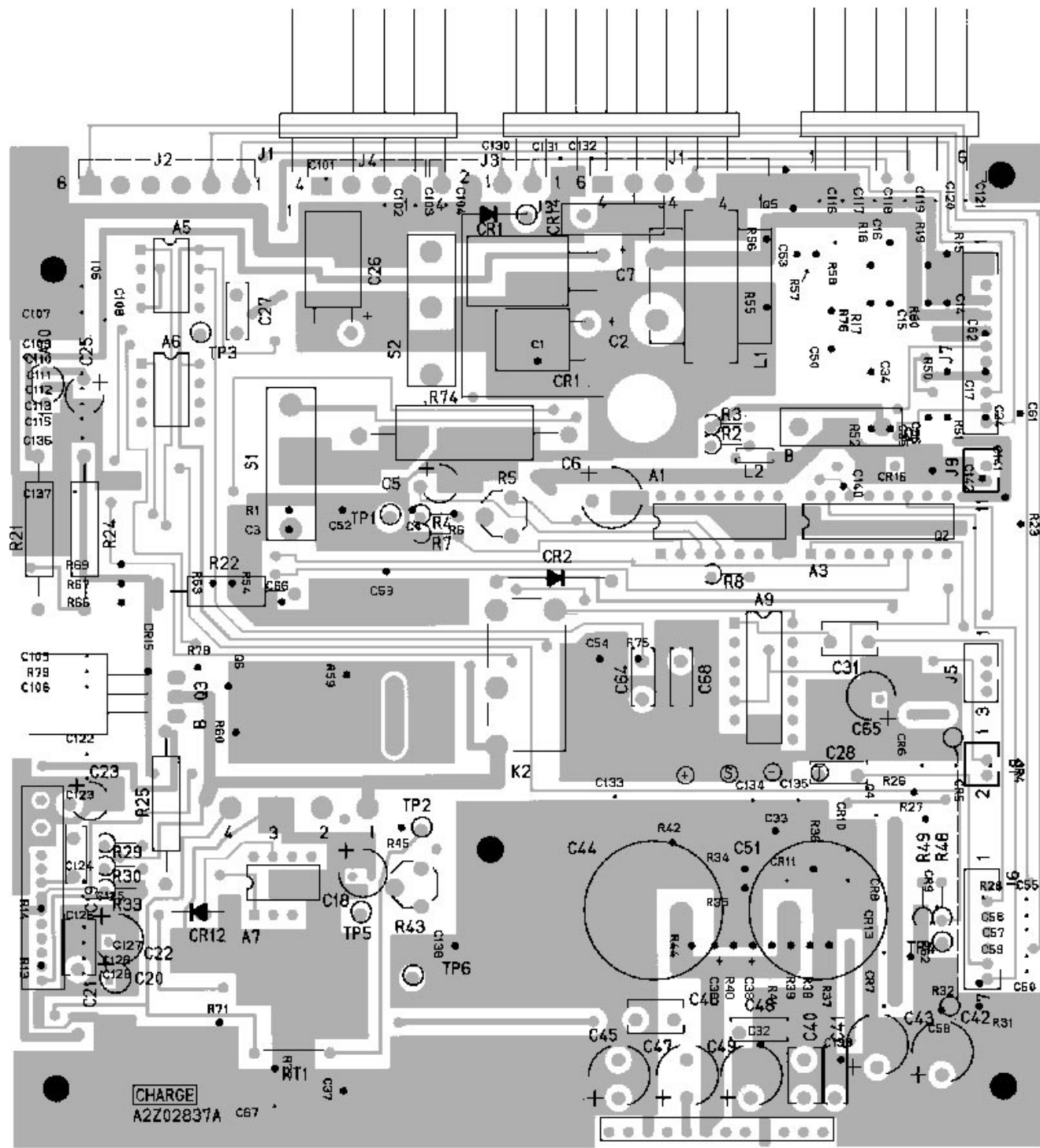

(SA A3Z03063A)
(TA A3Z03063A)

SOLDER SIDE

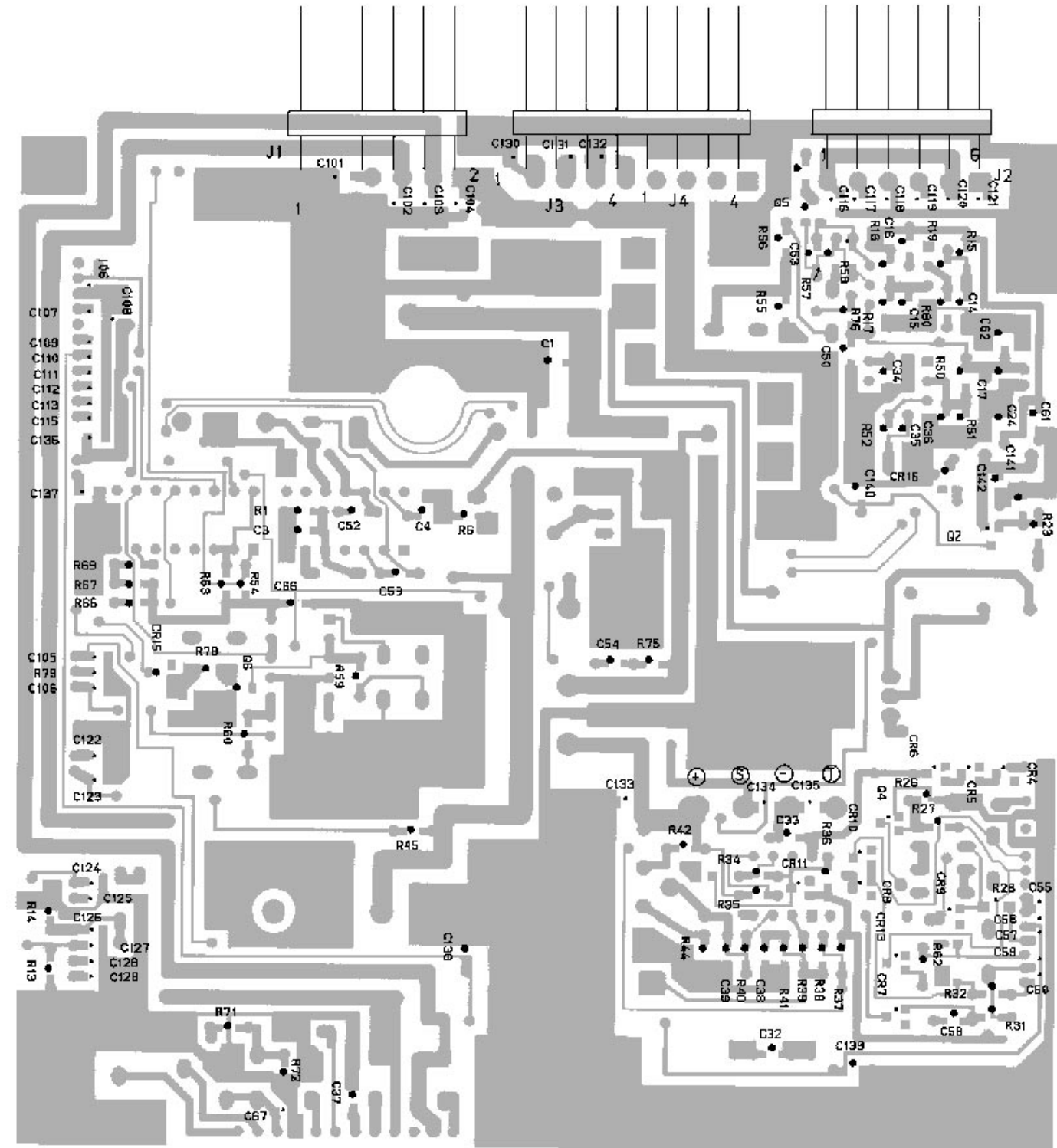

(SB A3Z03063A)
(TB A3Z03063A)

CHARGE BOARD
Issue 1

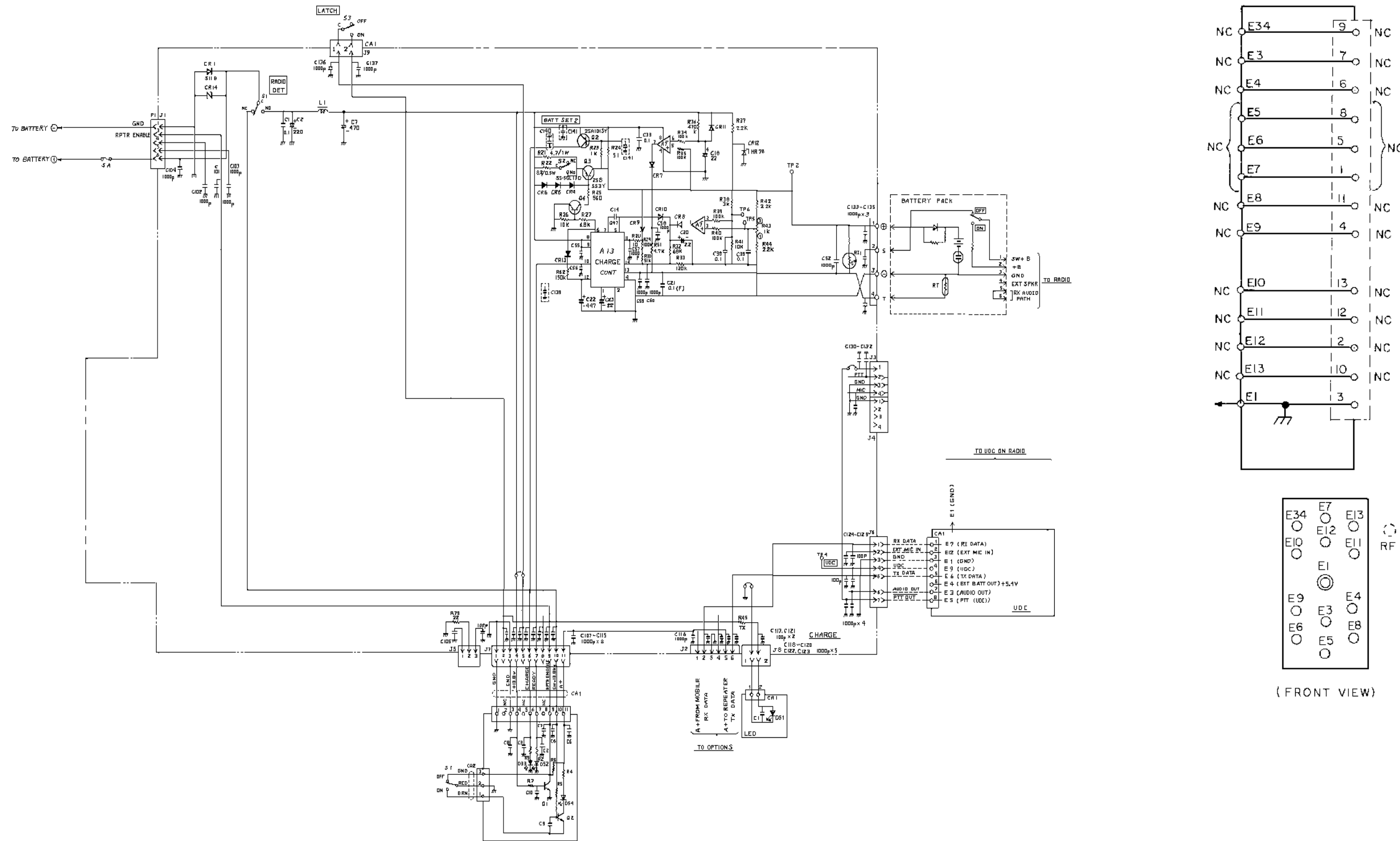

VEHICULAR CHARGER REPEATER
UDC CONNECTOR
Issue 1