

PREPARED BY: D. Grunert	APPROVED BY: (D. Gunert)	DATE: 8/16/02	REV. B	DOCUMENT NO# PS-CA101619	FILE:
----------------------------	-----------------------------	------------------	-----------	-----------------------------	-------

3 SCHEMATIC DIAGRAMS

Part Number: CA101619V1
Revision: A
Name: Standard HHC Interface

Equivalent Remote Interface
 Adapter Jumper Positions:

Shorted positions: A, C, E
 Open positions: B, D, F

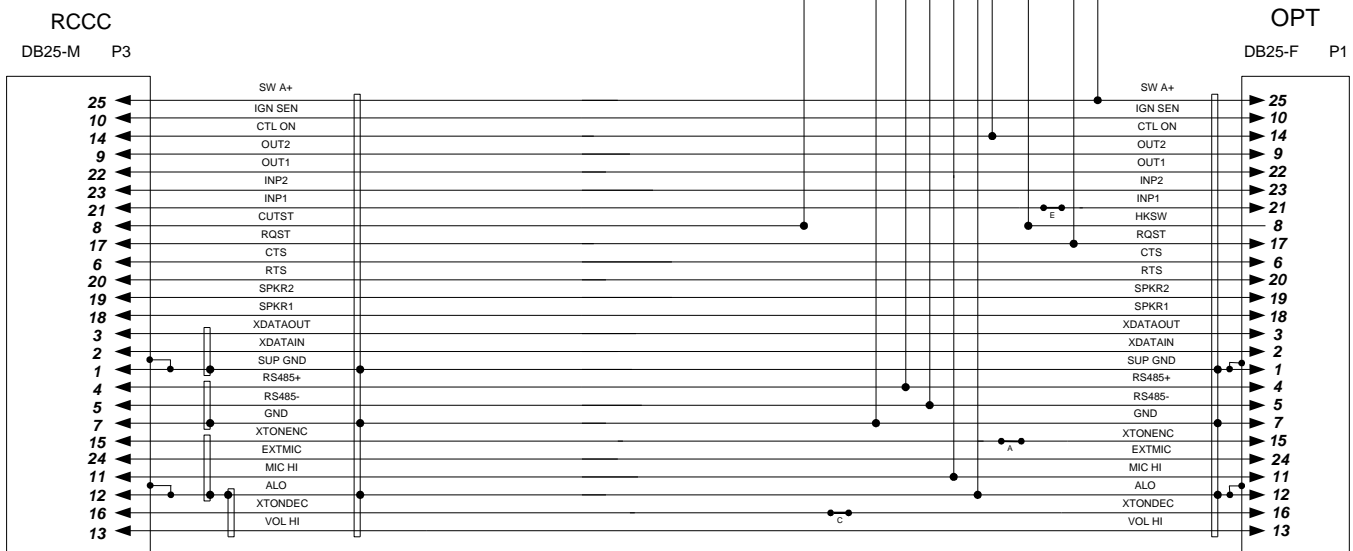
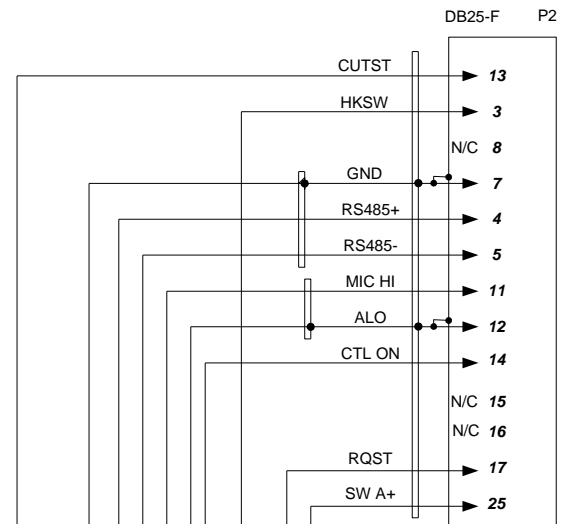

Revision History

- 10/18/01 PA1 - Original Release
- 11/8/01 PA2 - Added Gnds to Connector Housing, Relabeled P2 to show N/C's, clarified cable connections for Remote Interface Adapter Jumper positions.
- 2/5/02 PA3 - Changed P/N from CU101239V100 to CA101619V1. No other changes.
- 8/16/02 A - Released - no changes