

future
The Future of Mobile Radio



Hand Held Controller
CU101239V1

NOTICE!

This manual covers M/A-COM, Inc., products manufactured and sold by M/A-COM, Inc.

NOTICE!

Repairs to this equipment should be made only by an authorized service technician or facility designated by the supplier. Any repairs, alterations or substitutions of recommended parts made by the user to this equipment not approved by the manufacturer could void the user's authority to operate the equipment in addition to the manufacturer's warranty.

This manual is published by **M/A-COM, Inc.**, without any warranty. Improvements and changes to this manual necessitated by typographical errors, inaccuracies of current information, or improvements to programs and/or equipment, may be made by **M/A-COM, Inc.**, at any time and without notice. Such changes will be incorporated into new editions of this manual. No part of this manual may be reproduced or transmitted in any form or by any means, electronic or mechanical, including photocopying and recording, for any purpose, without the express written permission of **M/A-COM, Inc.**

Copyright© 2003 M/A-COM, Inc. All rights reserved.

TABLE OF CONTENTS

	<i>Page</i>
1 SPECIFICATIONS	4
1.1 GENERAL SPECIFICATIONS.....	4
1.2 ENVIRONMENTAL SPECIFICATIONS.....	5
2 IMPORTANT SAFETY INFORMATION	6
2.1 SAFETY SYMBOLS.....	6
2.2 GENERAL WARNINGS AND CAUTIONS.....	6
3 INTRODUCTION	7
4 RELATED DOCUMENTS	8
5 DESCRIPTION	9
6 OPTIONS AND ACCESSORIES	10
7 CIRCUIT DESCRIPTION	11
8 SERVICE	12
8.1 CARE OF EQUIPMENT.....	12
8.2 PROGRAMMING.....	12
8.3 HHC DISASSEMBLY AND REASSEMBLY.....	12
8.3.1 Tools required.....	12
8.3.2 Housing Disassembly and Reassembly.....	12
8.3.3 Replacing Keypad.....	13
8.3.4 Replacing Flex Ribbon Cable #1 (between Back Board and Volume PCB).....	14
8.3.5 Replacing Flex Ribbon Cable #2 (between Volume PCB and Keyboard PCB).....	15
8.3.6 Replacing the Fuse.....	15
8.3.7 Replacing the On/Off/Volume Knob.....	16
8.3.8 Replacing Microphone Hanger.....	16
8.3.9 Replacing Interface Cable Assembly.....	17
8.4 SOFTWARE UPGRADES.....	17
8.4.1 Hardware and Software Requirements.....	17
8.4.2 Software Installation.....	18
9 TROUBLESHOOTING	19
10. TECHNICAL ASSISTANCE	20
11. IC DATA	21
12. PARTS	24
12.1 PARTS DRAWING.....	24
12.2 PARTS LIST.....	25
13. DRAWINGS	26

1 SPECIFICATIONS

1.1 GENERAL SPECIFICATIONS

Application:

Orion™ and JAGUAR™ 725M Mobile
JAGUAR 700P and M-RK™ Vehicular Charger

Dimensions (H x W x D):**HHC (not including Cord Length)**

4.8 x 2.2 x 0.79 in.
(122 x 56 x 20 mm)

Cord:

Coiled: 24 in. (609 mm)
Stretched: 72 in. (1828 mm)

Power:**Supplied by Radio**

Range: 12 VDC ±20%
Current <500 mA

Ambient Temperature Range:

-22 to +140°F
(-30 to +60°C)

Microphone:

Integral weatherproof microphone with hookswitch

Construction:

High Impact Plastic

Display:

3-line x 12-character LCD with backlighting

Controls:

Power/Volume knob
3 x 5 keypad (backlit)
PTT
Clear
System Up
System Down
Emergency
Hookswitch

Microphone Audio*:

Sensitivity:	97 dB @ 1000 Hz @ 8 mm
Output	150 mV ± 5 dB
Impedance	600 ohms
Frequency Response	300 to 3000 Hz within the specified response mask
Distortion	<3% THD @ 1 kHz

*A separate speaker is required for audio.

1.2 ENVIRONMENTAL SPECIFICATIONS

STANDARD	PARAMETER	METHODS & PROCEDURES
MIL-STD 810F	Low Pressure	500.4
	High Temperature	501.4
	Low Temperature	502.4
	Temperature Shock	503.4
	Solar Radiation	505.4
	Rain*	506.4
	Humidity	507.4
	Blowing Dust	510.4
	Basic Transportation Vibration	514.5
	Functional/Basic Shock	516.5
	Transit Drop	516.5
	Salt Fog	509.4
U.S. Forest Service	Vibration Stability	Paragraph 2.15

*Unit withstands exposure to rain and other liquids but is not rated for immersion or driven rain.

2 IMPORTANT SAFETY INFORMATION

2.1 SAFETY SYMBOLS



The **WARNING** symbol calls attention to a procedure, practice, or the like, which, if not correctly performed or adhered to, could result in personal injury. Do not proceed beyond a **WARNING** symbol until the conditions identified are fully understood or met.



The **CAUTION** symbol calls attention to an operating procedure, practice, or the like, which, if not performed correctly or adhered to, could result in damage to the equipment or severely degrade the equipment performance.



The **NOTE** symbol calls attention to supplemental information, which may improve system performance or clarify a process or procedure.



The **ESD** symbol calls attention to procedures, practices, or the like, which could expose equipment to the effects of **Electro-Static Discharge**. Proper precautions must be taken to prevent ESD when handling circuit modules.

2.2 GENERAL WARNINGS AND CAUTIONS

The general safety precautions that follow must be observed during all phases of operation, service, and repair of this product. Failure to comply with these precautions or with specific warnings elsewhere in this manual violates safety standards of design, manufacture, and intended use of the product. M/A-COM, Inc. assumes no liability for the customer's failure to comply with these standards.

1. **SAVE THIS MANUAL** - It contains important safety and operating instructions.
2. Before using this equipment, please follow and adhere to all warnings, safety and operating instructions located on the product and in the manual.
3. Care should be taken so objects do not fall on or liquids do not spill into the equipment.
4. **DO NOT** use auxiliary equipment not recommended or sold by M/A-COM, Inc. To do so may result in a risk of fire, electric shock or injury to persons.
5. **DO NOT** operate this product in an explosive atmosphere.
6. **ELECTROSTATIC DISCHARGE SENSITIVE COMPONENTS** – This controller contains CMOS and other circuit components which may be damaged by electrostatic discharge. Proper precaution must be taken when handling circuit modules. As a minimum, grounded wrist straps must be used at all times when handling circuit modules.
7. Efficient Radio Operation: Hold the Hand Held Controller approximately two inches from your mouth and speak into the microphone at a normal voice level.

3 INTRODUCTION

This manual covers the maintenance of the Hand Held Controller. Also included are descriptions of the controls, indicators, and display, in addition to detailed circuit analyses, parts lists, and schematics.

- **General Information** - This includes safety information and systems specifications.
- **Description** - This section provides a description of the Hand Held Controller and its uses.
- **Options and Accessories** - This section provides the descriptions of available options and accessories in addition to the option and part numbers.
- **Operation** - This section describes the user interface (radio controls, indicators, and display) for the Hand Held Controller.
- **Circuit Analysis** - This section provides detailed information of the circuitry within the Hand Held Controller and programming procedures to program the Hand Held Controller and radio.
- **Programming** – This section describes the procedure to set up the Hand Held Controller to work with other equipment.
- **Service** – This section provides step-by-step procedures to disassemble and re-assemble the Hand Held Controller to replace parts. Troubleshooting information is also included.
- **Technical Assistance** – This section provides contact information for parts and service
- **IC Data** – This section describes the integrated circuits used in the Hand Held Controller.
- **Parts** – This section lists the parts and part numbers of replacement components for the Hand Held Controller

4 RELATED DOCUMENTS

Access to radio documentation is recommended to aid in the installation, operation, and maintenance of the Hand Held Controller. In most cases the radio documentation is shipped with the radio equipment. The installation and operation manual for the Hand Held Controller is packaged with the Hand Held Controller. A listing of related documents is provided to assist in verifying that you have the correct manuals for your application.

PUBLICATION NUMBER	TITLE
MM101813V1	Hand Held Controller Operator's Manual
MM101984V1	Hand Held Controller Installation Manual
LBI-38901	Orion Mobile Radio Installation Manual
LBI-39134	Orion Mobile Radio and Control Unit – Motorcycle Installation
LBI-39167	EDACS® Orion Test Unit for Non-Simulcast Applications
MM101259V1	JAGUAR 725M Mobile Radio Installation Manual
MM101258V1	JAGUAR 725M Mobile Radio Operator's Manual
AE/LZT 123 3257/1	Prism™ Enhanced Vehicular Charger Operator/Installation Manual

5 DESCRIPTION

The Hand Held Controller is a control unit that contains the functions of the Orion System Control Head and mobile microphone in a compact package. It is designed to operate in the same manner as the Orion Remote Mount Control Head. The Hand Held Controller operates the JAGUAR 725M, Orion mobile radios and is used with the MRK and JAGUAR 700 P/Pi vehicular chargers. Control functions include: Emergency, PTT, Clear, Up/Down ramp switches, volume/ On/Off switch and a microphone. A separate speaker for audio is required.

6 OPTIONS AND ACCESSORIES

HHC EQUIPMENT	CONNECTED TO	OPTION/PART NUMBER
Accessory Kit (without Siren), for remote mount, 50W TX or less	JAGUAR 725M	HBZN3M
Accessory Kit (with Siren), for remote mount, 50W TX or less	JAGUAR 725M	HBZN3P
Control Unit for Dual Control (without Siren)	JAGUAR 725M	HBZN3V
Control Unit for Dual Control (with Siren)	JAGUAR 725M	HBZN3W
Interface Cable (without Siren)	As required	CA101619V1
Interface Cable (with Siren)	As required	CA101619V5
Mounting Bracket	As required	CU101239V51

7 CIRCUIT DESCRIPTION

The power (13.6 V) is supplied to IC304 and IC305 from the J725M/Orion, which is connected by DB25 connector. IC304 and IC305 regulate it to 5.0 V, which is supplied to all the circuits of HHC.

LCD is driven directly by CPU. LCD back light is controlled by key entry via Q101 and D101-D104.

If PTT is pressed, the HHC outputs the audio signal from microphone on the front panel through the audio amplifier (IC303).

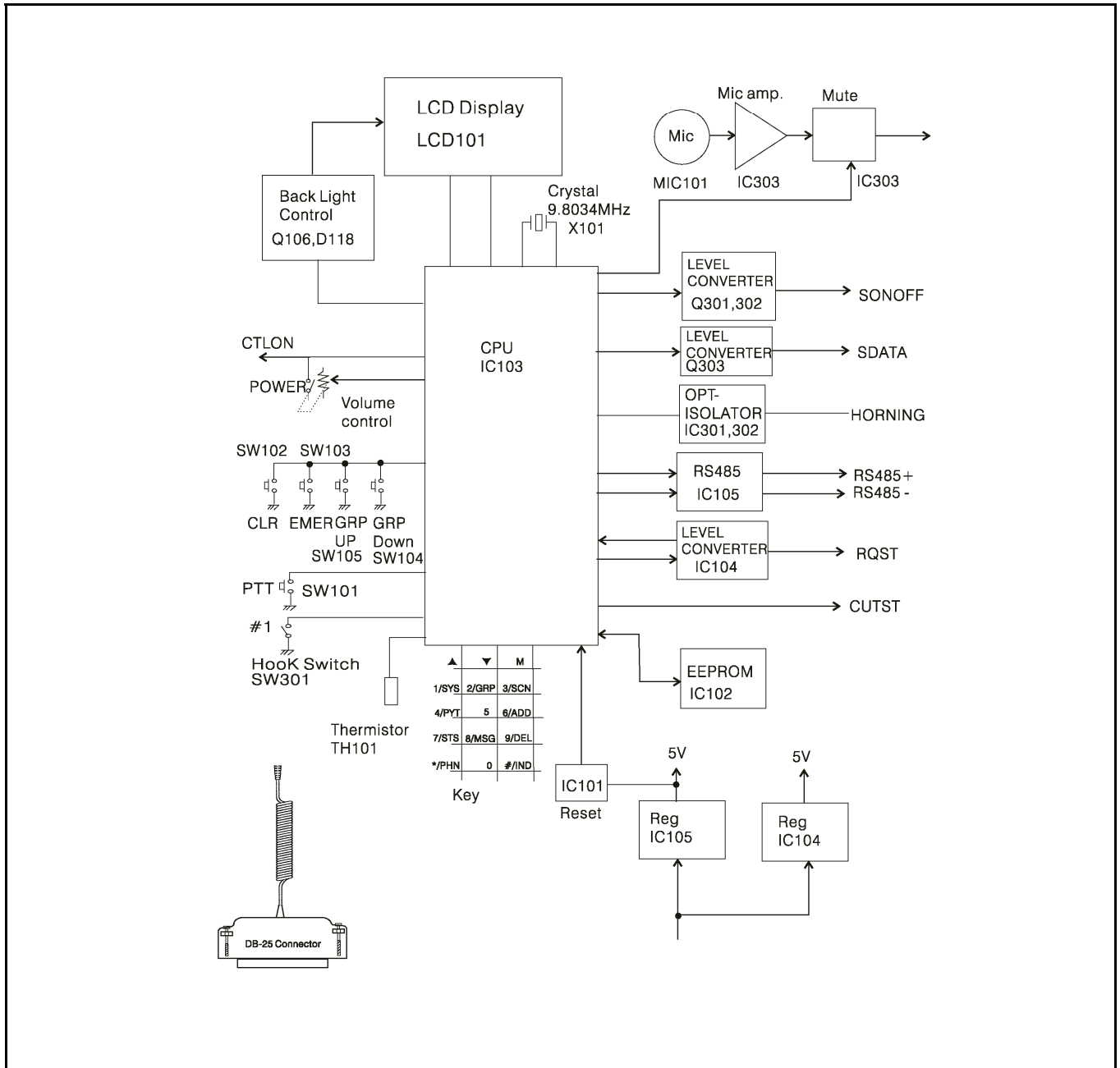

Figure 7-1: Hand Held Controller Block Diagram

8 SERVICE

8.1 CARE OF EQUIPMENT

The Hand Held Controller is housed in a rugged, polymer case. To avoid possible interruptions in communication or damage to the unit, the Hand Held Controller should not be dropped onto a hard surface or immersed in water. The casing of the Hand Held Controller can be cleaned using a clean cloth dampened with water.

8.2 PROGRAMMING

To control the radio using the Hand Held Controller using anything other than the default configuration, the Hand Held Controller must be set up through radio programming software. ProGrammer™, TQ3385, which is used to program the radio personality is also used to set up the Hand Held Controller interface. If any of the keys on the Hand Held Controller are remapped, record the keypad changes on the blank keypad form in the Keypad Remapping section of the Operator's Manual, MM101813V1. Refer to On-Line Help, Programmer, for assistance in programming the Hand Held Controller.

8.3 HHC DISASSEMBLY AND REASSEMBLY

8.3.1 Tools required

- Small hex head screwdriver
- Small flat-head screwdriver
- Small socket driver
- Small needle nose pliers
- Soldering iron
- Solder

8.3.2 Housing Disassembly and Reassembly

8.3.2.1 Housing Disassembly



Figure 8-1: Location of housing screws

1. Remove the 4 large cap head screws, M1.7X10, from the top back and center of the housing. Retain screws for reassembly.

2. Remove the two pan head screws, M1.7X7, from the bottom outside of the back housing. Retain screws for reassembly.
3. Remove the two smallest pan head screws, M1.7X5, screws from the bottom center of the back housing. Retain screws for reassembly.
4. Insert a small flat head screwdriver between front and back housing and gently pry the housings apart. DO NOT pull the sections more than a few inches apart as a flex cable connects boards inside the front and back housings.
5. On Back PCB, remove flex ribbon cable #1 from connector by pulling the cable straight away from the connector.

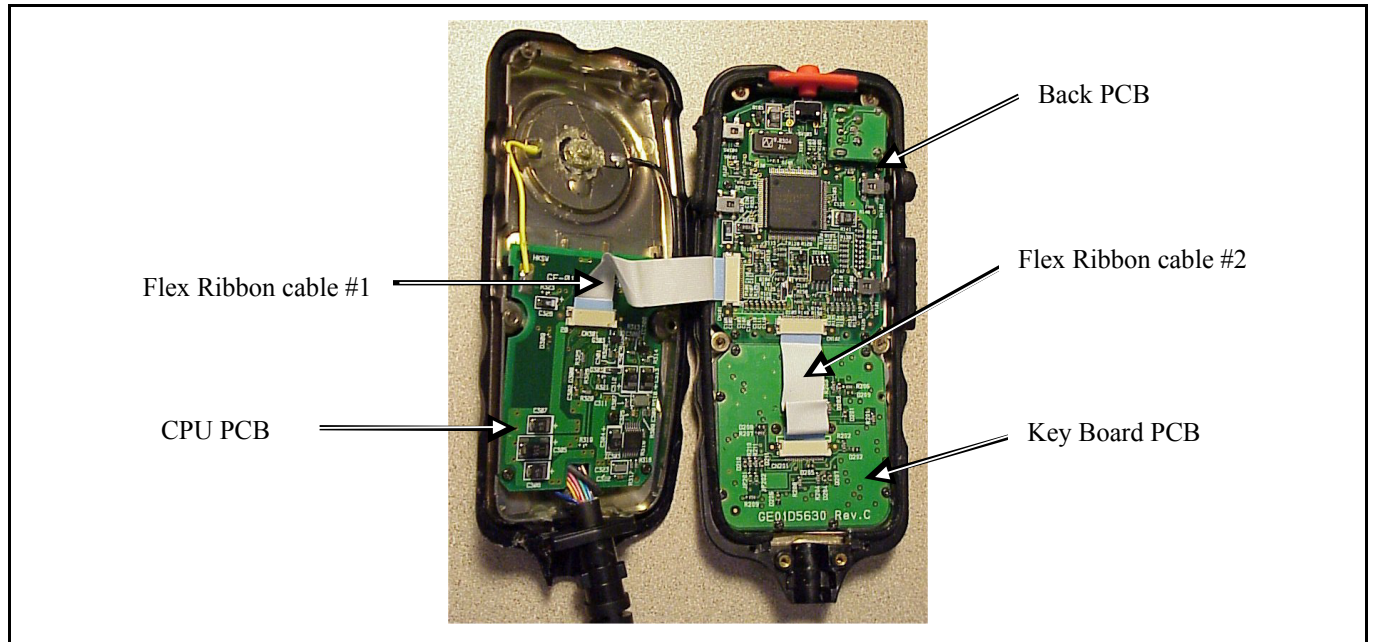

Figure 8-2: Location of PCBs and Flex Ribbon Cables

8.3.2.2 Housing Reassembly

1. Reconnect the flex ribbon cable on the Back PCB Assembly by aligning the end of the cable into the connector and pushing firmly. Note that printed side of flex ribbon cable should be facing towards the Back PCB.
2. Reassemble front housing to back housing making sure that gasket is fitted into the front housing and that the cable fits into the slot at the bottom of the back housing.
3. Replace all housing screws and tighten. Tighten the cap head screws and the smaller pan head screws to 98N.m.. Tighten the larger pan head screws to 79N.m..

8.3.3 Replacing Keypad

1. Disassemble housing per Section 8.3.2.1.
2. Remove the housing gasket. Save for reassembly unless damaged.
3. Remove the flex ribbon cable originating from Volume PCB from connector on Keyboard PCB by pulling the cable straight out and away from the connector.

4. Remove the 11 screws on the Keyboard PCB and remove board from housing. Retain the screws for reassembly.
5. Remove the rubber Keypad and discard.

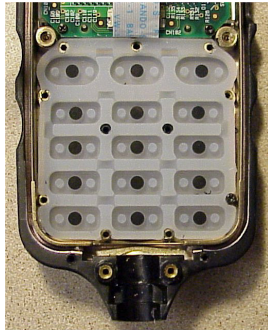

Figure 8-3: Rubber Keypad

6. Insert the replacement Keypad into the front housing making sure that the buttons fit into the holes in the housing.
7. Position the Keyboard PCB over the Keypad so that the part number of the board is facing in and towards the controller.

8.3.4 Replacing Flex Ribbon Cable #1 (between Back Board and Volume PCB)

1. Disassemble the housing using steps in Section 8.3.2.1.
2. Disassemble the On/Off Volume Knob:
 - Pull out center rubber insert located on the knob. The red plastic indicator piece should come out with the rubber insert.
 - Remove the countersunk head screw and lift knob out of front housing. Remove the O-Ring from the hole if it did not come out with the knob. Retain parts for reassembly.
3. Remove the five screws, M1.4x4, which hold the Volume PCB to the front housing.
4. Gently pull the Volume PCB a few inches away from the front housing.
5. Unfold the flex ribbon cable and remove it from Volume Board connector by pulling it straight out away from the connector. Discard the flex ribbon cable.
6. Insert the replacement cable into the connector on the Volume Board with the printed side of the cable facing towards the board. Push in securely.
7. Place the Volume PCB on the front housing with ribbon cables facing towards the inside. Align the screw holes.
8. Insert the five screws and tighten to 69N.m..
9. Plug the flex ribbon cable firmly into the Back Board Assembly with printed side facing board.
10. Install the On/Off/Volume Knob per Section 8.3.7.
11. Reassemble housing per Section 8.3.2.2.

8.3.5 Replacing Flex Ribbon Cable #2 (between Volume PCB and Keyboard PCB)

1. Disassemble the housing using steps in Section 8.3.2.1.
2. Remove the ribbon cable from both the Volume Board Assembly and the Keyboard Assembly connectors by pulling the cable straight out and away from the connectors. See Figure 8-2: Location of PCBs and Flex Ribbon Cables. Discard the flex ribbon cable.
3. Insert the replacement ribbon cable into the Volume Board Assembly with printed side of cable facing the board.
4. Insert the other end of the flex ribbon cable into the connector on the Keyboard assembly with the printed side of cable facing the board. Do not twist the cable.
5. Reassemble housing per Section 8.3.2.2.

8.3.6 Replacing the Fuse

1. Disassemble the housing using steps in Section 8.3.2.1.
2. Remove the 3 Pan Head Tapping screws, M1.7x3, holding the Back PCB to back housing and lift up.
3. Carefully turn the board over to expose the connectors from the HHC Interface cable.
4. Remove smaller wires by grasping the group of wires and pulling away from the connector.
5. Remove the larger group of wires by grasping the group of wires and pulling away from the connector.
6. Locate fuse F301 on the bottom left side of the board. See Figure 13-1 for location of fuse.
7. Unsolder the fuse and discard.
8. Position replacement fuse verifying that it is the correct size and type.
9. Solder the replacement fuse to the board.



Excessive heat from solder may damage board.

10. Reinsert the two groups of cable wires into connectors on the replacement Back PCB. The smaller of the two groups should be inserted with the white wire toward the outside of the housing. The larger group should be inserted with the brown wire closest to the smaller connector. If cable wire colors differ from those listed, the user should observe the proper keying when reinserting the wires.
11. Carefully turn board so that the connector side is facing the back housing and verify that ground and hookswitch connections have not been damaged.
12. Place the board on the housing matching mounting holes. Insert and tighten the 3 screws to 69N.m.
13. Reassemble the housing per Section 8.3.2.2.

8.3.7 Replacing the On/Off/Volume Knob

1. With front of the controller facing you, pull out center rubber insert located on the knob. The red plastic indicator piece should come out with the rubber insert.
2. Remove the countersunk head screw and lift knob out of front housing. Remove the O-Ring from the hole if it did not come out with the knob. Discard parts.
3. With the controller facing you, place the replacement knob without the rubber insert into the hole with the notch on the inside of the knob at approximately a 9:00 position. Slowly turn the knob counterclockwise until it drops into position.
4. While holding the knob in this position, insert and tighten the replacement screw.
5. Insert the replacement red plastic indicator into the rubber insert. Place this assembly into the knob making sure that the red indicator fits into the notch in the knob.

8.3.8 Replacing Microphone Hanger

1. Disassemble the housing using steps in Section 8.3.2.1.
2. With a sharp knife, carefully remove the clear sealant covering around the hex nut.

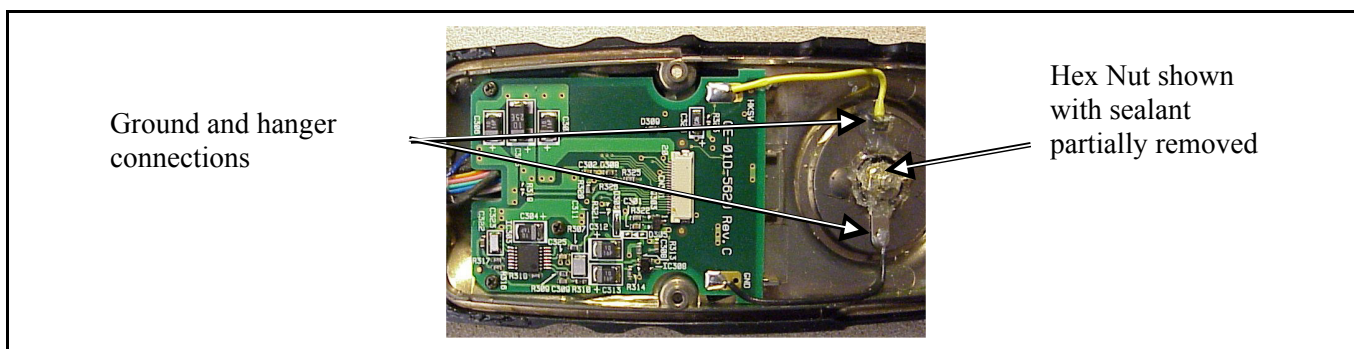

Figure 8-4: Hex Nut and Ground and Hanger connections

3. Hold the hex nut stationary with a socket driver or a pair of needle nose pliers as you unscrew the hanger from the back of the housing. Discard the hanger. Retain the hex nut for reassembly.



While it is not necessary to unsolder the ground and hanger connections to replace the microphone hanger, care should be taken not to disturb these connections.

4. Insert the replacement microphone hanger into the hole. While holding it firmly in place, thread the hex nut down the shaft of the microphone hanger and tighten.
5. Remove any old sealant from the top of the hex nut facing the inside of the controller.
6. Cover the hex nut and the surrounding hole in the back of the housing with replacement sealant. The silicon must be electrical grade and non-corrosive such as Dow Corning 3145 RTV clear, group II adhesive sealant (MIL-A-46146) or equal. Allow the sealant to cure according to the manufacturer's instructions prior to reassembling the controller.
7. Reassembly housing per Section 8.3.2.2.

8.3.9 Replacing Interface Cable Assembly

1. Disassemble the housing using steps in Section 8.3.2.1.
2. Remove the 3 Pan Head Tapping screws, M1.7x3, holding the Back PCB to back housing and lift up.
3. Carefully turn the board over to expose the connectors from the HHC Interface cable.
4. Remove smaller wires by grasping the group of wires and pulling away from the connector.
5. Remove the larger group of wires by grasping the group of wires and pulling away from the connector.
6. Insert the larger group of wires on the replacement Interface Cable into the larger connector on the Back PCB.
7. Insert the smaller group of wires on the replacement Interface Cable into the smaller connector on the Back PCB.
8. Reassemble the housing per Section 8.3.2.2.

8.4 Software Upgrades

It may become necessary to install new software into the Hand Held Controller. The software can be installed using a PC connected to a Programming Interface Adapter.

8.4.1 Hardware and Software Requirements



Figure 8-5: Programming Interface Adapter – TQ3414

The following will be required for software installation:

- Hand Held Controller
- Programming Interface Adapter – TQ3414
- 12V power supply
- Software Media kit, ST101680V11, from M/A-COM
- PC running Windows® 95, Windows 98, or Windows NT
- Serial cable with 9-pin male connector on one end and the appropriate connector for PC COM port on the other.

8.4.2 Software Installation

Refer to Figure 8-6

1. Connect serial cable to the available Com port on the PC. Connect the other end to the HHC Interface Adapter at the connector labelled "PC".
2. Connect 12VDC to the HHC Interface Adapter.
3. Connect the HHC cable to the HHC Interface Adapter at the connector labelled "HANDHELD CONTROLLER".
4. Following instructions contained in the Software Release Notes for the particular software release.

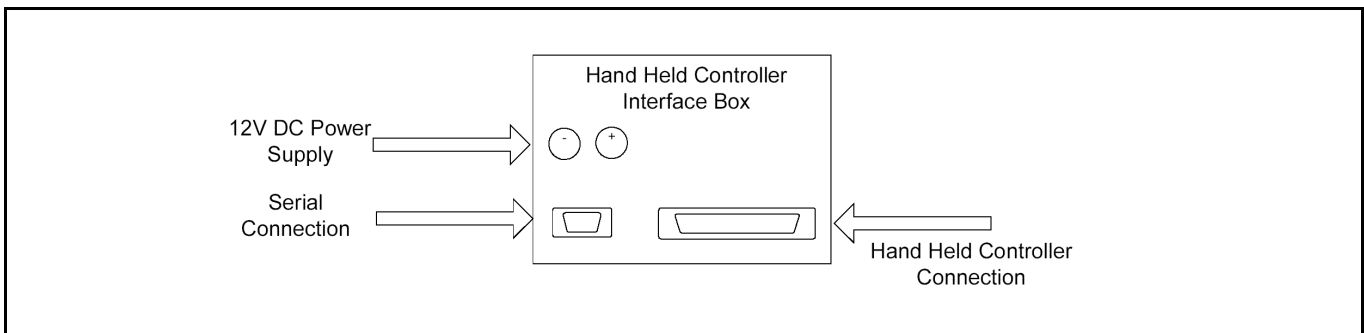

Figure 8-6: Programming Interface Adapter Connections

9 TROUBLESHOOTING

SYMPTOM	POSSIBLE CAUSE/REMEDY
Power switch does not operate.	Defective power switch (VR101): Replace the defective component.
Display does not light.	Faulty connection between radio and HHC: Reconnect the MIC cable to the radio.
Front keys do not work.	<ol style="list-style-type: none"> 1. Defective Keyboard PCB Assembly: Replace the Keyboard PCB Assembly. 2. Faulty connection between Keyboard PCB and CPU PCB. 3. Reconnect the Keyboard PCB and CPU PCB.
PTT does not work.	Defective SW101: Replace the defective component.
Volume control does not operate.	Defective VR101: Replace the defective component.
LCD does not display correctly.	Defective LCD or CPU (IC103): Replace the defective component.

10. TECHNICAL ASSISTANCE

For assistance with the maintenance of the Hand Held Controller, contact M/A-COM's Technical Assistance Center:

Phone: 1-800-528-7711 (U.S. and Canada)
434-385.2400 (International)

Fax: 434-455-6712

e-mail: tac@tycoelectronics.com

11. IC DATA

IC101 S80941ANMP-DD5

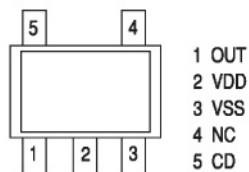

IC102 BR24C02FV-WE2

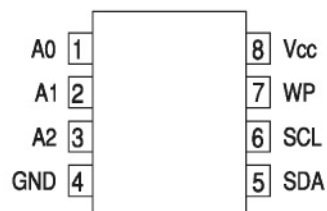

A0, A1, A2: Slave Address Setting
 SCL: Serial Data Clock
 SDA: Serial Data Input/Output
 WP: Write Protect

IC103 HD64F3064-BF25

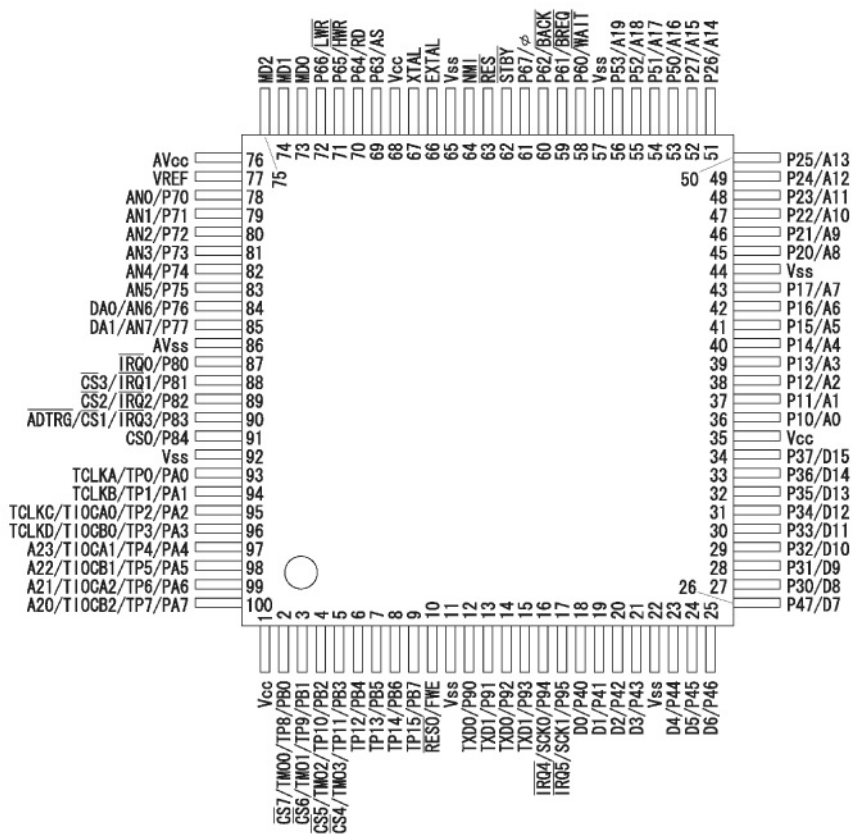

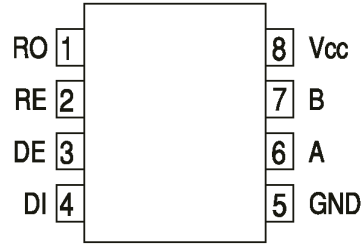
IC104 MAX485CSA-BF25

RO: Receiver Output
RE: Receiver Output Enable
DE: Driver Output Enable
DI: Driver Input
A: Non-Inverting Receiver Input/Non-Inverting Driver Output
B: Inverting Receiver Input/Inverting Driver Output

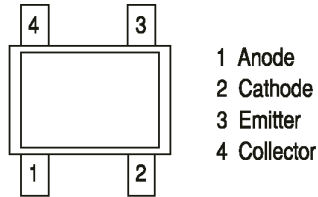
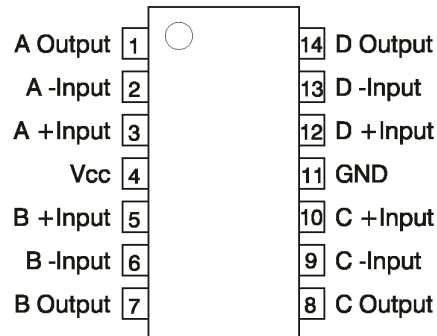
IC301/302 PC356NT**IC303 NJM2058V**

IC304/305 TA48M05F

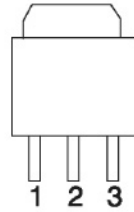

- 1: Input
- 2: Output
- 3: GND

IC306 TC4S69F

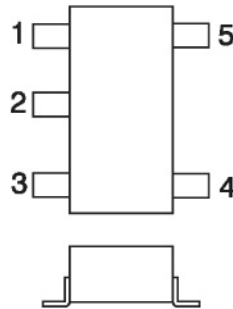

- 1 NC
- 2 IN A
- 3 Vss
- 4 OUT X
- 5 VDD

IC306 TC4S69F

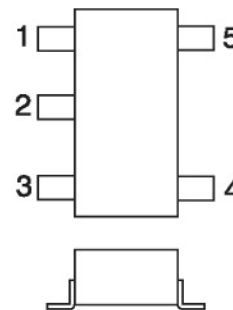

- 1 Input/Output
- 2 Output/Input
- 3 Vss
- 4 Control
- 5 VDD

12. PARTS

12.1 PARTS DRAWING

**Hand Held Controller
Exploded View**

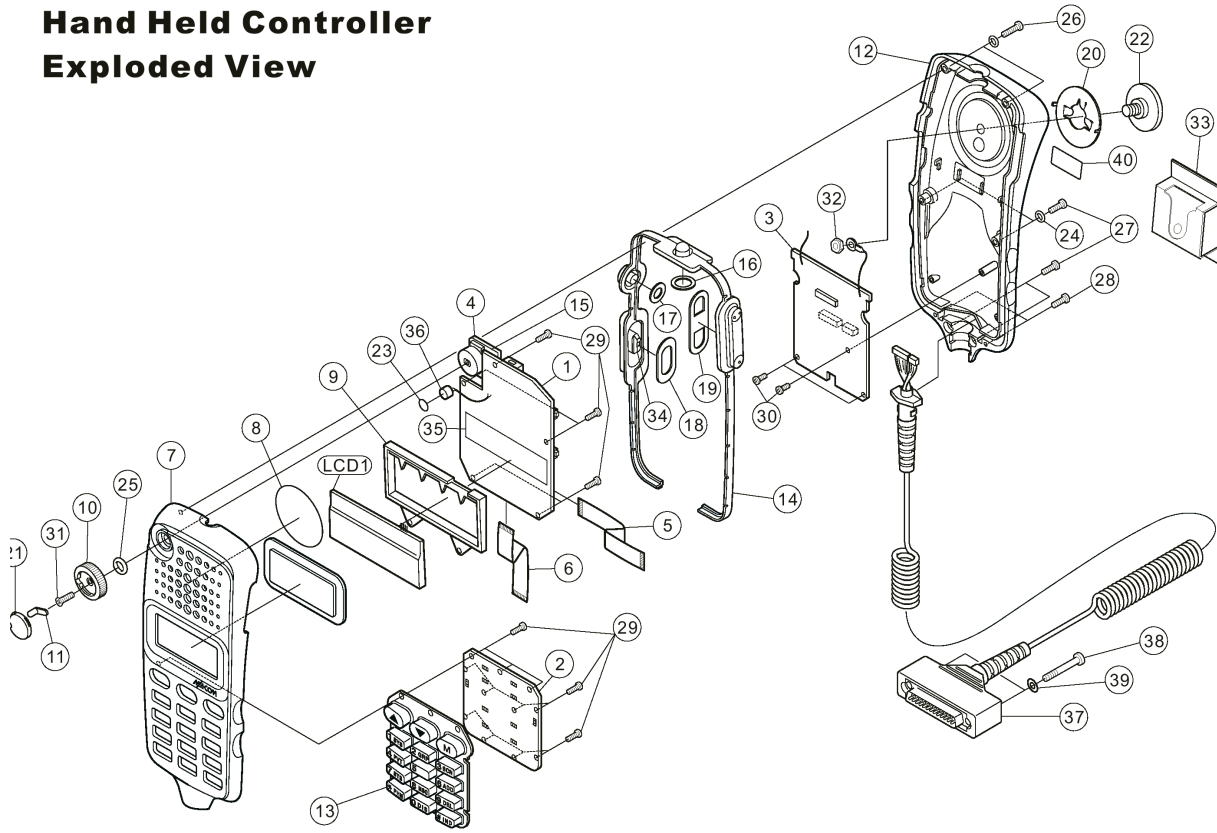

12.2 PARTS LIST

The piece numbers in the first column refer to the parts drawing on the previous page. Part numbers listed may be ordered from M/A-COM using the contact numbers in Section 10.

PC #	PART DESCRIPTION	PART NUMBER
1	CPU PCB ASSEMBLY	
2	KEY BOARD PCB ASSEMBLY	
3	BACK PCB ASSEMBLY	
4	VOLUME PCB ASSEMBLY	
5	FLEX RIBBON CABLE #1	GE-02D-6080
6	FLEX RIBBON CABLE #2	GE-02D-6090
7	FRONT ASSEMBLY	
	FRONT CASE	
	LCD WINDOW	
8	SPEAKER GRILLE COVER	
9	LCD BRACKET	
10	VOLUME KNOB KIT (includes items 10,11,21,25, and 31)	GA-03D-8960
11	POINTER	
12	REAR CASE	
13	RUBBER KEY PAD	GE-01D-5400
14	RUBBER BUTTON KIT (includes items 14, 16, 17, 18, 19, and 34)	GA-03D-8970
15	VOLUME BRACKET	
16	WASHER(EMERGENCY)	
17	WASHER(CLEAR)	
18	WASHER(PTT)	
19	WASHER(ROCKER)	
20	BASE	
21	CAP (VR)	
22	D-CLIP LUG	
23	MIC SHIELD	
24	O RING (SCREW)	
25	O RING (VR)	
26	SCREW, LR PAN HEAD	
27	SCREW, LR PAN HEAD	
28	SCREW, PAN HEAD TAPPING	
29	SCREW, PAN HEAD TAPPING	
30	SCREW, PAN HEAD TAPPING	
31	SCREW, COUNTERSUNK HEAD	
32	NUT	
33	HANGER BRACKET ASSEMBLY	GA-01D-5800
	HANGER BRACKET	
	SCREW, TYPE AB	
34	PTT BUTTON BRACKET	
35	LCD OPTICAL SPREAD FILM	
MC101/36	MICROPHONE	
37	MIC CABLE ASSEMBLY	GA-01D-5560
	CONNECTOR, HOUSING	
	MIC CABLE	
38	DB-25 SCREW	
39	DB-25 WASHER	
40	MODEL LABEL	
	FUSE	SMF-3.2ACT
	SCREW KIT	GA-03D-8950

13. DRAWINGS

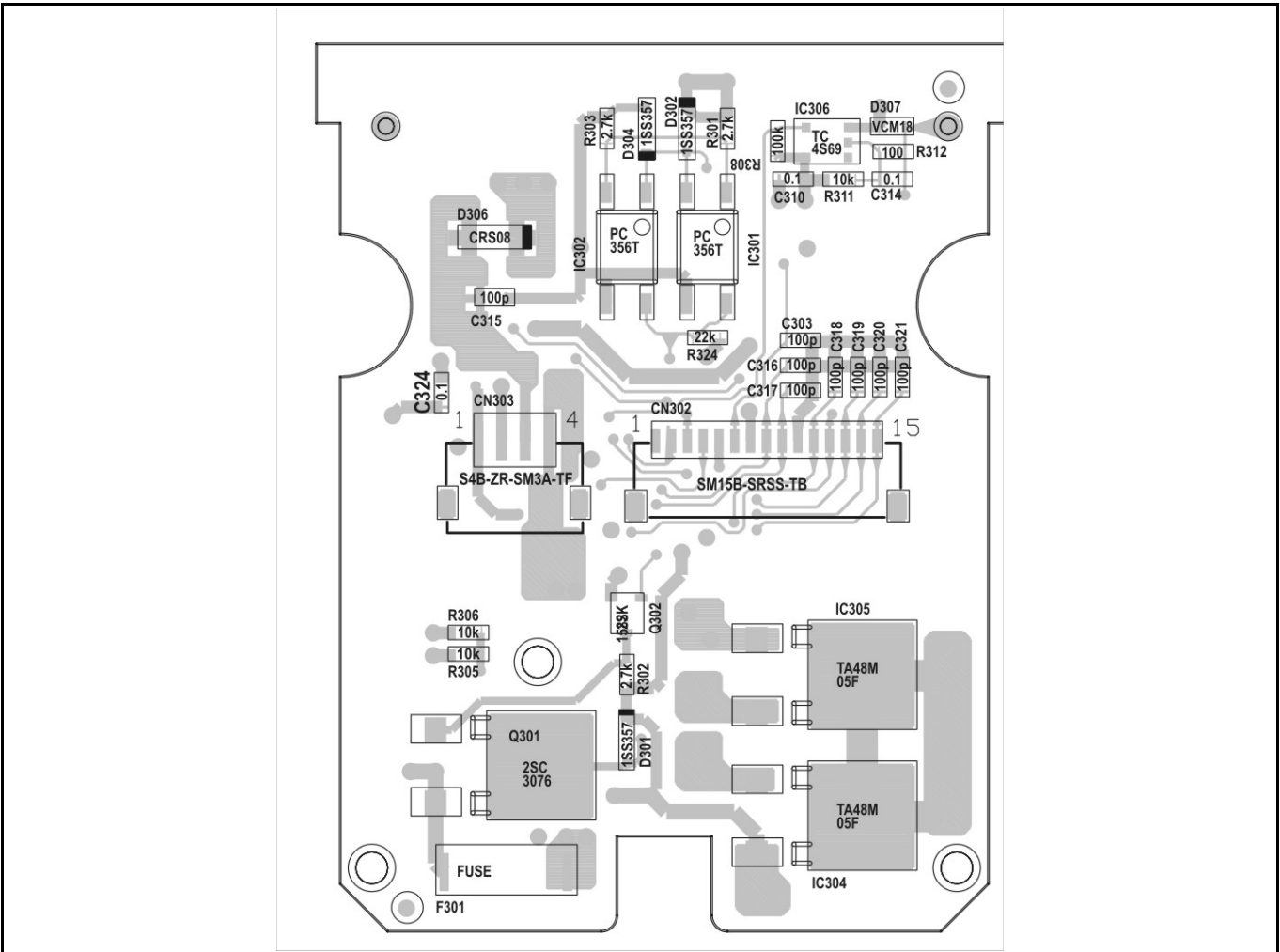

Figure 13-1: Back PCB Layout - Bottom

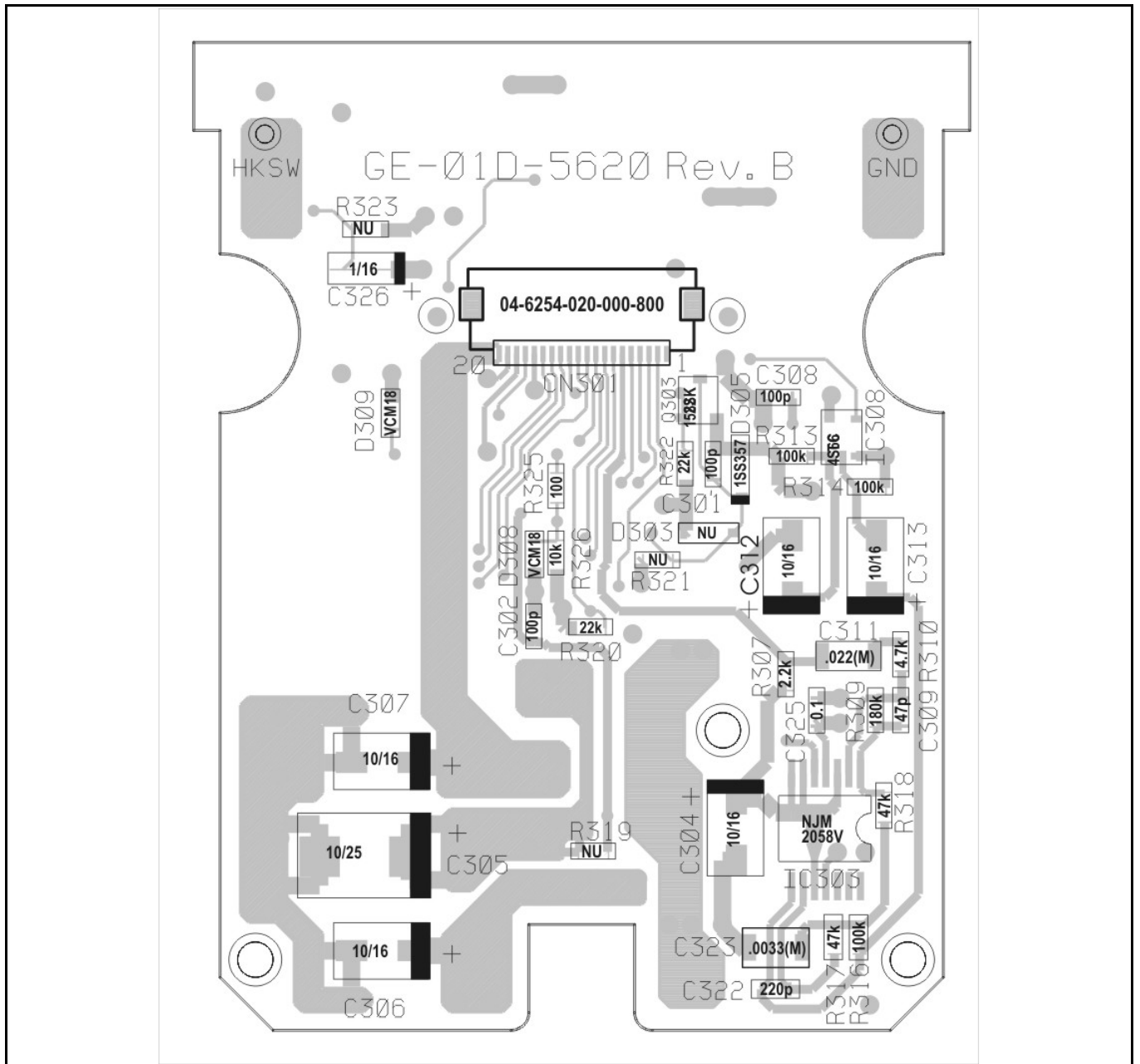

Figure 13-2: Back PCB Layout - Top

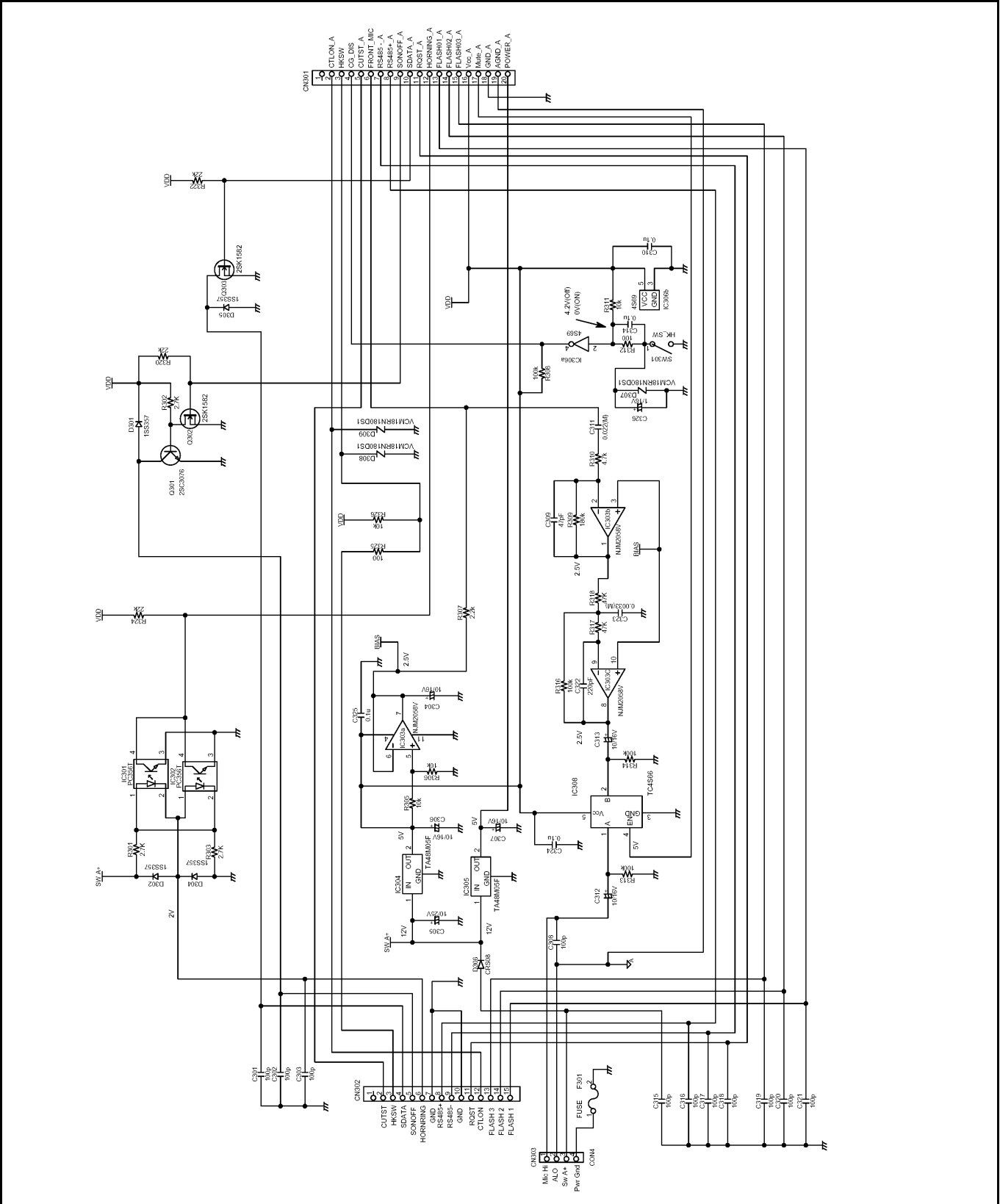

Figure 13-3: Back PCB Schematic

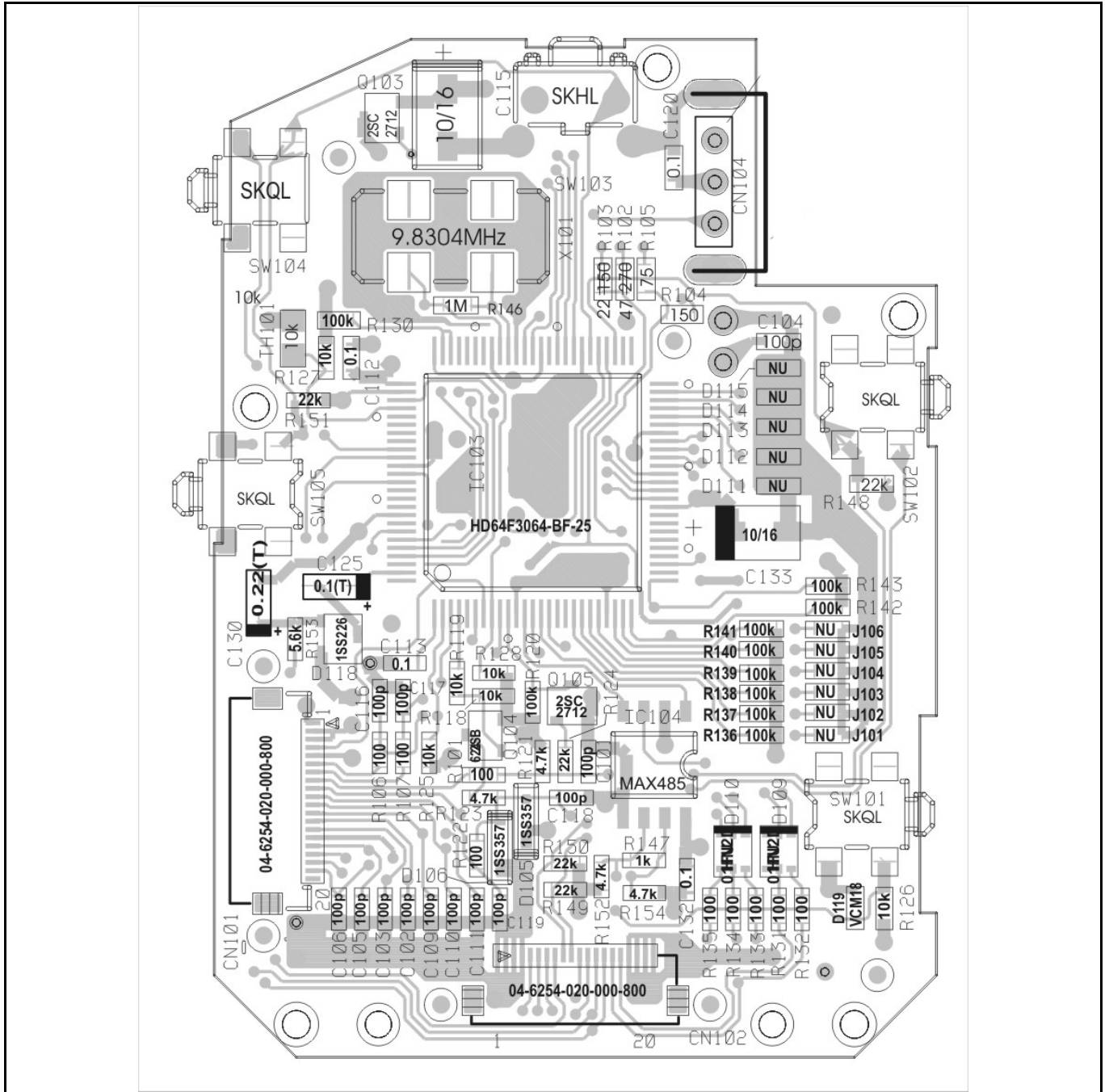

Figure 13-4: CPU PCB Layout - Bottom

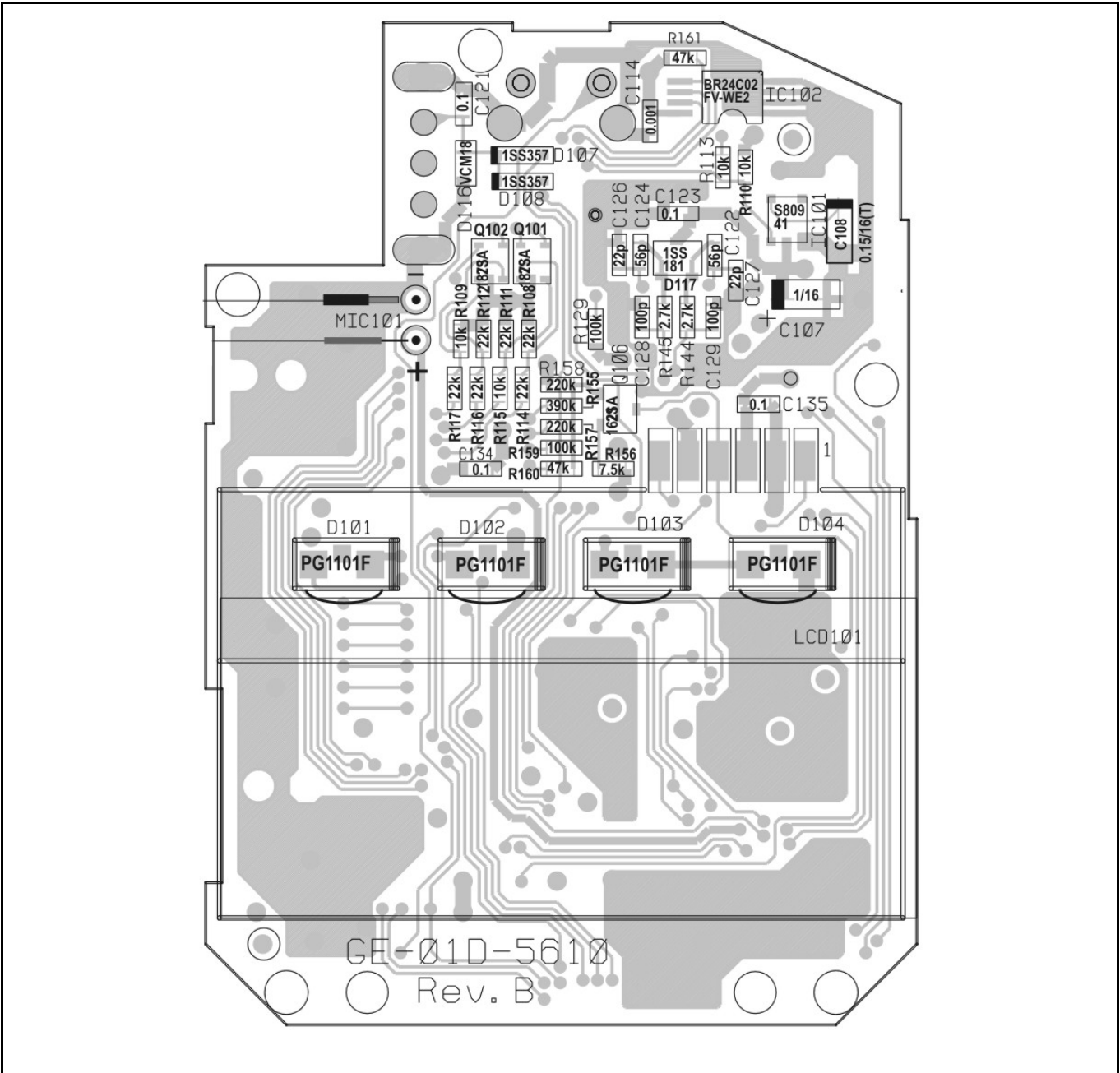

Figure 13-5: CPU PCB Layout – Top

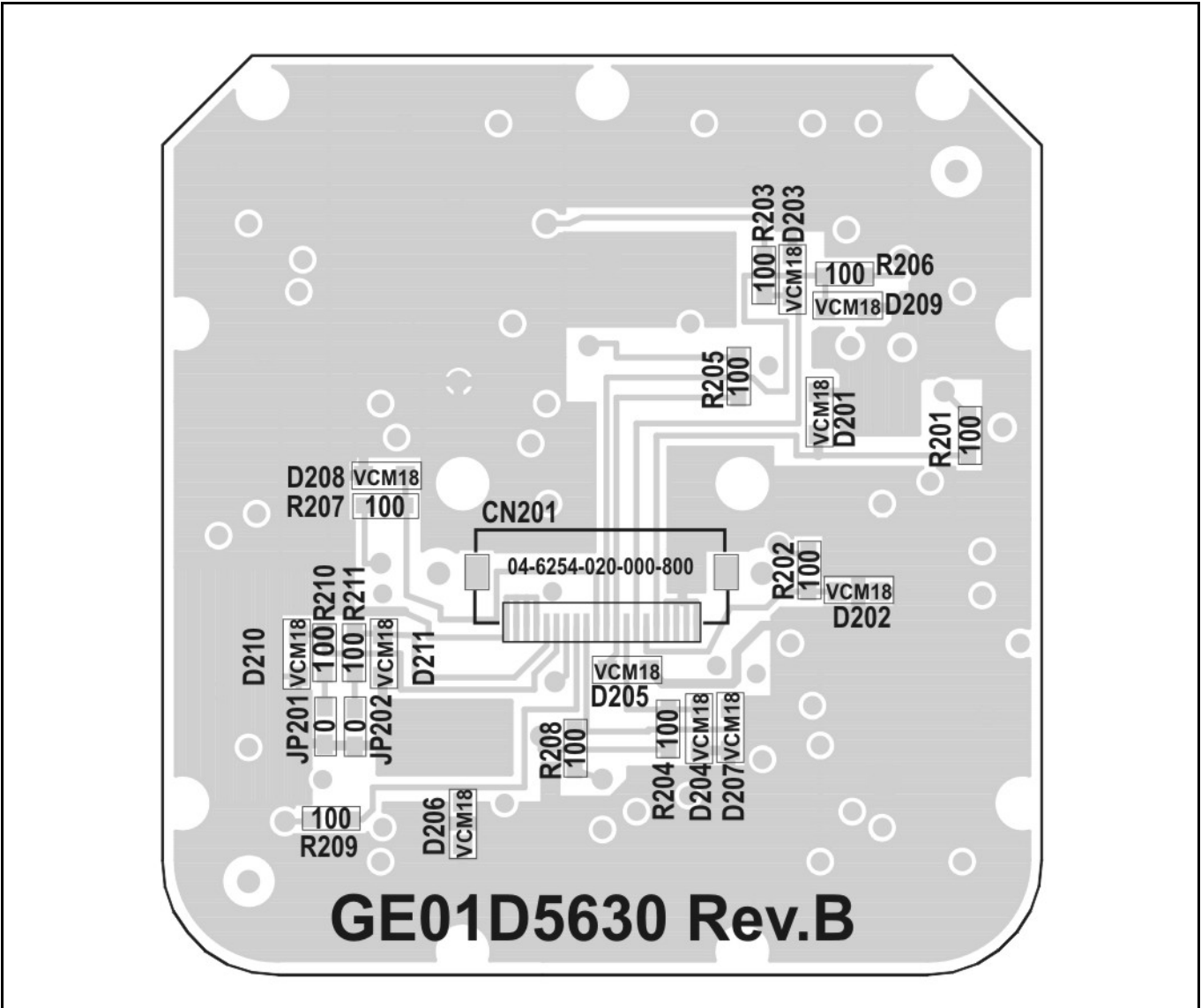

Figure 13-7: Key Board PCB Layout – Bottom

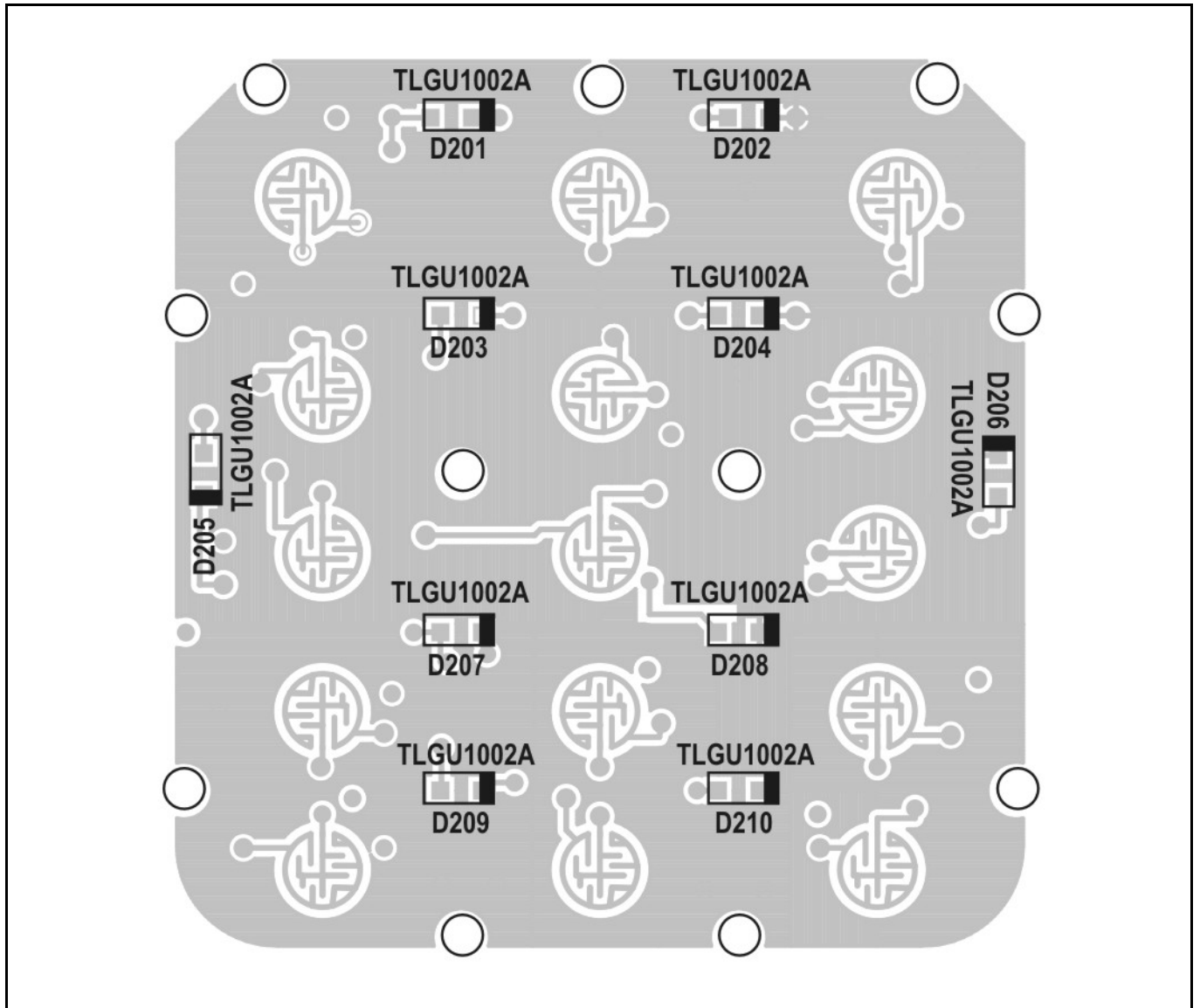

Figure 13-8: Key Board PCB Layout - Top

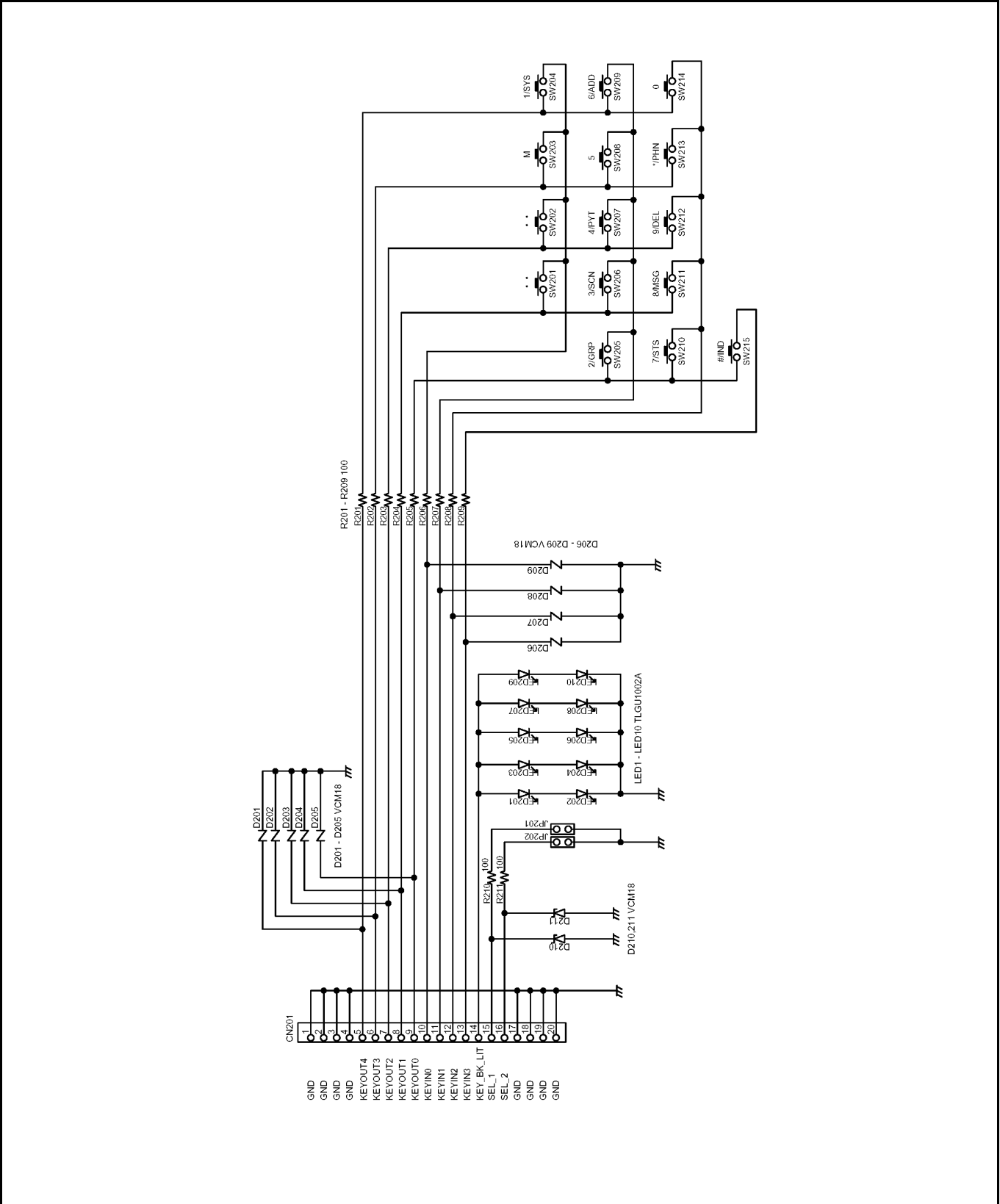

Figure 13-9: Key Board PCB Schematic



This page intentionally left blank

