

future
The Future of Mobile Radio



MASTR® III Emergency Power Options

- CH1L - Automobile Battery 120 VAC/60 Hz
- CH1M - Automobile Battery 230 VAC/50 Hz
- CH1R - GEL CELL Battery 120 VAC/60 Hz
- CH3A - GEL CELL Battery 230 VAC/50 Hz

CAUTION

THESE SERVICE INSTRUCTIONS ARE FOR USE BY QUALIFIED PERSONNEL ONLY. TO AVOID ELECTRIC SHOCK DO NOT PERFORM ANY SERVICING OTHER THAN THAT CONTAINED IN THE OPERATING INSTRUCTIONS UNLESS YOU ARE QUALIFIED TO DO SO. REFER ALL SERVICING TO QUALIFIED SERVICE PERSONNEL.

WARNING: TO PREVENT FIRE OR ELECTRIC SHOCK HAZARD DO NOT EXPOSE THIS PRODUCT TO RAIN OR MOISTURE.

CAUTION: TO PREVENT ELECTRIC SHOCK DO NOT USE THIS (POLARIZED) PLUG WITH AN EXTENSION CORD, RECEPTACLE OR OTHER OUTLET UNLESS THE BLADES CAN BE FULLY INSERTED TO PREVENT BLADE EXPOSURE.



 <p>The lightning flash and arrowhead within the triangle is a warning sign alerting you of "dangerous voltage" inside the product.</p>	 <p>CAUTION RISK OF ELECTRIC SHOCK DO NOT OPEN</p> <p>CAUTION: TO REDUCE THE RISK OF ELECTRIC SHOCK. DO NOT REMOVE COVER (OR BACK). NO USER-SERVICABLE PARTS INSIDE. REFER SERVICING TO QUALIFIED SERVICE PERSONNEL.</p>	 <p>The exclamation point within the triangle is a warning sign alerting you of important instructions accompanying the product.</p>
See Marking On Bottom/Back Of Product		

TABLE OF CONTENTS

	Page
MIII BASE STATION EMERGENCY POWER OPTIONS	1
CHARGER SPECIFICATIONS	2
EMERGENCY POWER OPTION SYSTEM DESCRIPTION	2
CIRCUIT DESCRIPTION AND THEORY OF OPERATION FOR THE BATTERY CHARGER	2
GENERAL	2
MAIN CHARGING CIRCUITRY	3
OVERCURRENT PROTECTION	3
INPUT OVERVOLTAGE PROTECTION	3
OVERTEMPERATURE PROTECTION	4
BATTERY SWITCHING OPERATION	4
DEEP DISCHARGE PROTECTION	4
ERROR FLAG SIGNALS	4
INTERNAL BIAS VOLTAGE SOURCES	4
FLOAT VOLTAGE ADJUST	4
TROUBLESHOOTING PROCEDURE	5
PARTS LIST	
BATTERY & HARDWARE KITS	5
BATTERY CHARGER	10
SCHEMATIC DIAGRAM	
50 Hz CHARGER	6
60 Hz CHARGER	7
ASSEMBLY DIAGRAM	
50 Hz CHARGER	8
60 Hz CHARGER	9
MASTR III STATION	13
INTERCONNECTION DIAGRAM	12
INSTALLATION INSTRUCTIONS	16

NOTICE!

Repairs to this equipment should be made only by an authorized service technician or facility designated by the supplier. Any repairs, alterations or substitution of recommended parts made by the user to this equipment not approved by the manufacturer could void the user's authority to operate the equipment in addition to the manufacturer's warranty.

NOTICE!

The software contained in this device is copyrighted by the M/A-COM Private Radio Systems, Inc. Unpublished rights are reserved under the copyright laws of the United States.

This manual is published by **M/A-COM Private Radio Systems, Inc.**, without any warranty. Improvements and changes to this manual necessitated by typographical errors, inaccuracies of current information, or improvements to programs and/or equipment, may be made by **M/A-COM Private Radio Systems, Inc.**, at any time and without notice. Such changes will be incorporated into new editions of this manual. No part of this manual may be reproduced or transmitted in any form or by any means, electronic or mechanical, including photocopying and recording, for any purpose, without the express written permission of **M/A-COM Private Radio Systems, Inc.**

EMERGENCY POWER OPTIONS

- CH1L - AUTOMOBILE BATTERY EMERGENCY POWER (120 Vac/60 Hz VERSION); Adds a charger and power harness cabling. The automobile battery is external to the base station cabinet and is purchased separately by the customer for field installation.
- CH1M - AUTOMOBILE BATTERY EMERGENCY POWER (230 Vac/50 Hz VERSION) Same as CH1L except for international version charger.

- CH1R - GEL CELL BATTERY EMERGENCY POWER (120 Vac/60 Hz VERSION) Adds a charger, power cable harnessing, and a gel cell shelf. The four 12V 25 AH gel cell batteries are not included in this option. Each of the batteries can be ordered for field installation per drop ship index item, V2401.
- CH3A - GEL CELL BATTERY EMERGENCY POWER (230 Vac/50 Hz VERSION) Same as CH1R except for international version charger.

WARNING

Options CH1L, CH1M, CH1R & CH3A are emergency power backup options only. These options are activated only when the AC power is interrupted. To ensure proper operation the option AC power cord **MUST** be connected to the same receptacle, or at a minimum, the same MAIN, as the station that the batteries are backing up. Also for proper charging, the charger **MUST** remain connected to the AC MAIN when the MAIN is active. **FAILURE TO COMPLY COULD RESULT IN PERMANENT DAMAGE TO THE BATTERY.**

		CH1L	CH1M	CH1R	CH3A
344A3168P1	10 AMP CHARGER, 60 Hz	1		1	
344A3168P2	10 AMP CHARGER, 50 Hz		1		1
344A3696G1	CHARGER KIT	1	1		
344A3696G2	CHARGER KIT			1	1
19C852074P1	SUPPORT	1	1	1	1
19C852074P2	SUPPORT	1	1	1	1
19D903719P1	BATTERY STANDBY SHELF			1	1
19C852193P1	BATTERY COVER PANEL			1	1
19D903635	INTERCONNECT DIAGRAM	X	X	X	X
19D902845P5	APPLICATION ASSEMBLY	X	X		
19D424751P6	APPLICATION ASSEMBLY			X	X
344A4051P1	INSTALLATION INSTRUC.			X	X

344A3168 CHARGER SPECIFICATIONS

Input Voltage Range (For Normal Operation State)	P1: 121 Vac ±10% for trickle charge or full rated charge 121 Vac ±20% for trickle charge only P2: 230 Vac ± 10% for trickle charge or full rated charge 230 Vac ± 15% for trickle charge only
Input Voltage Range (For Emergency Power State)	< 70% of nominal line voltage
Line Voltage Surge Protection	P1: 150 Vac rated M.O.V. P2: 275 Vac rated M.O.V.
Charger Output Voltage	13.6 Vdc
Rated Charger Current	10.0 amps
Load Current Knee	11.0 ±1.0 amps
Short Circuit Current	4.0 amps max
Charger Output Voltage Ripple	< 100 mV p-p (@ + 25°C) < 200 mV p-p (@ - 30°C)
Duty Cycle (Full Charge) (Trickle Charge)	100% for 8 hours 100% continuously
Status Line Output (Normal Operation) (Emergency Power)	23.5 ±0.5 Vdc Impedance >1 Mohm
Current Sourcing Capability (A+ to SW A+ port in Emergency Power State)	33 amps max
Deep Discharge Cutout Voltage	10.5 Vdc
Temperature Range	-30° to +60°C
Weight	22 lbs.

EMERGENCY POWER OPTION SYSTEM DESCRIPTION

The 344A3168 series of chargers are designed to interface with 19A149978P1, Rev. B or later, or 19A149978P2, Rev. A or later series power supplies. To retrofit the charger with 19A149978P1, Rev. 0 or A power supplies, or 19A149978P2, Rev. 0 power supplies, Field Mod Kit 344A4123G1 with mod instructions 344A4124P1 must be used. Under normal operating conditions (defined as having the nominal input line voltage plus a tolerance) the relays K1, K2, and K3 are energized. 344A3168 becomes a charger, providing a full charge of up to 10 amps out of the A + port to the battery system at a constant voltage until the battery system is fully charged. If the charger attempts to source more than 10 amps because, for example, a battery has been deep discharged, then the charger's current foldback circuitry will drop the charger voltage for a short time until the battery has been recharged enough to no longer sink more than 10 amps. The charger will then revert to providing a constant voltage charge. The charger then maintains a trickle charge indefinitely on the battery system to maintain a full charge.

Without the emergency power options, the power supply's 10 ohm, 50 watt bleeder resistor R1 is tied to ground through an external strap, P802. With the emergency power options, P802 is removed, allowing K3, the SW GND (switched ground) relay in the charger to ground the bleeder resistor through J2-3 to provide normal operation of the supply. The STATUS line (J2-1) provides a + 24 Vdc signal to the alarm tone circuitry indicating the system is in the normal operating state.

When the input line voltage drops below 70% of the nominal line voltage, the charger reverts to the emergency power state. Current, instead of being sourced from the A + port to the battery system, is now being delivered from the battery. K1 de-energizes, and K2 remains energized. This allows up to 33 amps to flow from the battery to the charger A + port, out of the SW A + (SWitched A +) port and through the SW A + port of the power supply. The current is then fed through the power supply's load fuses and out through the harnesses to run the base station's power amplifier and receiver/system circuitry. K3 also de-energizes, opening the bleeder resistor circuit. This removes the 1.2 amp load on the battery that would have drained the battery at a faster rate. The STATUS line becomes an open circuit to the alarm tone circuitry indicating the system is in the emergency power state.

When the battery system has discharged to approximately 10.5 Vdc the charger de-energizes K2 to prevent a deep discharge of the battery system. This is important for both gel cells and automobile batteries but especially for automobile batteries. Any deep discharge of an automobile battery will af-

fect its capacity to store energy. Several deep discharges would result in a premature replacement of the battery. The charger then sits in "limbo" waiting for the normal operating range line voltage to reappear.

If the charger has:

- 1) an overheating condition, or
- 2) an overvoltage condition which would lead to an over heating condition;

then the charger will revert to a "shutdown" mode until conditions return to normal. Under normal conditions the SHUT-DOWN line (J2-2) is at 0.1-0.2 Vdc. When the charger reverts to the shutdown mode, J2-2 rises to around 2-3 VDC. The charger remains in shutdown until the condition is corrected.

WARNING

Extreme care must be exercised when using an automobile battery for backup emergency power. The automobile battery must not be installed in the base station cabinet because a buildup of acidic fumes during outgassing would damage the base station circuitry. Also, there could be a dangerous buildup of hydrogen gas in the cabinet during outgassing which could lead to an explosion. Even for an automobile battery correctly installed outside of the cabinet, there could be a dangerous concentration of hydrogen gas if the room is not properly ventilated. It may even be necessary to provide a "hood" over the battery and an exhaust system to vent the gas to the out-side world. Follow OSHA (or other equivalent agency) safety construction rules to determine a proper design.

CIRCUIT DESCRIPTION AND THEORY OF OPERATION FOR THE 344A3168P1 OR P2 BATTERY CHARGER

GENERAL

The 344A3168 battery charger has been designed to provide both system battery charging and relay switched, emergency power via automobile battery or gel cell battery for the MASTR II/IIE/MIII series of base stations.

The charger monitors system line voltage for possible interruptions. During normal operation, the charger maintains full charge on the emergency power battery by providing a trickle charge current. In the event of a power source interruption, the charger sets the STATUS line to the emergency power mode,

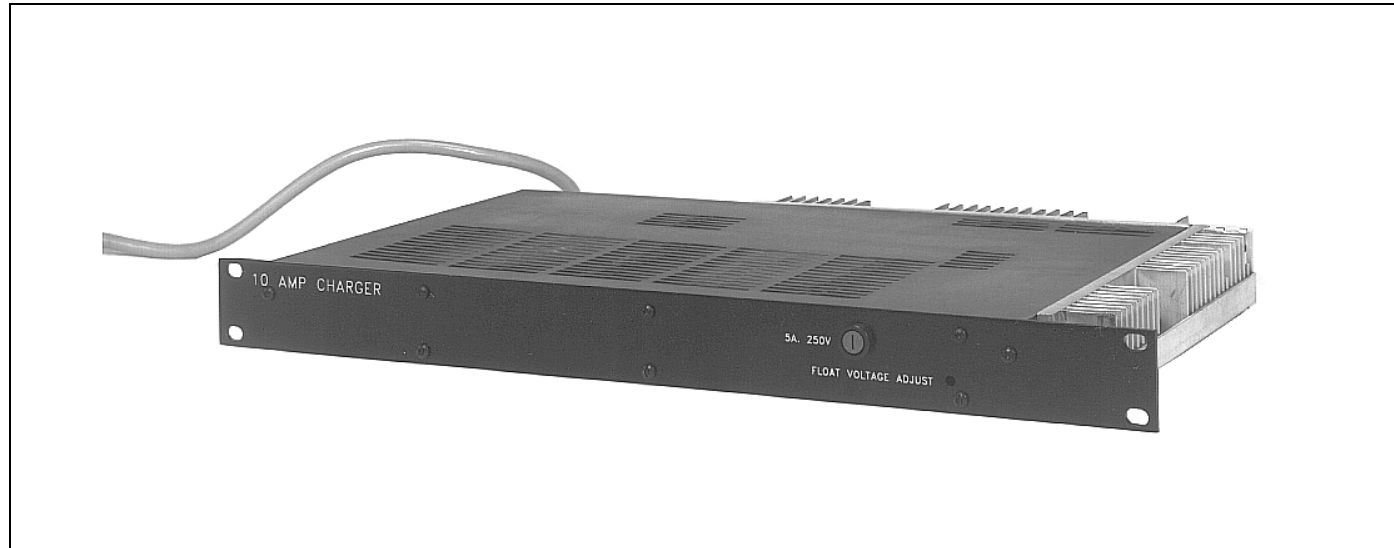

Figure 1 - 344A3168 Charger

Several general rules can be applied to estimate charge time of a lead acid battery system. There is almost a 100% conversion of electrical energy to stored chemical energy for the first 80% of battery capacity. If usable capacity is defined to be at least 80 % of full charge, then the time to reach usable capacity is: $T = 0.8 \times AH/C$, where T is in hours, AH is in amp-hours, and C is the average charge rate in amps. To charge the remaining 20 % to a full charge takes longer because the electrical energy is no longer close to 100 % conversion to stored chemical energy. The time to a full charge can be estimated as, $T = 1.1 \times AH/C$, where again T is in hours, AH is in amp-hours, and C is the average charge rate in amps. Using these estimates for a ten amp charger, a standard 55 Amp-Hour automobile battery and a gel cell system that uses four 25 Amp-Hour batteries in parallel would recharge in the following times:

Estimates can be provided for air time for a MII/MIII station. Assuming a worst case scenario of a 100% transmit duty cycle, the station air time with a 55 Amp-Hour automobile battery would be approximately one hour and considerably longer for a smaller transmit duty cycle. With a four-in-parallel 25 Amp-Hour gel cell system, the station air time for a 100% transmit duty cycle would be approximately three hours with again a correspondingly longer air time for a smaller transmit duty cycle.

Qty.	Type	Usable Capacity	Full Capacity
1	55 Amp-Hour Auto Battery	4.4 Hours	6.0 Hours
4	25 Amp-Hour Gel Cell Batteries	8.0 Hours	11.0 Hours

NOTE

With the four-in-parallel gel cell battery system, if one gel cell becomes defective before the other three, the customer can run with only three gel cells in parallel (with reduced air time, of course). It is not advisable to run with only two gel cells in parallel because of excessive charge current from the charger which would damage the gel cells. It is good practice when one gel cell battery becomes defective to replace all four gel cell batteries because of uneven charge and discharge characteristics of new versus old gel cells. For that same reason it is also advisable not to mix different brands of gel cells.

MAIN CHARGING CIRCUITRY

Power to the charging circuitry is provided from a 120 Vac, 60 Hz (P1) or 230 Vac/50 Hz (P2) line source connected to the main power cord (W801). Input power is passed through fuse F1 (and F2 for P2), which limits input current to 5 amps, and past varistor VR1. VR1 is a voltage transient surge protector which clamps the line at approximately 150 Vac (P1) or 275 Vac (P2). This protects the internal circuitry from potentially harmful line voltage surges.

Line voltage is then applied to transformers T1 and T2 which in parallel step the line voltage down to approximately 38 Vac. This voltage is then applied to rectifiers D1 and D2 as well as filter capacitors C1, C2, and C3. After rectification and filtering, the unregulated DC voltage is approximately 20 Vdc.

Charging current then flows through the linear regulator stage on its way to the battery. The linear regulator is composed of two basic groups. These groups are the series pass regulator group and the series pass control group.

The series pass regulator group consists of Q1, Q2, Q3, R1, R2, and R3. In order to control the output voltage of the charger, the series pass transistors are operated as variable resistors. If the load on the charger is increased, causing a drop in the output voltage, the resistance of the series pass transistors is automatically decreased. With a decrease in series pass resistance, less voltage is dropped across the transistors thus increasing the output voltage back to the desired value.

This implementation has one major drawback, a major percentage of the total power drawn by the charger is dissipated across the series pass transistors. In order to more effectively handle this dissipation, three transistors are used. Resistor R1, R2, and R3 provide negative feedback to the base of the appropriate transistor preventing unequal current flow and unequal power dissipation.

The series pass control circuitry is comprised of U3, Q4 and their associated bias resistors and decoupling capacitors. U3 continuously monitors the output voltage being developed by the interaction between the load and series pass transistors. When more output voltage is required to maintain regulation, U3 increases drive to transistor Q4. Q4 provides the amount of series pass transistor base drive necessary to decrease their resistance and boost the output voltage back up to the desired value.

This continuous interaction between the control circuitry and series pass state forms a closed loop control group which provides the regulated output voltage to the battery. Potentiometer R12 varies the amount of voltage feedback in the control loop thus allowing precise adjustment of the output voltage at which regulation is maintained.

OVERCURRENT PROTECTION

Overcurrent protection is provided via a current foldback scheme. Resistors R4, R5, and R6 form a current sensing element. The amount of voltage developed across these resistors is directly proportional to the amount of current flowing through them. This sense voltage is applied to the regulator control integrated circuit, U3, by means of R9, R10, and R50. As the current through these sense resistors increases above approximately 10.5 amps, the sense voltage and output current to decrease. This current foldback ap-

proach for overcurrent protection decreases the amount of power dissipated across the series pass transistors during a faulted condition. The maximum allowable short circuit current is less than 3 amps.

INPUT OVERVOLTAGE PROTECTION

Overvoltage protection circuitry is provided to protect the charger from abnormally high AC line voltages. These voltages could cause premature failure of the series pass transistors due to excessive power dissipation. When the line voltage exceeds the limits specified for normal operation, the charger senses an abnormal condition and reverts to the SHUTDOWN mode. The charging current to the battery is cut off by disabling the regulator control integrated circuit, U3.

AC line voltage is applied to the input of transformer T3 which then steps down the voltage. This voltage is then rectified and filtered into a DC voltage by D10 and C18. Resistor R27 sets the response time of the filter to decreasing line voltages. The resultant DC voltage is directly proportional to the value of AC line voltage being seen by the charging circuitry. The DC voltage is then divided by the series combination of R28, R29, and R30. Potentiometer R29 is used to adjust for transformer winding ratio tolerances from unit to unit and is factory set. Capacitor C14 provides addition filtering of the line sense voltage.

CAUTION

Potentiometer R29 is specifically adjusted per internal factory specs to set the proper trip voltages to send the charger into the SHUTDOWN mode if the limits are exceeded. With the line voltage and the line frequency set at nominal values, R29 is adjusted for 3.24 ± 0.02 V(@ 230 Vac 50Hz) or 3.20 ± 0.02 Vdc (@ 121 Vac 60 Hz) at TP1. AN IMPROPER TUNING OF R29 COULD CAUSE THE CHARGER'S PASS TRANSISTORS TO DISSIPATE EXCESSIVE HEAT, RESULTING IN LOWERED RELIABILITY. THERE SHOULD BE NO NEED TO ADJUST R29 IN THE FIELD.

The same sense voltage signal provides information for both the overvoltage and undervoltage sensing circuitry. U8A provides current buffering to eliminate degradation of the signal. This buffered signal is then applied to the overvoltage comparator U7B. When a line overvoltage condition is sensed, the output of U7B, normally a high impedance, becomes a very low impedance. This low impedance removes base drive to transistor Q7. When Q7 loses base drive it turns off allowing the shutdown pin of U3 to go high and disabling drive to the series pass transistors. This effectively turns off all charging current to the battery.

Charger overvoltage sensing depends on whether the charger is in the trickle or full charge mode. The first mode of operation is for a trickle charge condition in which the battery charging current is less than 200 milliamps. The allowable line voltage range for this mode of operation is $\pm 20\%$ (P1) or $\pm 15\%$ (P2). The second mode of operation is for charging of the battery at current up to the maximum output current of 10 amps. The line voltage tolerance range for this mode of operation is $\pm 10\%$. It is critical for the charger to be able to operate over both ranges yet protect itself from excessive series pass transistor heat dissipation.

The method by which the charger discerns the appropriate line voltage tolerance is by monitoring the amount of charging current flowing through the current sense resistors R4, R5, and R6. The current sense voltage developed across these resistors is applied across the differential amplifier of U8B. The output of U8B is normally biased at 2.5 Vdc. However, as the amount of current through the sense resistors increases, (sense voltage increases) the output of U8B begins to decrease. At approximately 6 amps of charging current, the output of U8B is low enough to trip the output of comparator U6B. This normally low impedance output goes to a high impedance state removing resistor R41 from its parallel placement with resistor R40. With R40 removed, the line voltage sense voltage is now only divided by the series combination of resistors R38 and R40. This decreases the amount of line sense voltage needed to trip the overvoltage comparator U7B. This sets up the $\pm 10\%$ line voltage tolerance range. When the charging current is less than 6 amps, the output of comparator U6B remains a low impedance, placing R41 in parallel with R40 and setting up the $\pm 20\%$ ($\pm 15\%$) line voltage tolerance.

OVERTEMPERATURE PROTECTION

To protect the charger from abnormal ambient temperature operating conditions it is equipped with overtemperature protection. A thermostat, S1, has been attached to the heat sink in order to monitor the operating temperature of the series pass transistors. This thermostat is normally closed. When an abnormal operating temperature is reached, the thermostat's switch contacts open and remove base drive to Q7. As described earlier, removing base drive to Q7 causes shutdown of the charging regulator. When the temperature of the heat sink returns to a safe value, the contacts of S1 close and operation resumes.

BATTERY SWITCHING OPERATION

When the AC line voltage drops below 70% of nominal voltage, the charger interrupts the charging mode of operation and switches the battery on line for emergency power operation. The AC line voltage is sensed as described under overvoltage protection. The U8A buffered sense voltage is

applied to undervoltage comparator U7A. When the sense voltage drops below the specified limit, the normally low impedance output of U7A switches to a high impedance state. This interrupts base drive current being sourced from transistor Q5. With the interruption of its base drive current, Q5 shuts off removing the 24 volt signal coming from U4.

Switching transistor Q5 off also removes drive to relay K1 and K3. With removal of relay drive the contacts associated with K1 and K3 switch to their normally closed states. When this happens, battery charging current can no longer flow through K1 to the battery. With the K1 relay contacts in their normally closed position, current flows from the battery through K2 to the system. In addition, the K3 relay contacts open thus isolating the switched ground signal from ground.

DEEP DISCHARGE PROTECTION

The battery voltage is sensed at the charger's A + port. This voltage provides both bias voltage and signal input to voltage comparator U6A. The battery voltage is stepped down by resistors R20 and R21 and compared with the 2.5 Vdc output of voltage reference U5. When the base station reverts to emergency power, the fully charged battery voltage starts at around 12.7 Vdc and slowly drops as the battery discharges. The output of U6A remains an open circuit, allowing pull up resistors R24 and R26 to provide drive to Q6 to energize relay K2. When the battery has discharged to around 10.5 Vdc the voltage comparator output pulls low, disabling the drive to Q6 and de-energizing K2. The charger and base station remain "in limbo" until the line voltage is restored to the station power supply and charger. The charger A + port must be greater than 12.25 Vdc before K2 is re-energized to await the next emergency power state.

NOTE

The first 344A3168P1, Rev. 0 chargers do not have reverse polarity protection designed into the circuitry. This may allow blowing at transistor Q6 if customers accidentally reverse the battery cable leads. This prevents the charger from properly switching relay K2 for emergency power. A production change on 344A3168P1, Rev. A chargers and all 344A3168P2 chargers adds a diode similar to a 1N4004 to the collector of Q6. Contact Com-Net Ericsson Technical Support for any additional information.

ERROR FLAG SIGNALS

In the event of abnormal system operation, the charger provides two error flag signals as output to the system controller. The first, SHUTDOWN, is an indication of emergency power operation. During normal operation from AC

line voltage the 24 volt signal from transistor Q5 is present at connector J2-1. When the system is in the emergency power mode, this signal is removed and becomes a high impedance, greater than one Megohm.

The second error flag is provided at connector J2-2. This signal, SHUTDOWN, indicates whether the charger is operating normally or has been shutdown due to excessive operating temperature or high line voltage. During normal operation, the 24 VDC output of voltage regulator U4 is applied through R15 to and U3. Due to the U3 interface, this voltage becomes approximately 3 volts. This signal is independent of transistor Q5. During shutdown of the charger, this output is pulled down by transistor Q7 becoming an active low impedance signal. With removal of the shutdown conditions, this signal automatically returns to the normal operating state.

INTERNAL BIAS VOLTAGE SOURCES

There are three internal bias voltage sources implemented within the charger to provide internal housekeeping supply voltages and references. The first is the previously mentioned 24 volt source provided by voltage regulator U4. This source is supplied directly off the AC line via transformer T1 and T2 as well as rectifier D6 and filter C10. This source supplies power for regulator control integrated circuit U3, relays K1, K2 and also the error flag output signal.

The second source is provided by linear regulator U1. This regulator supplies power for all the additional control circuitry. It also acts as a buffer between the control circuitry and the unregulated charging voltage from which it draws its own power. Voltage excursions on the charging bliss are not transmitted to the control circuitry thus insuring the charger's ability to protect itself.

Lastly, is the precision voltage reference provided by regulator U2. This precision 2.5 volt source creates the reference

voltage that is used by all the AC line voltage comparators. The ability to hold reasonable tolerances on line voltage sense point requires the use of a high tolerance reference voltage.

FLOAT VOLTAGE ADJUST

Both the automobile batteries and gel cells used with the new charger are lead acid based batteries. The chemical reaction rates for converting the electrical energy to stored chemical energy during charging are functions of temperature. Nominally either battery should be seeing a float voltage of 13.6 Vdc when the ambient temperature of the battery is 77°F (25° C). As the temperature increases past nominal room temperature the chemical reaction rates increase past nominal and the float voltage should be lowered to compensate. Conversely, the float voltage should be increased if the batteries are to see an average temperature of less than 77°F, but the float voltage should never exceed 14.4 Vdc. For a nominal 12 Vdc, 6 cell, lead acid battery the slope of float voltage versus ambient temperature is around $-18 \text{ mV}/^\circ\text{F}$ ($-32.4 \text{ mV}/^\circ\text{C}$).

By use of the proper float voltage optimum battery usage can be obtained. If the float voltage is set too high, the battery can be overcharged, resulting in outgassing and reduction in lifetime of the battery. If the float voltage is set too low the battery recharges at a slower rate but more importantly the battery will permanently lose some of its storage capacity. Most manufacturers recommend a float voltage between 13.5 and 13.8 Vdc at room temperature.

The factory has preset the float voltage for 13.6 Vdc. If the battery will be in an environment where the AVERAGE ambient temperature will not be 77°F, then the option exists to adjust the FLOAT VOLTAGE ADJUST pot for optimum float voltage. Cable W1 (19B801937P3) is removed from J1 of charger 344A3168 to present an open circuit load. A high impedance DC voltmeter is attached to -1 (A+) and J1-2 (A-) and the pot adjusted for optimum float voltage.

TROUBLESHOOTING PROCEDURE

SYMPTOM	PROCEDURE
NO CHARGING OUTPUT VOLTAGE	CHECK THE FOLLOWING: PROPER LINE VOLTAGE OPEN FUSE F1 OPEN TRANSISTOR A1Q4 BAD I.C. A1U3 SHORTED A1Q7 OPEN THERMISTOR A2S1 BAD RELAY A1K1 BAD I.C. A1U4 BAD I.C. A1U7
OUTPUT VOLTAGE TOO HIGH (GREATER THAN 14 Vdc)	CHECK THE FOLLOWING: SHORTED TRANSISTOR A2Q1 SHORTED TRANSISTOR A2Q2 SHORTED TRANSISTOR A2Q3 BAD POTENTIOMETER A1R12 BAD I.C. A1U7
OUTPUT VOLTAGE TOO LOW (GREATER THAN 1 Vdc LESS THAN 13.6 Vdc)	CHECK THE FOLLOWING: LOAD TOO HIGH (IN FOLDBACK) BAD POTENTIOMETER A1R12 BAD I.C. A1U3 SHORTED A1C4
BLOWN FUSE F1	CHECK THE FOLLOWING: SHORTED VARISTOR A1RV1 SHORTED TRANSFORMER T1 SHORTED TRANSFORMER T2 SHORTED TRANSFORMER A1T3 SHORTED DIODE A1D1 SHORTED DIODE A1D2 SHORTED DIODE A1D6 SHORTED DIODE A1D10 SHORTED CAPACITOR A1C1 SHORTED CAPACITOR A1C2 SHORTED CAPACITOR A1C3 SHORTED CAPACITOR A1C10 SHORTED CAPACITOR A1C18
BATTERY NOT SWITCHING TO SYSTEM BACKUP	CHECK THE FOLLOWING: BAD RELAY A1K1 BAD RELAY A1K2 OPEN TRANSISTOR A1Q6 BAD I.C. U5 BAD I.C. U6 SHORTED TRANSISTOR A1Q5
STATUS ERROR FLAG NOT PRESENT	CHECK THE FOLLOWING: LINE VOLTAGE TOO LOW OPEN TRANSISTOR A1Q5 BAD I.C. A1U4 BAD I.C. A1U7 OPEN DIODE A1D9
SWITCHED GROUND NOT CONNECTED	CHECK THE FOLLOWING: LINE VOLTAGE TOO LOW BAD RELAY A1K3 OPEN TRANSISTOR A1Q5 BAD I.C. A1U4
ANY OTHER FAULT	CONSULT THE FACTORY

BATTERY AND HARDWARE KITS

SYMBOL	PART NO.	DESCRIPTION
		MIII AUTOMOBILE BATTERY KIT 344A3696G1
W1	19B801937P4	Power Cable
W2	19B801970P1	Power Cable
W3		
W4	19B801970P3	Power Cable
W5	19B801970P4	Power Cable
W6		Not Used
W7		Not Used
W8		Not Used
1	344A3450G1	Hardware Kit
2		Not Used
3		Not Used
4		Not Used
		MIII GEL CELL BATTERY KIT 344A3696G2
W1	19B801937P4	Power Cable
W2	19B801970P1	Power Cable
W3		Not Used
W4		Not Used
W5		Not Used
W6	19B801970P5	Power Cable
W7	19B801970P6	Power Cable
W8	19C327801G1	Harness
1		Not Used
2	344A3450G5	Hardware Kit
3	19B802073P1	Rear support
4	19B802067P1	Cover
		HARDWARE KIT 344A3450G1
1	7160861P33	SPRING NUT
2	19A134011P2	SCREW
3	7160861P4	SPRING NUT
4	N145P1507B6	TAPPED SCREW
		HARDWARE KIT 344A3450G5
1	7160861P33	SPRING NUT
2	19A134011P2	SCREW
15	N403P16B6	LOCK WASHER
17	N80P16008B6	MACHINE SCREW
18	N403P19B6	LOCK WASHER
19	N402P39B6	FLAT WASHER
20	N80P15012B6	MACHINE SCREW
21	N402P38B6	FLAT WASHER

*COMPONENTS, ADDED, DELETED OR CHANGED BY PRODUCTION CHANGES

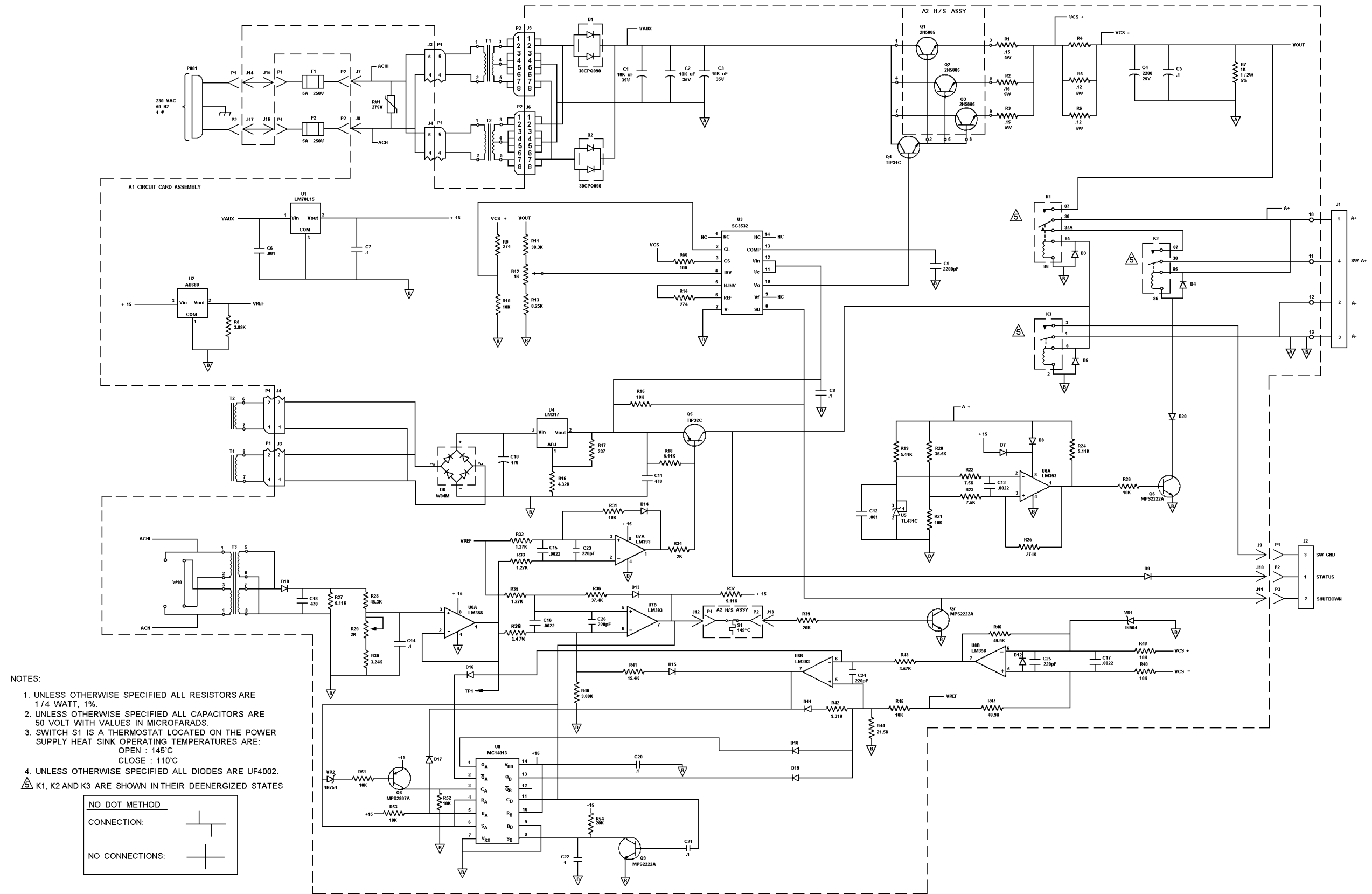

- NOTES:
1. UNLESS OTHERWISE SPECIFIED ALL RESISTORS ARE 1/4 WATT, 1%.
 2. UNLESS OTHERWISE SPECIFIED ALL CAPACITORS ARE 50 VOLT WITH VALUES IN MICROFARADS.
 3. SWITCH S1 IS A THERMOSTAT LOCATED ON THE POWER SUPPLY HEAT SINK OPERATING TEMPERATURES ARE:
OPEN : 145°C
CLOSE : 110°C
 4. UNLESS OTHERWISE SPECIFIED ALL DIODES ARE UF4002.
- △ K1, K2 AND K3 ARE SHOWN IN THEIR DEENERGIZED STATES

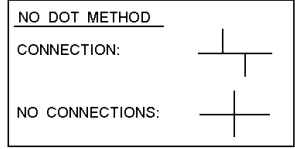

50 Hz CHARGER
344A3168P2

(289PS10, Rev. A)

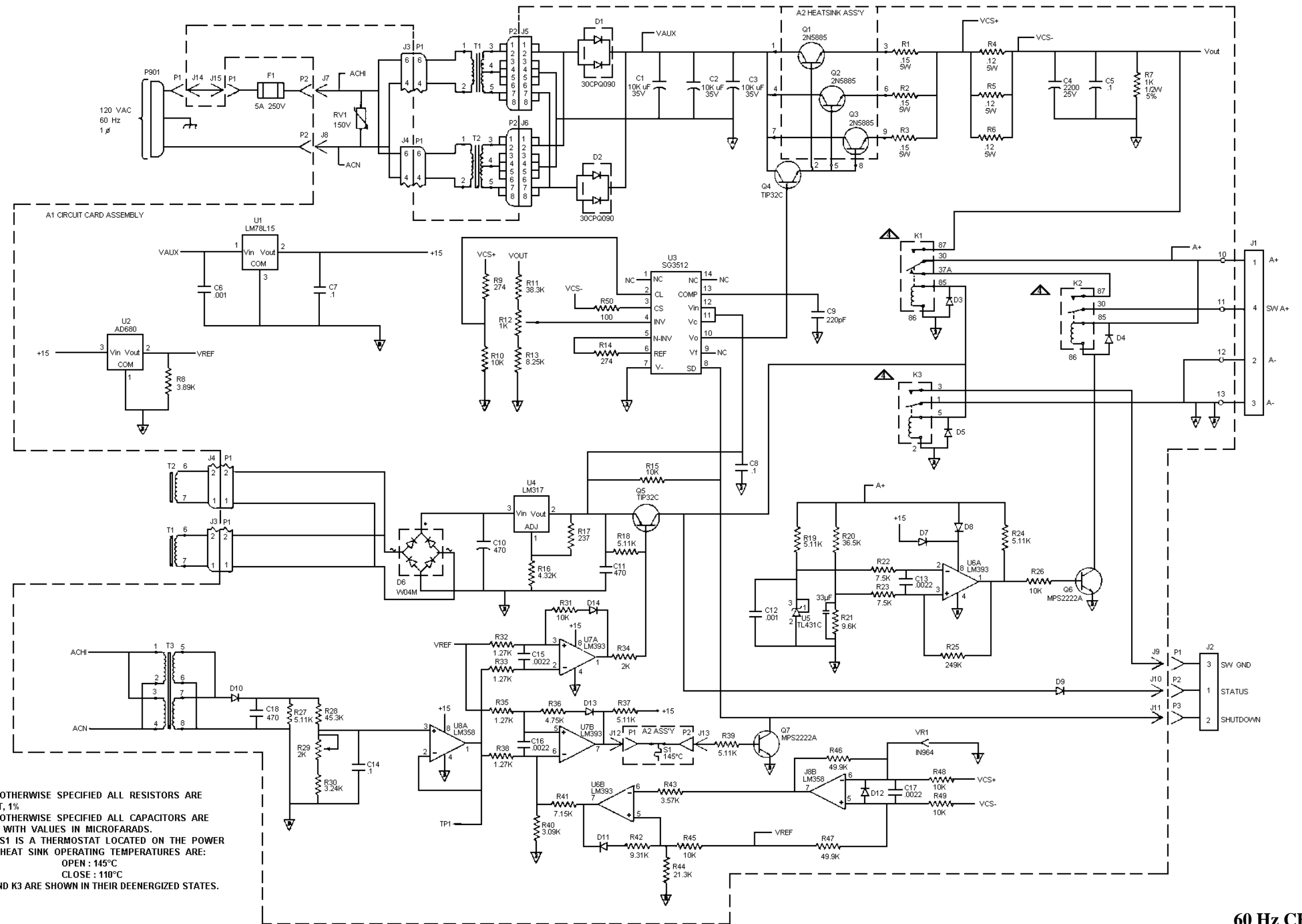

- NOTES:
- UNLESS OTHERWISE SPECIFIED ALL RESISTORS ARE 1/4 WATT, 1%.
 - UNLESS OTHERWISE SPECIFIED ALL CAPACITORS ARE 50 VOLT WITH VALUES IN MICROFARADS.
 - SWITCH S1 IS A THERMOSTAT LOCATED ON THE POWER SUPPLY HEAT SINK OPERATING TEMPERATURES ARE:
OPEN : 145°C
CLOSE : 110°C
- ▲ K1, K2 AND K3 ARE SHOWN IN THEIR DEENERGIZED STATES.

60 Hz CHARGER
344A3168P1

REF DES	CEN. TO CEN/ LEADFORM #	ITEM NO
R1	-	15
R2	-	15
R3	-	15
R4	-	14
R5	-	14
R6	-	14
R12	-	12
R29	-	13
C1	-	18
C2	-	18
C3	-	18
C4	92038500	17
C10	-	16
C11	-	16
C18	-	16
K1	-	9
K2	-	10
K3	-	11
T3	-	8
D6	92038300	19
RV1	-	23
Q5	92038000	20
Q6	92037800	21
Q7	92037800	21
Q8	92037700	22
Q9	92037800	21

REF DES	CEN. TO CEN/ LEADFORM #	ITEM NO
U1	-	25
U2	-	26
U3	-	27
U5	-	28
U6	-	29
U7	-	29
U8	-	30
U9	-	24
J3	-	31
J4	-	31
J5	-	32
J6	-	32
J7	-	33
J8	-	33
J9	-	33
J10	-	33
J11	-	33
J12	-	33
J13	-	33
J14	-	33
J15	-	33
J16	-	33
J17	-	33
TP1	-	33

QTY	ITEM NO	PART NUMBER	DESCRIPTION	NOTES
4	35		NUT, KEEPER, #10	
4	34		STUD, PEM, #10-32	
12	33		CONNECTOR, FASTON	
2	32		CONNECTOR, HEADER, 8 PIN (J5, J6)	
2	31		CONNECTOR, HEADER, 6 PIN (J3, J4)	
1	30		INT. CKT, LM358	
2	29		INT. CKT, LM393	
1	28		INT. CKT, TL431	
1	27		INT. CKT, SG3532	
1	26		INT. CKT, AD680	
1	25		INT. CKT, 78L15	
1	24		INT. CKT, MC4013	
1	23		VARISTOR, 275V	
1	22		TRANSISTOR, MFS2907A	
3	21		TRANSISTOR, MFS2222A	
1	20		TRANSISTOR, TIP32C	
1	19		BRIDGE RECTIFIER	
3	18		CAPACITOR, 10,000 UF, 35V	
1	17		CAPACITOR, 2200 UF, 25V	
3	16		CAPACITOR, 470 UF, 50V	
3	15		RESISTOR, .15 OHM, 5 W, 1%	
3	14		RESISTOR, .12 OHM, 5 W, 1%	
1	13		RESISTOR, POTENTIOMETER, 2.0 K OHM	
1	12		RESISTOR, POTENTIOMETER, 1.0 K OHM	
1	11		RELAY, SPDT, 24 V / 5 A	
1	10		RELAY, SPDT, 12 V / 30 A	
1	9		RELAY, SPDT, 24 V / 30 A	
1	8		TRANSFORMER	4
3	7		LEADWIRE ASSEMBLY (W2, W5, W8)	
3	6		LEADWIRE ASSEMBLY (W1, W4, W7)	
3	5		LEADWIRE ASSEMBLY (W3, W6, W9)	
1	4		HEATSINK ASSEMBLY (Q4)	
1	3		HEATSINK ASSEMBLY (U4)	
2	2		HEATSINK ASSEMBLY (D1, D2)	
1	1		PWB AUTOINSERT ASSEMBLY, A1	2

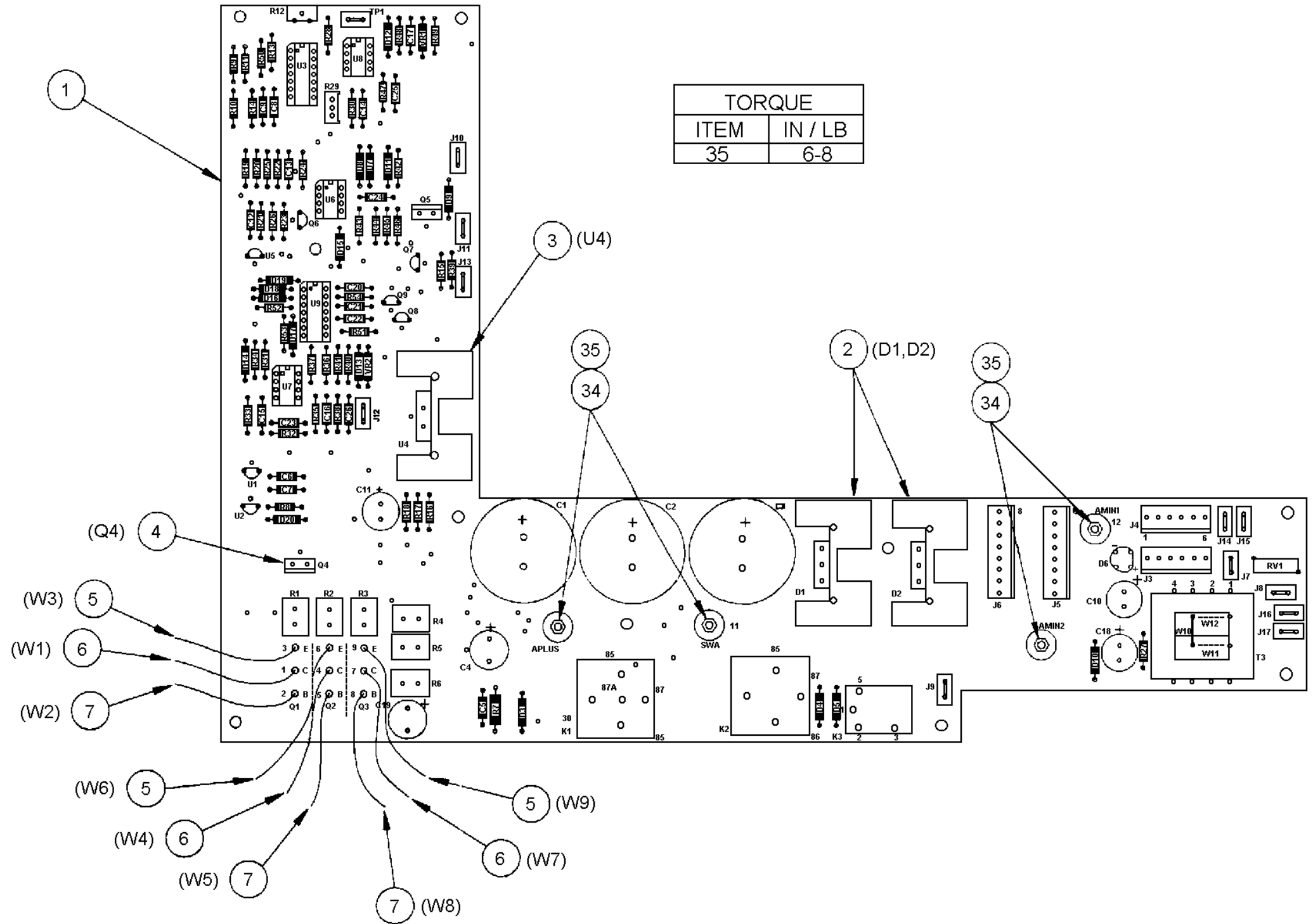

50 Hz CHARGER BOARD ASSEMBLY
M29/91040000

(91040000, Rev. H)

NOTES:

- 1 ITEM (21) IS USED TO ATTACH ITEM (2) TO ITEM (10) AND (11) ONLY.
- 2 ITEM (20) IS USED TO ATTACH ITEM (11) AND (12) TO ITEM (10) ONLY.
- 3 ITEM (20) TO BE INSTALLED AFTER ITEM (9).

ITEM	TORQUE IN/LBS
20, 21	6 - 8 (M3.5)
23	6 - 8 (#6 - 32)
24	14 - 16 (#8 - 32)
25	17 - 20 (#10 - 32)
22	6 - 8 (#4 - 40)

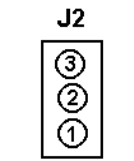
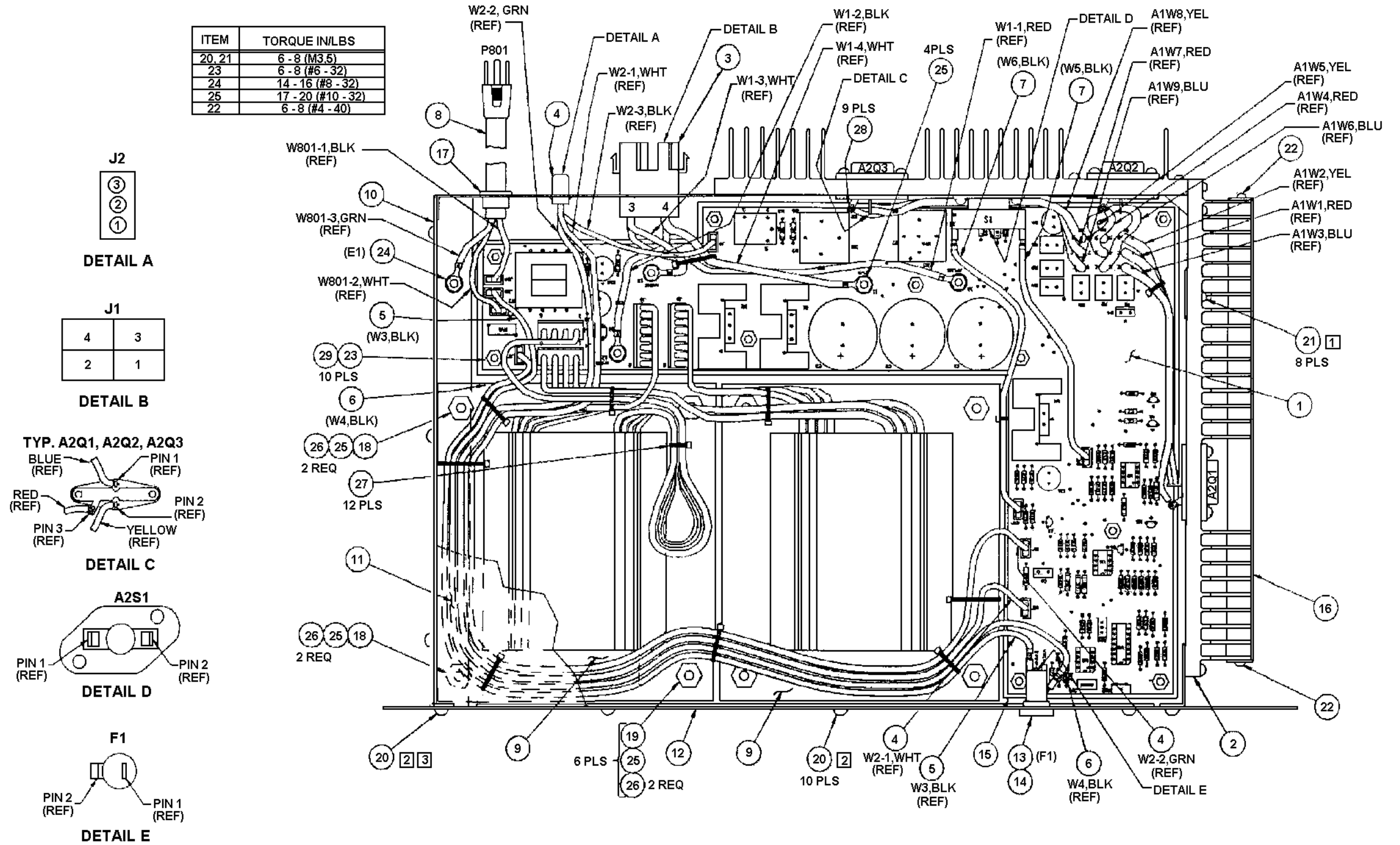

DETAIL A

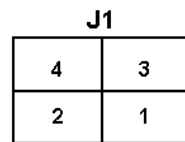

DETAIL B

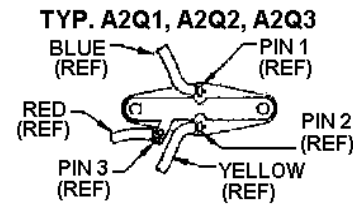

DETAIL C

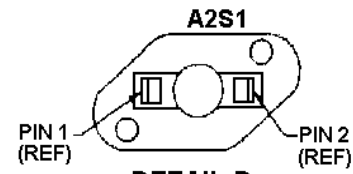

DETAIL D

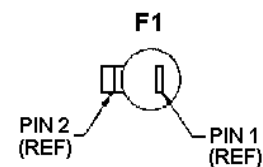

DETAIL E

**BATTERY CHARGER
344A3168P1 & P2
ISSUE 3**

SYMBOL	PART NO.	DESCRIPTION
Battery Charger Top Assembly		
PS5A1	M29/91035300	Printed Circuit Card Assembly.
PS5A2	M29/91037100	Power Transistor Heat Sink Assembly.
PS5W1	M29/25011200	J1 Output Power Conn. Harness Assembly.
PS5W2	M29/25011300	J2 Test Connector Harness Assembly.
PSW801	M29/11022301	AC Cord Set.
PS5T1	M29/289P1	Main Power Transformer.
PS5T2	M29/289P1	Main Power Transformer.
	M29/7064200	Chassis.
	M29/7064300	Top Cover.
	M29/7064400	Front Panel.
	M29/9014200	Fuse Holder.
	M29/9013900	Fuse, Bussman, MDL-5.
	M29/31023000	Insulator, PWB To Chassis.
	M29/11022000	Strain Relief, HEYCO, 1200.
	M29/7064700	Heat Sink Skid.
	M29/11024500	Cable Tie.
	M29/22045900	Spacer, #10 X .375, Nylon.
	M29/22046000	Spacer, #10 X .125, Nylon.
	M29/22046401	Screw, M3-5 X .500, TORX Head.
	M29/22046400	Screw, M3-5 X 390, TORX Head.
	M29/22028900	Screw, #4-40 X .375, HEX Head, Thd. Rolling.
	M29/22046000	Washer, Shoulder, #10.
	M29/22041501	Nut, #6-32, Keeper, 1/8 Thk.
	M29/22041502	Nut, #8-32, Keeper, 1/8 Thk.
	M29/22041503	Nut, #10-32, Keeper, 1/8 Thk.
Printed Circuit Card Assembly PS5A1 M29/91035300		
C1	M29/17033400	Capacitor, 10,000 µF, 35 V., Electrolytic.
C2	M29/17033400	Capacitor, 10,000 µF, 35 V., Electrolytic.
C3	M29/17033400	Capacitor, 10,000 µF, 35 V., Electrolytic.
C4	M29/17031901	Capacitor, 2,200 µF, 25 V., Electrolytic.
C5	M29/17018100	Capacitor, 0.1 µF, 50 V., Ceramic.
C6	M29/17018107	Capacitor, .001 µF, 100 V., Ceramic.
C7	M29/17018100	Capacitor, 0.1 µF, 50 V., Ceramic.
C8	M29/17018100	Capacitor, 0.1 µF, 50 V., Ceramic.
C9	M29/17018107	Capacitor, .001 µF, 100 V., Ceramic.
C10	M29/17016202	Capacitor, 470 µF, 50 V., Electrolytic.
C11	M29/17016202	Capacitor, 470 µF, 50 V., Electrolytic.
C12	M29/17018107	Capacitor, .001 µF, 100 V., Ceramic.
C13	M29/17018214	Capacitor, .0022 µF, 100 V., Ceramic.
C14	M29/17018100	Capacitor, 0.1 µF, 50 V., Ceramic.
C15	M29/17018214	Capacitor, .0022 µF, 100 V., Ceramic.
C16	M29/17018214	Capacitor, .0022 µF, 100 V., Ceramic.
C17	M29/17018214	Capacitor, .0022 µF, 100 V., Ceramic.
C18	M29/17016202 19A703314P3	Capacitor, 470 µF, 50 V., Electrolytic. Electrolytic: .33µF, 16 VDCW (Install across R21).
D1	M29/18027200	Rectifier, Dual Gen. Instruments, 30CPQ000.

SYMBOL	PART NO.	DESCRIPTION
D2	M29/18027200	Rectifier, Dual Gen. Instrument., 30CPQ090.
D3	M29/18018004	Rectifier, General Purpose, UF4002.
D4	M29/18018004	Rectifier, General Purpose, UF4002.
D5	M29/18018004	Rectifier, General Purpose, UF4002.
D6	M29/19007500	Rectifier Bridge, Gen. Instrument., W04M.
D7	M29/18018004	Rectifier, General Purpose, UF4002.
D8	M29/18018004	Rectifier, General Purpose, UF4002.
D9	M29/18018004	Rectifier, General Purpose, UF4002.
D10	M29/18018004	Rectifier, General Purpose, UF4002.
D11	M29/18018004	Rectifier, General Purpose, UF4002.
D12	M29/18018004	Rectifier, General Purpose, UF4002.
D13	M29/18018004	Rectifier, General Purpose, UF4002.
D14	M29/13048104	Rectifier, General Purpose, UF4002.
J1	M29/13048100	Connector, Faston Tab, Amp, 62650-1.
J2	M29/13048100	Connector, Faston Tab, Amp, 62650-1.
J3	M29/40024401	Connector, 6 Pos., Amp, 640445-6.
J4	M29/40024401	Connector, 6 Pos., Amp, 640445-6.
J5	M29/40024402	Connector, 8 Pos., Amp, 640445-8.
J6	M29/40024402	Connector, 8 Pos., Amp, 640445-8.
J7	M29/13048100	Connector, Faston Tab, Amp, 62650-1.
J8	M29/13048100	Connector, Faston Tab, Amp, 62650-1.
J9	M29/13048100	Connector, Faston Tab, Amp, 62650-1.
J10	M29/13048100	Connector, Faston Tab, Amp, 62650-1.
J11	M29/13048100	Connector, Faston Tab, Amp, 62650-1.
J12	M29/13048100	Connector, Faston Tab, Amp, 62650-1.
J13	M29/13048100	Connector, Faston Tab, Amp, 62650-1.
J14	M29/13048100	Connector, Faston Tab, Amp, 62650-1.
J15	M29/13048100	Connector, Faston Tab, Amp, 62650-1.
K1	M29/20003700	Relay, 12 V., 40 A., SPDT, P&B, VF4-15H13.
K2	M29/20004000	Relay, 12 V., 40 A., SPST, AROMAT, CB1AF-P-12V.
K3	M29/20003600	Relay, 12 V., 5 A., SPST, AROMAT, JS1AE-DC24V.
Q1	M29/18030800	Transistor, Power, NPN, 2N5885.
Q2	M29/18030800	Transistor, Power, NPN, 2N5885.
Q3	M29/18030800	Transistor, Power, NPN, 2N5885.
Q4	M29/18017600	Transistor, Power, NPN, TIP31C.
Q5	M29/18023500	Transistor, Power, PNP, TIP32C.
Q6	M29/18023200	Transistor, Gen. Purpose, NPN, MPS2222A.
Q7	M29/18023200	Transistor, Gen. Purpose, NPN, M352222A.
R1	M29/16013001	Resistor, 0.15, 5 W., 1%, Ceramic Wire Wound.
R2	M29/16013001	Resistor, 0.15, SW., 1%, Ceramic Wire Wound.
R3	M29/16013001	Resistor, 0.15, 5 W., 1%, Ceramic Wire Wound.
R4	M29/16013900	Resistor, 0.12, 5 W., 1%, Ceramic Wire Wound.
R5	M29/16013900	Resistor, 0.12, 5 W., 1%, Ceramic Wire Wound.
R6	M29/16013900	Resistor, 0.12, 5 W., 1%, Ceramic Wire Wound.
R7	M29/16001573	Resistor, 1K, 1/2 W., 5%, Carbon Film.
R8	M29/16001464	Resistor, 3.09K, 1/4 W., 1%, Metal Film.
R9	M29/16001456	Resistor, 274, 1/4 W., 1%, Metal Film.
R10	M29/16001525	Resistor, 10K, 1/4 W., 1%, Metal Film.
R11	M29/16001448	Resistor, 38.3K, 1/4 W., 1%, Metal Film.
R12	M29/16013500	Potentiometer, 1K, 1 Turn, Cermet.
R13	M29/160011449	Resistor, 8.25K, 1/4 W., 1%, Metal Film.
R14	M29/160011456	Resistor, 274, 1/4 W., 1%, Metal Film.
R15	M29/16001525	Resistor, 10K, 1/4 w., 1%, Metal Film.
R16	M29/16001447	Resistor, 4.32K, 1/4 W., 1%, Metal Film.

SYMBOL	PART NO.	DESCRIPTION
R17	M29/16001459	Resistor, 237, 1/4 W., 1%, Metal Film.
R18	M29/16001595	Resistor, 5.11K, 1/4 W., 1%, Metal Film.
R19	M29/16001595	Resistor, 5.11K, 1/4 W., 1%, Metal Film.
R20	M29/16001458	Resistor, 56.5K, 1/4 W., 1%, Metal Film.
R21	19A701250P296	Resistor, 9.76K, 1/4 W., 1%, Metal Film.
R22	M29/16001577	Resistor, 7.5K, 1/4 W., 1%, Metal Film.
R23	M29/16001577	Resistor, 7.5K, 1/4 W., 1%, Metal Film.
R24	M29/16001595	Resistor, 5.1K, 1/4 W., 1%, Metal Film.
R25	19A701250P439	Resistor, 249K, 1/4 W., 1%, Metal Film.
R26	M29/16001525	Resistor, 10K, 1/4 W., 1%, Metal Film.
R27	M29/16001595	Resistor, 5.11K, 1/4 W., 1%, Metal Film.
R28	M29/16001446	Resistor, 45.3K, 1/4 W., 1%, Metal Film.
R29	M29/16007503	Potentiometer, 2K, 10 Turn, Cermet.
R30	M29/16001477	Resistor, 3.24K, 1/4 W., 1%, Metal Film.
R31	M29/16001525	Resistor, 10K, 1/4 W., 1%, Metal Film.
R32	M29/16001591	Resistor, 1.27K, 1/4 W., 1%, Metal Film.
R33	M29/16001591	Resistor, 1.27K, 1/4 W., 1%, Metal Film.
R34	M29/16001599	Resistor, 2.00K, 1/4 W., 1%, Metal Film.
R35	M29/16001591	Resistor, 1.27K, 1/4 W., 1%, Metal Film.
R36	M29/16001590	Resistor, 4.75K, 1/4 W., 1%, Metal Film.
R37	M29/16001595	Resistor, 5.11K, 1/4 W., 1%, Metal Film.
R38	M29/16001591	Resistor, 1.27K, 1/4 W., 1%, Metal Film.
R39	M29/16001595	Resistor, 5.11K, 1/4 W., 1%, Metal Film.
R40	M29/16001478	Resistor, 3.09K, 1/4 W., 1%, Metal Film.
R41	M29/16001479	Resistor, 7.15K, 1/4 W., 1%, Metal Film.
R42	M29/16001470	Resistor, 9.31K, 1/4 W., 1%, Metal Film.
R43	M29/16001464	Resistor, 3.57K, 1/4 W., 1%, Metal Film.
R44	M29/16001471	Resistor, 21.3K, 1/4 W., 1%, Metal Film.
R45	M29/16001525	Resistor, 10K, 1/4 W., 1%, Metal Film.
R46	M29/16001582	Resistor, 49.9K, 1/4 W., 1%, Metal Film.
R47	M29/16001582	Resistor, 49.9K, 1/4 W., 1%, Metal Film.
R48	M29/16001525	Resistor, 10K, 1/4 W., 1%, Metal Film.
R49	M29/16001525	Resistor, 10K, 1/4 W., 1%, Metal Film.
R50	M29/16001526	Resistor, 100, 1/4 W., 1%, Metal Film.
RV1	M29/18008013	Metal Oxide Variator, 150 V., GE, V150LA20A.
T1	M29/FS56-020	Transformer.
U1	M29/19005701	Int. Circuit, Voltage Regulator, LM78L15.
U2	M29/19010500	Int. Circuit, Reference Voltage, AD680.
U3	M29/19009900	Int. Circuit, Lin, Reg. Controller, SG3532.
U4	M29/19002101	Int. Circuit, Voltage Regulator, LM317.
U5	M29/19009100	Int. Circuit, Voltage Reference, TL431C.
U6	M29/19010000	Int. Circuit, Dual Comparator, LM393.
U7	M29/19010000	Int. Circuit, Dual Comparator, LM393.
U8	M29/19006000	Int. Circuit, Dual Operational Amp., LM358.
VR1	M29/18001443	Zener Diode, 13 V., 1N964B.
	M29/33019700	Printed Circuit Card.
	M29/11023500	Heat Sink, Thermalloy.
	M29/11022400	Heat Sink.
	M29/31016703	Thermal Pad.
	M29/22027710	Screw, #44-40 X .500, HEX Head, Zinc Plated.
	M29/22041500	Nut, #4-40, Keeper, 1/8 Thk.
	M29/22041503	Nut, #10-32, Keeper, 1/8 Thk.
	M29/22045500	Stud, Perm, #10-32 X .500.
	M29/13040200	Terminal Wire, Amp, 640311-1.

SYMBOL	PART NO.	DESCRIPTION
	M29/27185266	Wire, 18 AWG, Blue, UL1452BL.
	M29/27185222	Wire, 18 AWG, Red, UL1452RD.
	M29/27185244	Wire, 18 AWG, Yellow, UL1452YL.
Power Transistor Heat Sink Assembly PS5A2 M29/91037100		
Q1	M29/18030800	Transistor, Power, NPN, 2N5885.
Q2	M29/18030800	Transistor, Power, NPN, 2N5885.
Q3	M29/18030800	Transistor, Power, NPN, 2N5885.
S1	M29/9016700	Thermostat, SPST, Norm. Closed.
	M29/11024700	Heat Sink.
	M29/11024800	Heat Sink.
	M29/11025000	Corner Block.
	M29/31023200	Thermal Pad.
	M29/13051800	Socket, TO-3.
	M29/7062500	Cover, TO-3.
	M29/22040000	Screw, #6-32 X .250, Pan Head, Zinc Plated.
	M29/22009008	Screw, #6-32 X .500, Pan Head, Zinc Plated.
	M29/22009007	Screw, #6-32 X .625, Pan Head, Zinc Plated.
J1 Output Conn. Harness Assembly PS5W1 M29/25011200		
J1	M29/40028600	Connector, 4 Pos., Amp, 641685-2.
	M29/13052600	Terminal, Connector, Amp, 350650-1.
	M29/13053900	Terminal, Ring, Amp, 52263.
	M29/26080499	Wire, 8 AWG, White, UL1028WH.
	M29/26080400	Wire, 8 AWG, Black, UL1028BK.
	M29/26080422	Wire, 8 AWG, Red, UL1028RD.
J2 Test Connector Harness Assembly PS5W2 M29/23011300		
J2	M29/40013002	Connector, 3 Pcs., Amp, 1-480701-0.
	M29/13037600	Terminal, Connector, Amp, 350218-1.
	M29/13024900	Terminal, Faston, Amp.
	M29/26160355	Wire, 16 AWG, Green, UL1015GN.
	M29/26160399	Wire, 16 AWG, White, UL1015WH.
	M29/26160300	Wire, 16 AWG, Black, UL1015BK.
F1 AC Fuse Wire Assembly W3, W4 M29/250074271		
	M29/13024900	Terminal, Faston, Amp.
	M29/26166600	Wire, 16 AWG, Black, UL1509BK.
Thermostat Wire Assembly W5, W6 M29/250074272		
	M29/13024900	Terminal, Faston, Amp.
	M29/26166600	Wire, 16 AWG, Black, UL1509BK.

*COMPONENTS, ADDED, DELETED OR CHANGED BY PRODUCTION CHANGES

PARTS LIST

SYMBOL	PART NO.	DESCRIPTION
Printed Circuit Card Assembly PS10A1 M29/91040000		
----- CAPACITORS -----		
C1 thru C3	M29/17033400	Electrolytic: 10,000 uF, 35 VDCW, +/- 10%.
C4	M29/17031901	Electrolytic: 2200 uF, 25 VDCW.
C5	M29/17018100	Ceramic: 0.1 uF, 50 VDCW, +/- 20%.
C6	M29/17018107	Ceramic: 0.001 uF, 100 VDCW.
C7 and C8	M29/17018100	Ceramic: 0.1 uF, 50 VDCW, +/- 20%.
C9	M29/17018214	Ceramic: 2200 pF, 100 VDCW, +/- 20%.
C10 and C11	M29/17016202	Electrolytic: 470 uF, 50 VDCW.
C12	M29/17018107	Ceramic: 0.001 uF, 100 VDCW.
C13	M29/17018214	Ceramic: 2200 pF, 100 VDCW, +/- 20%.
C14	M29/17018100	Ceramic: 0.1 uF, 50 VDCW, +/- 20%.
C15 thru C17	M29/17018214	Ceramic: 2200 pF, 100 VDCW, +/- 20%.
C18	M29/17016202	Electrolytic: 470 uF, 50 VDCW.
C20 and C21	M29/17018100	Ceramic: 0.1 uF, 50 VDCW, +/- 20%.
C22	M29/17012412	Ceramic: 1.0 uF, 50 VDCW, +/- 20%.
C23 thru C26	M29/17014503	Ceramic: 220 pF.
----- DIODES -----		
D1 and D2	M29/18207200	Rectifier: 30CPQ090.
D3 thru D5	M29/18018004	Rectifier: 1A, 150 V. UF4002.
D6	M29/19007500	Rectifier, Bridge: 1A, 400V. W04G.
D7 thru D19	M29/ 18018004	Rectifier: 1A, 150V. UF4002.
----- CONNECTORS -----		
J3 and J4	M29/40024401	Connector: 6 pos. AMP 640445-6.
J5 and J6	M29/40024402	Connector: 8 pos. AMP 640445-8.
J7 thru J17	M29/13048100	Connector: Faston Tab. AMP 62650-1.
----- RELAYS -----		
K1	M29/20003700	Relay: SPDT, 24V, 30A.
K2	M29/20004000	Relay: SPST, 12V, 40A.
K3	M29/20003600	Relay: SPST, 24V, 5A.
----- TRANSISTORS -----		

SYMBOL	PART NO.	DESCRIPTION
Q4	M29/18017600	Power: NPN. TIP-31C.
Q5	M29/18203500	Power: PNP. TIP-32C.
Q6 and Q7	M29/18023200	Gen. Purpose: NPN. MPS2222A.
Q8	M29/18023300	Gen. Purpose: PNP. MPS2907A.
Q9	M29/18023200	Gen. Purpose: NPN. MPS2222A.
----- RESISTORS -----		
R1 thru R3	M29/16013901	Wirewound: 0.15 ohms, 5w, 5%.
R4 thru R6	M29/16013900	Wirewound: 0.12 ohms, 5w, 1%.
R7	M29/16001573	Metal Film: 1k ohm, 1/2w, 5%.
R8	M29/16001464	Metal Film: 3.89K ohms, 1/4w, 1%.
R9	M29/16001443	Metal Film: 274 ohms, 1/4w, 1%.
R10	M29/16001525	Metal Film: 10K ohms, 1/4w, 1%.
R11	M29/16001448	Metal Film: 38.3K ohms, 1/4w, 1%.
R12	M29/16013500	Potentiometer: 1K ohms, 10%.
R13	M29/16001449	Metal Film: 8.25K ohms, 1/4w, 1%.
R14	M29/16001465	Metal Film: 274K ohms, 1/4w, 1%.
R15	M29/16001525	Metal Film: 10K ohms, 1/4w, 1%.
R16	M29/16001447	Metal Film: 4.32K ohms, 1/4w, 1%.
R17	M29/16001459	Metal Film: 237 ohms, 1/4w, 1%.
R18 and R19	M29/16001595	Metal Film: 5.11K ohms, 1/4w, 1%.
R20	M29/16001458	Metal Film: 36.5K ohms, 1/4w, 1%.
R21	M29/16001525	Metal Film: 10K ohms, 1/4w, 1%.
R22 and R23	M29/16001577	Metal Film: 7.5K ohms, 1/4w, 1%.
R24	M29/16001595	Metal Film: 5.11K ohms, 1/4w, 1%.
R25	M29/16001465	Metal Film: 274K ohms, 1/4w, 1%.
R26	M29/16001525	Metal Film: 10K ohms, 1/4w, 1%.
R27	M29/16001595	Metal Film: 5.11K ohms, 1/4w, 1%.
R28	M29/16001446	Metal Film: 45.3K ohms, 1/4w, 1%.
R29	M29/16007503	Potentiometer: 2K ohms, 1/2w, 10%.
R30	M29/16001477	Metal Film: 3.24K ohms, 1/4w, 1%.
R31	M29/16001525	Metal Film: 10K ohms, 1/4w, 1%.
R32 and R33	M29/16001591	Metal Film: 1.27K ohms, 1/4w, 1%.
R34	M29/16001599	Metal Film: 2K ohms, 1/4w, 1%.
R35	M29/16001591	Metal Film: 1.27K ohms, 1/4w, 1%.
R36	M29/16001445	Metal Film: 37.4K ohms, 1/4w, 1%.
R37	M29/16001595	Metal Film: 5.11K ohms, 1/4w, 1%.
R38	M29/16001493	Metal Film: 1.47K ohms, 1/4w, 1%.
R39	M29/16001469	Metal Film: 20k ohms, 1/4w, 1%.
R40	M29/16001478	Metal Film: 3.09K ohms, 1/4w, 1%.
R41	M29/16001437	Metal Film : 15.4K ohms, 1/4w, 1%.
R42	M29/16001470	Metal Film: 9.31K ohms, 1/4w, 1%.
R43	M29/16001464	Metal Film: 3.57K ohms, 1/4w, 1%.
R44	M29/16001471	Metal Film: 21.3K ohms, 1/4w, 1%.
R45	M29/16001525	Metal Film: 10K ohms, 1/4w, 1%.

SYMBOL	PART NO.	DESCRIPTION
R46 and R47	M29/16001582	Metal Film: 49.9K ohms, 1/4w, 1%.
R48 and R49	M29/16001525	Metal Film: 10K ohms, 1/4w, 1%.
R50	M29/16001526	Metal Film: 100 ohms, 1/4w, 1%.
R51 thru R53	M29/16001525	Metal Film: 10K ohms, 1/4w, 1%.
R54	M29/16001469	Metal Film: 20K ohms, 1/4w, 1%.
----- VARISTORS -----		
RV1	M29/18008011	Varistor. GE V275LA2UA.
----- TRANSFORMER -----		
T1 and T2	M29/FS56-020	Transformer, Power.
----- INTEGRATED CIRCUITS -----		
U1	M29/19005701	Voltage Regulator: +15V. LM78L15.
U2	M29/19010500	Reference Voltage. AD680JT.
U3	M29/19009900	Regulator. SG3532J.
U4	M29/19019676	Regulator. LM317T.
U5	M29/19009100	Voltage Regulator. TL431C.
U6 and U7	M29/19010000	Dual Comparator. LM393AN.
U8	M29/19006000	Dual Operational Amp. LM358.
U9	M29/19008100	Regulator. MC14013.
----- ZENER DIODES -----		
VR1	M29/18001443	Zener: 13V, 1/2w, +/-5%.
VR2	M29/18001425	Zener: 6.8V, 1/2w, +/-10%.
----- MISCELLANEOUS -----		
	M29/11023500	Heatsink, Thermalloy.
	M29/31016703	Heatsink Thermal Pad.
	M29/91031600	Heatsink Assembly.
	M29/91035700	Heatsink Assembly.
	M29/22041503	Nut: #10-32, Keeper, 1/8" thick.
	M29/22045500	Stud, Pem: #10-32.
Power Transistor Heat Sink Assembly PS10A2 M29/91037100		
Q1 thru Q3	M29/18030800	Transistor, Power: NPN. 2N5885.
S1	M29/09017000	Thermostat: SPST, normally closed. 1NT01L-1928.
	M29/11025900	Heatsink.
	M29/11026000	Heatsink.
	M29/13051800	Socket, TO-3.
	M29/31023200	Insulator.
	M29/07062500	Cover, TO-3.
	M29/22009007	Screw, #6-32 x 0.625.

SYMBOL	PART NO.	DESCRIPTION
	M29/22021508	Screw, #4-40 x 0.25.
	M29/22047900	Screw, #6-32 x 5/8.
AC Fuse Wire Assembly M29/250074270		
	M29/09017300	Fuseholder. HTB-36M.
	M29/09016000	Fuse: 5A, 250V. GDA-5.

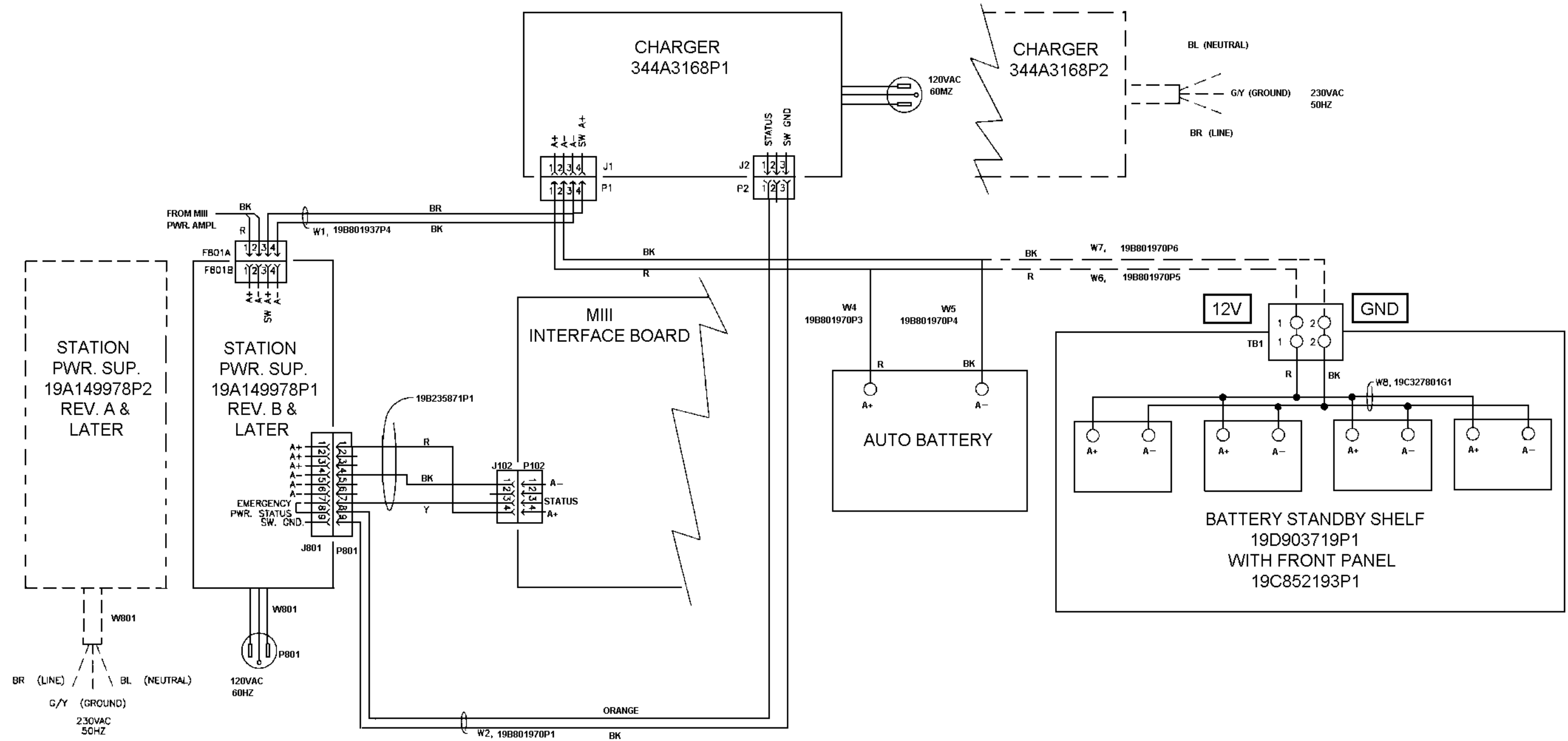

**MASTR III STATION
WITH EMERGENCY POWER**

(19D903635, Sh. 3, Rev. 2)

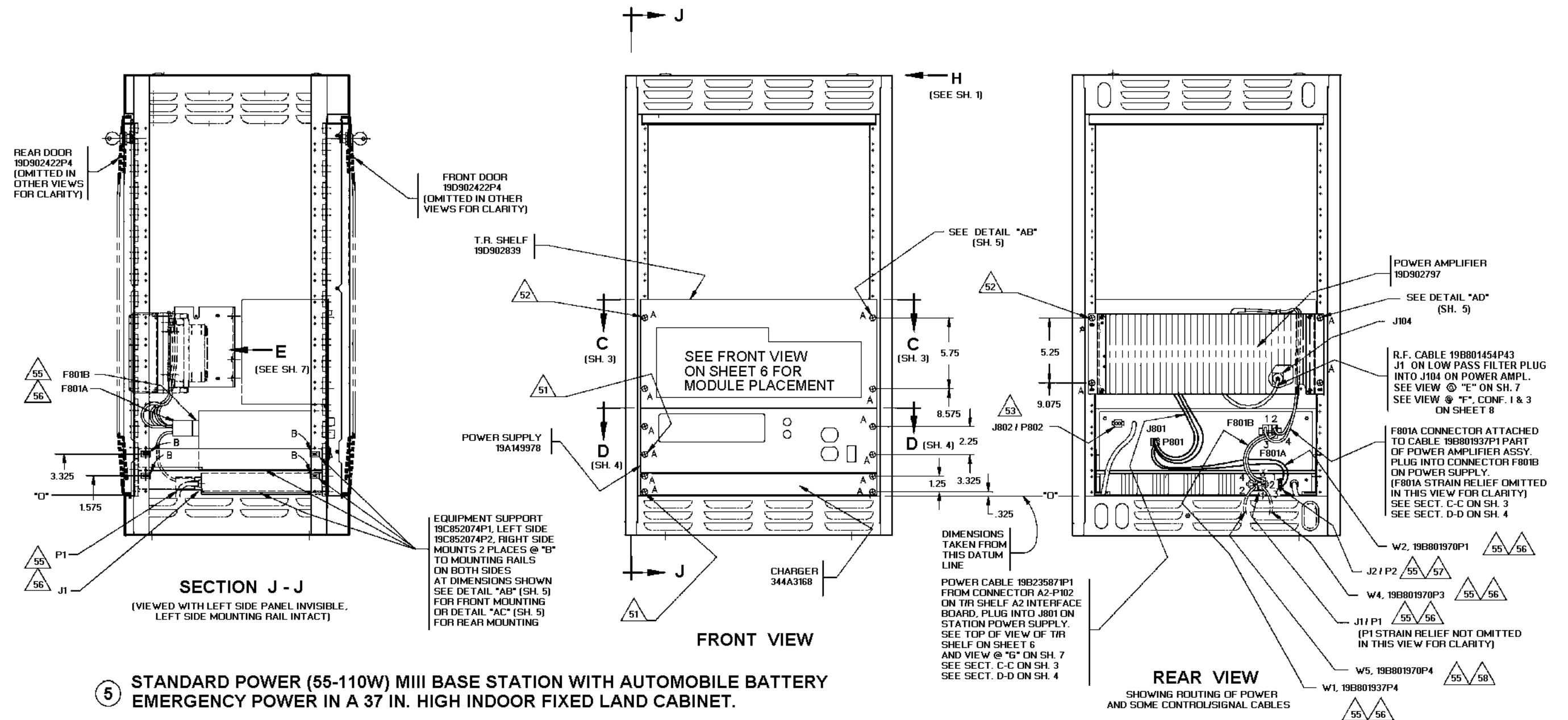

NOTES:

- 51. ITEMS REFERENCING THIS CALLOUT ARE CALLED FOR ON HARDWARE KIT PL344A3450G1.
- 52. ITEMS REFERENCING THIS CALLOUT ARE CALLED FOR ON HARDWARE KIT PL344A3450G2.
- 53. REMOVE P802 FROM J802 ON POWER SUPPLY 19A149978.
- 54. INSTALL CABLES AS SHOWN AND INTERCONNECT IN ACCORDANCE WITH INTERCONNECT DIAGRAM 19D903635. SEE ALSO NOTES 55, 56, & 57.
- 55. INTERCONNECTION OF CABLES IN NOTES 56 & 57 TO BE CONSISTENT WITH INTERCONNECT DRAWING 19D903635.

- 56. REMOVE F801A OF PA LEAD ASSEMBLY 19B801937P1 FROM F801B OF POWER SUPPLY. REMOVE STRAIN RELIEFS FROM F801A AND FROM P1 OF W1. INSERT THE BROWN WIRE OF W1 INTO THE NUMBER 3 CAVITY OF F801A. INSERT THE BLACK WIRE OF W1 INTO THE NUMBER 4 CAVITY OF F801A. INSERT THE CONTACT END OF W4 INTO THE NUMBER 1 CAVITY OF P1 OF W1. INSERT THE CONTACT END OF W5 INTO THE NUMBER 2 CAVITY OF P1 OF W1. REINSTALL STRAIN RELIEFS FOR P1 OF W1 AND F801A. PLUG P1 OF W1 INTO J1 OF THE CHARGER. PLUG F801A INTO F801B OF THE POWER SUPPLY. CABLES W4 AND W5 ARE TO BE LEFT ROLLED UP AND LYING ON THE FLOOR OF THE CABINET.
- 57. PLUG P2 OF W2 INTO J2 ON THE CHARGER. INSERT THE ORANGE WIRE OF W2 INTO THE NUMBER 8 CAVITY OF P801 OF CABLE ASSEMBLY 19B23587P1. INSERT THE BLACK WIRE OF W2 INTO THE NUMBER 9 CAVITY OF P801 OF CABLE ASSEMBLY 19B23587P1.

- 58. FOR 13 INCH DEEP CABINET MOUNTING, USE REAR SUPPORTS 19B226160 SUPPLIED WITH HARDWARE KIT 344A3696G1. RETURN ANY UNUSED SUPPORTS TO STOCK.

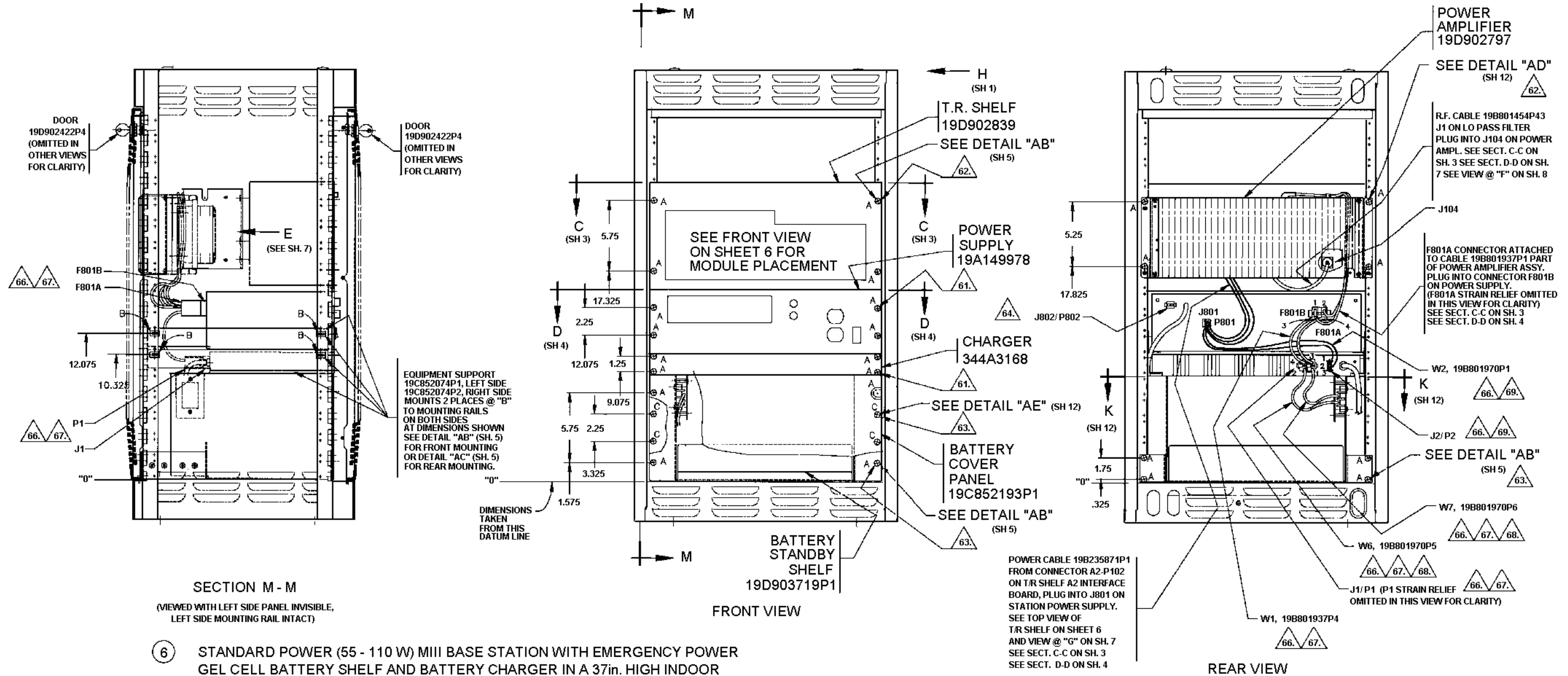

6 STANDARD POWER (55 - 110 W) MIII BASE STATION WITH EMERGENCY POWER GEL CELL BATTERY SHELF AND BATTERY CHARGER IN A 37in. HIGH INDOOR FIXED LAND CABINET.

MASTR III STATION

(19D902845, Sh. 11, Rev. 1)

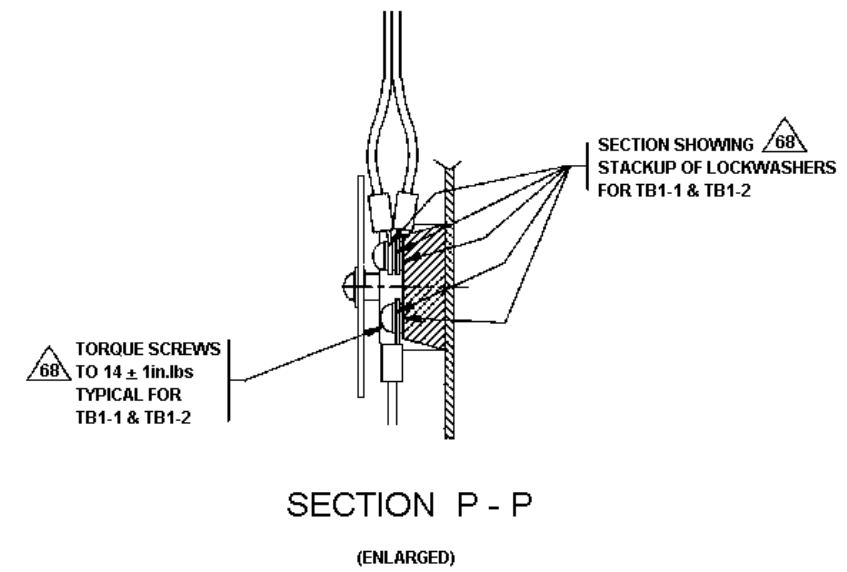
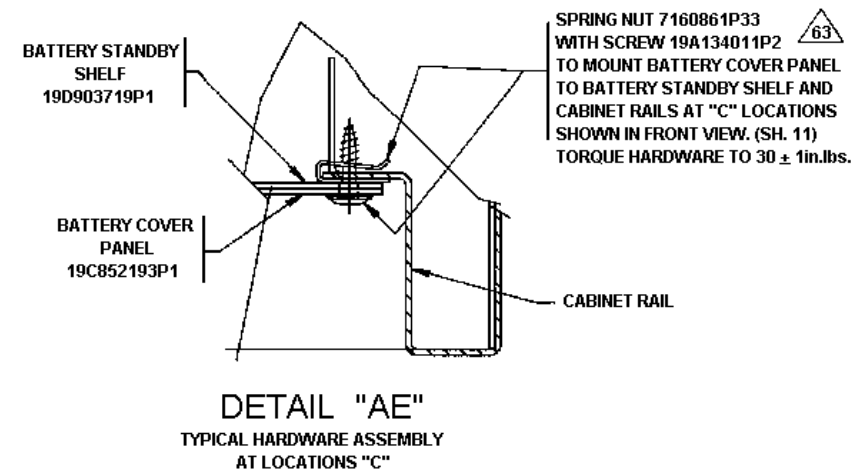
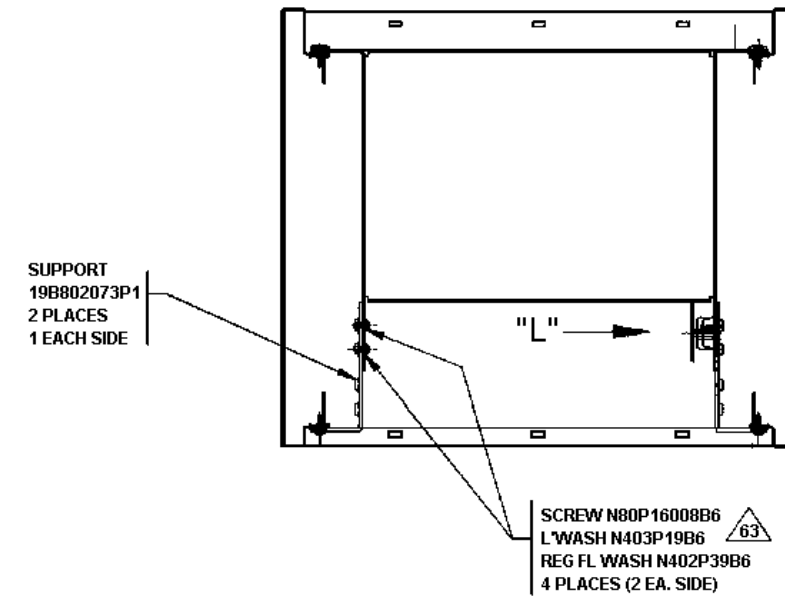
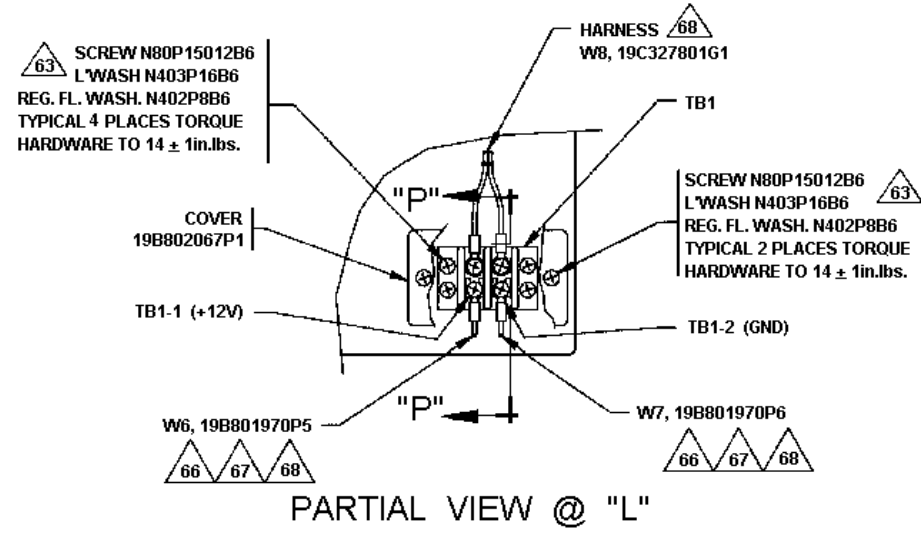

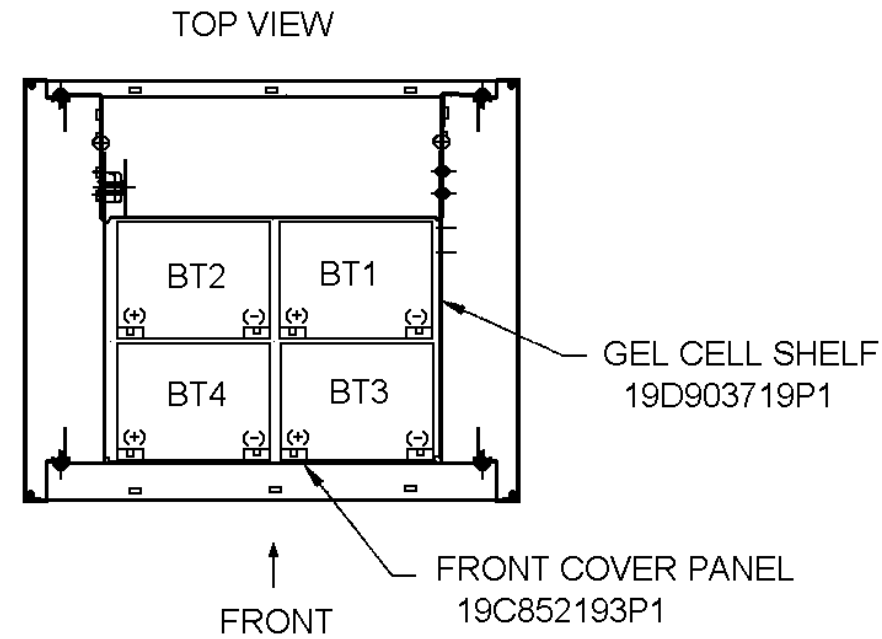

FIGURE 1

1 FIELD INSTALLATION OF GEL CELL BATTERIES IN THE EMERGENCY POWER GEL CELL BATTERY SHELF FOR A MI37 in. HIGH INDOOR FIXED LAND CABINET.

1. REMOVE GEL CELL SHELF FRONT COVER PANEL 19C852193P1.
2. INSTALL BT1, BATTERY 19B209590P1, INTO GEL CELL SHELF 19D903719P1 AS SHOWN IN FIGURE 1. ATTACH A RED WIRE FROM HARNESS W8 (19C327801G1) TO THE "(+)" TERMINAL. ATTACH A BLACK WIRE FROM HARNESS W8 (19C327801G1) TO THE "(-)" TERMINAL.
3. IN ORDER, INSTALL BT2, BT3, AND BT4 PER STEP 2 INSTRUCTIONS. IT IS ADVISABLE TO POSITION THE GEL CELLS SO THAT THEY ARE NOT TOUCHING EACH OTHER OR THE GEL CELL SHELF WALLS AND ARE APPROXIMATELY 0.15" AWAY FROM EACH OTHER.
4. REINSTALL GEL CELL SHELF FRONT COVER PANEL 19C852193P1.

BATTERY SHELF

(344A4051, Sh. 1, Rev. 1)

This page intentionally left blank