

future
The Future of Mobile Radio

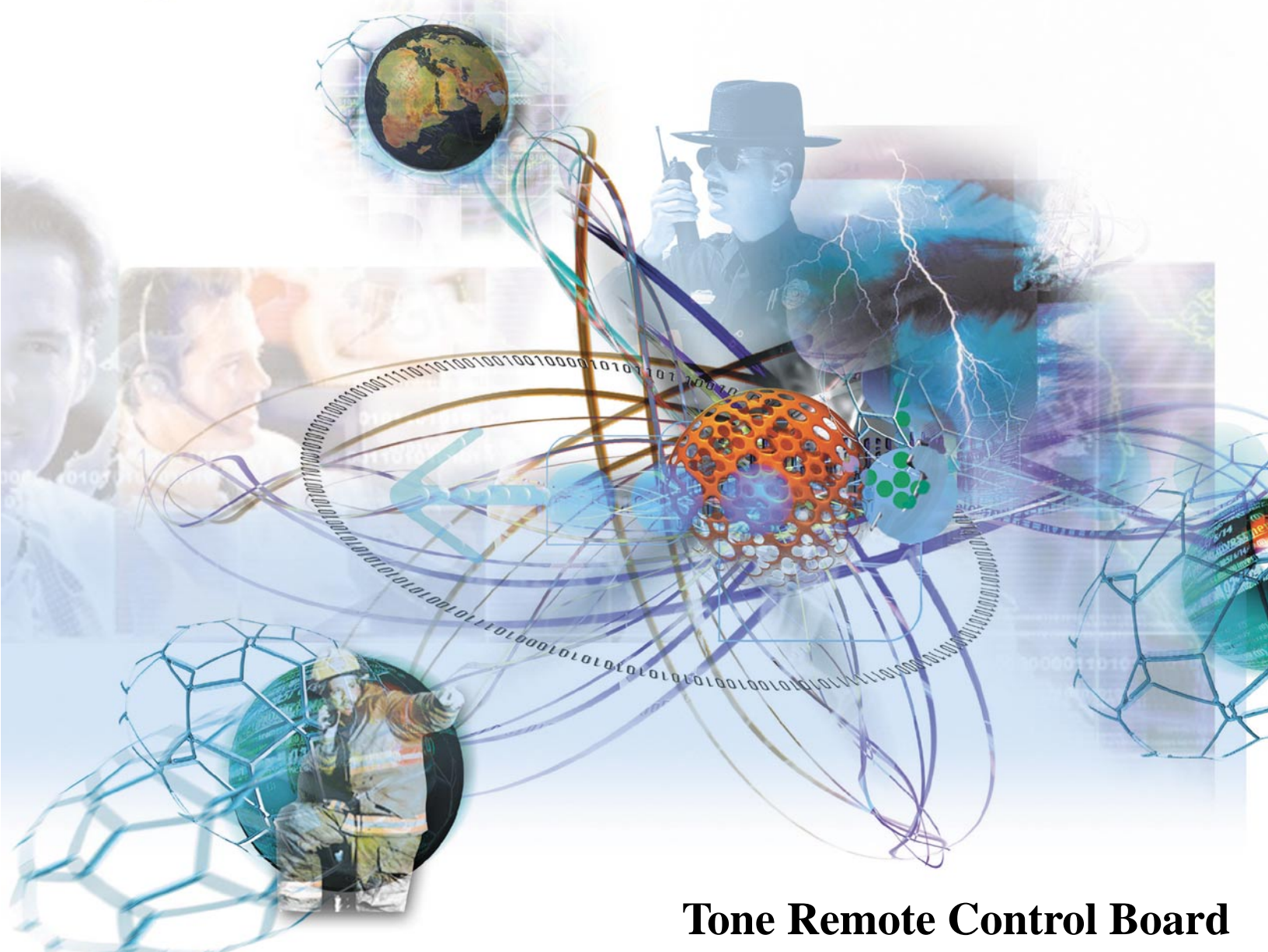

Tone Remote Control Board

19A704686P4

(1-Frequency Transmit and Receive with Channel Guard)

19A704686P6

(4-Frequency Transmit and Receive with Channel Guard)

TABLE OF CONTENTS

	<u>Page</u>
DESCRIPTION	1
Control Functions	1
Tone Control Sequence	1
CIRCUIT ANALYSIS	1
Transmit Audio	1
Receive Audio	2
Control Tones	2
Power-On Reset	2
ADJUSTMENT PROCEDURE	3
TROUBLESHOOTING PROCEDURE	3
OUTLINE DIAGRAM & SCHEMATIC DIAGRAMS	
TONE REMOTE CONTROL BOARD 19A704686P4 & P6	4
TONE REMOTE CONTROL BOARD 19A704686P4	5
PARTS LIST	
TONE REMOTE CONTROL BOARD 19A704686P4	6
TONE REMOTE CONTROL BOARD 19A704686P6	8

SPECIFICATIONS*

LINE TERMINATING IMPEDANCE	600 ohms
LINE LOOP IMPEDANCE (MAXIMUM)	11,000 ohms (8000 line and 3000 matching)
INPUT VOLTAGE	+10 Volts DC ±0.5 Volts
CURRENT (standby & transmit)	50 milliamperes maximum
LINE LEVEL (Line to Transmitter)	-20 to +11 dBm
OUTPUT LEVELS	
Transmit	10-200 millivolts (adjustable)
Receive	-20 to +7 dBm
DISTORTION (300-1000-3000 Hz)	
Transmit	Less than 3%
Receive	Less than 5%
FREQUENCY RESPONSE	+1, -3dB from 300 to 3000 Hz (except 2175 Hz notch)
2175 Hz NOTCH FILTER	-40 dB
TEMPERATURE RANGE	-30°C to +75°C (-22°F to +153°F)

* These specifications are intended primarily for the use of the serviceman. Refer to the appropriate Specification Sheet for the complete specifications.

DESCRIPTION

Tone remote control boards 19A704686P4 and 19A704686P6 are used in remote and local/remote station combinations to provide one-through four-frequency transmit and receive functions with Channel Guard disable (channel monitor). The tone remote boards provide the interface between a remote control console and the base station.

Tone remote board 19A704686P4 is used in one-frequency transmit and receive desk top (local remote) stations with Channel Guard (CG) disable. Tone remote board 19A704686P6 is used in four-frequency transmit and receive wall mount (remote) stations with CG disable. The P6 board is also used in CIU applications (refer to LBI-31761).

Connections from the remote control console are made at J1 on the tone remote control board. Interconnections to the station are made at J2, and to J3 on the four-frequency tone board. Supply voltage for the tone remote board is provided by the station regulated +10 volts.

CONTROL FUNCTIONS

Tone control board 19A704686P4 provides three control functions. Tone control board 19A704686P6 provides a maximum of 7 control functions. The functions are accomplished by applying up to three tones in sequence from the remote control console for detection at the tone remote control board. The control frequencies selected at the remote control console for the different functions are shown in Table 1.

Table 1 - Tone Control Frequency and Function

FUNCTION	TONE FREQUENCY
RX Channel Guard Disable (Reset by PTT)	2050 Hertz
TX-RX Freq. No. 1	1950 Hertz
TX-RX Freq. No. 2 *	1850 Hertz
TX-RX Freq. No. 3 *	1350 Hertz
TX-RX Freq. No. 4 *	1250 Hertz
TX Hold (Secur-it Tone)	2175 Hertz

* 19A704686P6 Only

TONE CONTROL SEQUENCE

All of the station functions selected by the remote control console are accomplished by a sequence of two or three tones at the proper level for detection at the tone remote control board.

When a non-transmit function is selected at the remote control console, the Secur-it tone frequency of 2175 Hz is transmitted for a period of 125 milliseconds at a level equal to normal voice peaks. In the case of a 0 VU line level, the Secur-it tone is transmitted at a level of +10 dBm. At the end of this 125 milliseconds, the tone is changed to that of the function frequency selected. This function tone is transmitted for a period of 40 milliseconds at a level of 10 dB below the Secur-it tone burst.

The tone level and timing sequence is shown in Figure 1.

When a transmit function is selected at the remote control console, the Secur-it tone is transmitted as in the sequence described above, followed by a 40 ms burst of the F1 or F2 transmit function hold tone. This is followed by the 2175 Hz tone transmitted at a level 30 dB below its initial Secur-it burst level. The low level 2175 Hz tone remains on in the presence of voice as long as the PTT switch is operated at the remote control console.

CIRCUIT ANALYSIS

The tone remote control board provides the transmit and receive select functions, transmitter keying and Channel Guard disable functions. The tone remote board also provides the audio path between the remote control console and the station for transmit and receive audio.

The operation of the two remote control boards are nearly identical except for transmit/receive frequency selection.

TRANSMIT AUDIO

Audio and control tone from the remote console are applied to the tone remote control board at J1-3 and J1-4. The audio and tones are coupled through transformer T1 to line pre-amplifier input of op-amp U12-2. The pre-amp output level is set by R59. VR1 and VR2 provide telephone line surge protection.

The pre-amp output at U12-1 is coupled through bilateral switch section U13, pins 4 and 3 to a 2175 Hz notch filter consisting of U18. The notch filter removes the 2175 Hz push-to-talk (PTT) hold tone generated by the remote control console when in the transmit mode.

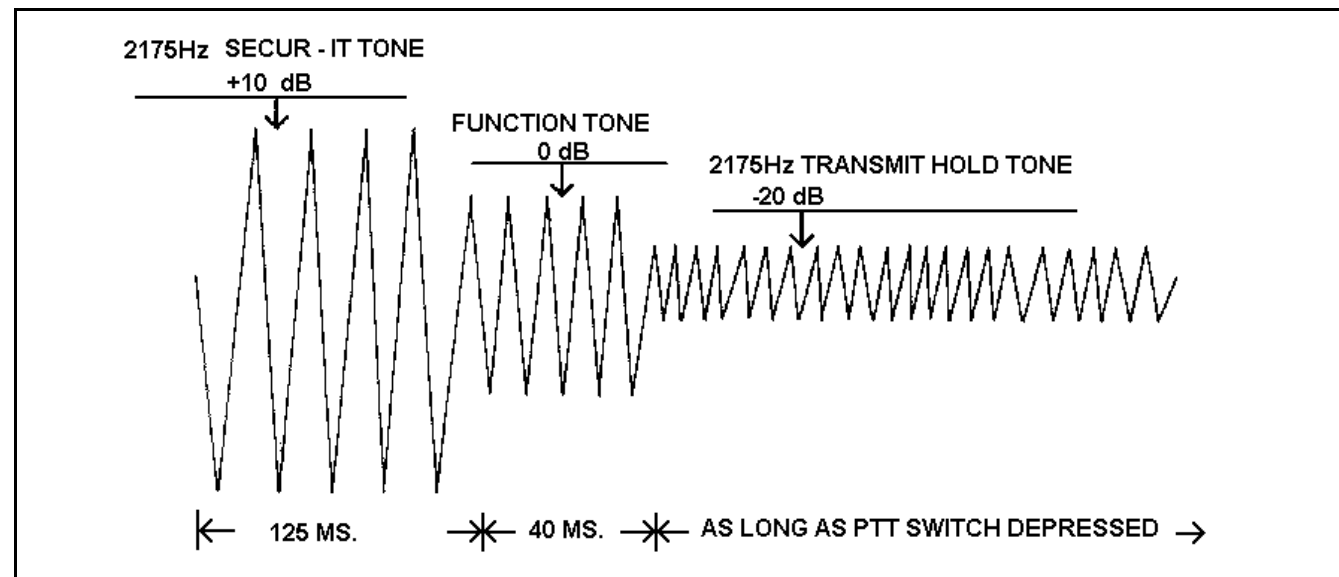

Figure 1 - Control and Function Tones

Notch filter U18 is switched between the transmit and receive mode by the four bilateral switches in U13. The bilateral switches are controlled by three outputs:

- Receiver unsquelched sensor (RUS) line from the station which goes high (10 VDC) when the station receiver unsquelches, and low when the receiver is squelched.
- Transistor Q10: turns on when a PTT hold tone is received, and turns off when the hold tone is removed.
- Pin 9 of U20: goes low after 100 milliseconds of 2175 Hz Secur-it tone (at 10 dBm level) is received.

The notch filter output is coupled through U13, pins 10 and 11 to mic driver stage input, U12-6. This section of op-amp U12 has a voltage gain of X2, and the output level is set by R60. The amplified audio output at U12-7 is then applied to the station transmitter through J2-1 (MIC AUDIO).

RECEIVE AUDIO

Audio from the station receiver is applied to the tone remote control board through J2-9 (RX AUDIO). The receive audio is coupled through a passive low-pass filter which provides 6dB/octave de-emphasis. The filter consists of C30 and R83. The filter output is applied to the input of op-amp U8-2. U8 has a voltage gain of X45.

When the RUS line (J2-12) is high, the receive audio is coupled through U13 pins 1 and 2, and applied to notch filter U18. The filter output is coupled through bilateral switches

U13 pins 8 and 9, and U7 pins 10 and 11. U7 is also controlled by the RUS line, Q10 and U20-9.

The output at U7-11 is coupled through RX audio level control R35 to the remote line drivers consisting of both sections of op-amps U6. The output of U6 drives line transformer T1, and applied to the control pair. **SERVICE NOTE:** U6 can drive the control pair to a level of +7 dBm when the line is terminated in a 600-ohm load. However, an output level of more than +11 dBm can be obtained by removing jumper JP1 at U6-8, and connecting U6-8 to 13 volts DC.

CONTROL TONES

The control tones (and voice audio) are coupled through J1-3 and J1-4, audio transformer T1 and applied to line pre-amplifier U12-2. The description of the voice audio circuitry was described in the preceding paragraphs. The following paragraphs contain a description of the Secur-tone, control tones and PTT "hold" tone.

Secur-it Tone

The pre-amp output of U12-1 is coupled through capacitor C49 to a high "Q", 2175 Hz bandpass filter (U14). The filter output at U14-8 is rectified by diodes D1 and D2, and the resultant positive voltage applied to comparator U9-3. If the input voltage to U9-3 is high enough, the comparator output at U9-1 will go high. Line pre-amp level potentiometer R59 is adjusted so that the +10 dBm Secur-it tone will cause U9-1 to go high.

The comparator output is applied on AND gate (U19-13), and to one half of a dual monostable multivibrator (U20-4). The output at U9-1 will remain high for the 125 millisecond duration of the Secur-it tone.

The portion of monostable vibrator U20 that is controlled by the input at pin 4 is used as a validation timer. The time is determined by the RC time constant of R96 and CSS. The time constant is 100 milliseconds. Therefore, the Secur-it tone must be present for at least 100 milliseconds before the second half of U20 is activated. This section of U20 also has a time constant of 100 milliseconds (R97 and C57).

When the second section of U20 is activated, U20-10 goes high, turning on bilateral switch U7 pins 4 and 3. This couples the function tones to the applicable tone decoders. Also during this 100 millisecond time frame, U20-9 goes low, turning off bilateral switches U13 and U7 in the receive audio path. This prevents any interference with the function tone decoding.

Function Tones

The function tones are decoded by phase lock loop decoders U1 through U5. The detection frequency is determined by the capacitor across pins 13 and 14, and the resistance from pin 12 to ground. The decoder tones and functions are shown in Table 2.

Table 2 - Decoder Tones and Functions

DECODER	DECODE FREQUENCY	FUNCTION
U1	2050 Hz	CG Disable (RX Mon.)
U2	1950 Hz	F1 select
U3	1850 Hz	F2 select
U4	1350 Hz	F3 select
U5	1250 Hz	F4 select

Tone adjust potentiometers R3, R9, R15, R21 and R27 are set at the factory and should need no further adjustment. However, if one of the decoders or associated circuitry is replaced, set the decoders as directed in the Adjustment Procedure (see Table of Contents).

When one of the function tones is decoded, pin 6 of the selected PLL IC goes high. This high sets the output of the associated U17 latch (U15 for CG DISable) high. On the 19A704686P6 board, the other three U17 latches are reset at

the same instant by OR gates U11 and U16. This circuitry assures only one frequency is selected. Transistors Q1-Q4 invert and buffer the frequency select lines and apply them to the station via J3.

Function tones also key the transmitter when pin 6 of a tone decoder is high. Diodes D8, D9, D10 and D11 "OR" the decoders' outputs and D14 pulls U9-5 high. This signal holds PTT low via the comparator until the hold tone detector circuit takes over.

In addition, U15-10 is latched high by a function tone. This high is applied to AND gate U19-2 to enable passage of the hold tone through U7 pins 8-9.

Transmit Hold Tone

A 0 dBm function tone keys the transmitter and the -20 dBm, 2175 Hz hold tone keeps the transmitter keyed.

After a function tone is decoded, pin 12 of RS latch U15 is set, and U15-10 goes high. This high is applied to AND gate U19-2. As U19-1 is already high due to the validation of the Secur-it tone, U19-3 goes high. This turns on U7, allowing the -20 dBm hold tone output at U14-8 to pass to the hold tone detector circuit. The 2175 Hz bandpass filter output at U14-8 is applied to op-amp U8-6. U8 has a voltage gain of X100, and clips the 2175 Hz at output pin U8-7. This output is rectified by diodes D3 and D4, and applied to comparator U9-5 to hold PTT low. In addition to keying the transmitter the high output of U9-7 also resets RS latch U15-3 which controls the Channel Guard disable function.

U9-7 is high with a valid function or hold tone. When the hold tone ends U9-7 returns low (and PTT returns high). This low triggers one of the monostable multivibrators in U10 at pin 11. This monostable is set for a duration of 1 ms by C37 and R54. The 1 ms positive pulse appears on U10-10 to reset the two U15 latches. This action disables the 2175 Hz tone path through U7 pins 8-9 to the hold tone detector circuit.

POWER-ON RESET

One-half of dual monostable multivibrator U10 produces a power-on reset pulse for the board. Approximately one second after power-on, U10-6 goes high for a duration of 100 ms. C35 holds the trigger input low for approximately one second. C36 and R53 set the pulse duration.

This reset pulse is fed through D13 to comparator U9. U9-7 goes high and triggers the second monostable by U10-11. The 1 ms pulse at U10-10 resets the two U15 latches and the CG DIS latch U15 is reset by U9-7. On the 19A704686P6 board, this reset pulse resets F2, F3 and F4 latches (U17) via D7, D5 and D6 respectively.

ADJUSTMENT PROCEDURE

Tone remote control board 19A704686P4 has eight controls; three audio level controls and five tone level adjustments. Tone remote control board 19A704686P6 has 11 controls, three audio controls and eight tone level adjustments. The three audio controls should be adjusted when the system is installed. The tone level controls are set at the factory and may not require field adjustment unless the tone filters or decoders or associated circuitry are replaced.

Make sure that all connections to the base station and remote control console have been completed, and that the remote console and base station have been properly aligned before adjusting the tone remote control board.

EQUIPMENT REQUIRED

1. AC Voltmeter with dBm scale
2. Deviation Monitor
3. Frequency Counter
4. Audio Generator

RECEIVE AUDIO (R35)

1. Apply a 1000 Hz tone with ± 3 kHz deviation to the station receiver that is strong enough to fully quiet the receiver.
2. Adjust RX AUDIO LEVEL control R35 for 0 dBm across terminals J1-3 and J1-4.

2175 Hz SET (R82)

Key the remote control console which should generate the 2175 Hz tone. Adjust R82 for maximum level at U14-8.

LINE PRE-AMP (R59)

Key the remote control console having the largest loss to key the base station transmitter. If the station transmitter does not key, adjust LINE PRE-AMP control R59 and re-key the remote control console to key the station transmitter.

TX MIC AUDIO (R60)

1. Apply a 1000 H tone into the microphone jack of the remote control console having the largest line loss. Adjust the remote control console line output

control for 2.7 Volts RMS as measured across the audio pair at the remote console.

2. Key the Base Station Transmitter from the remote control console and adjust TX MIC AUDIO control R60 for ± 4.5 kHz deviation.

FUNCTION DECODERS

NOTE

The following adjustments are not normally required for the initial installation.

The adjustment of each of the function tone decoders is identical except for the frequency to be decoded. Adjust U1-R3, U2-R9, U3-R15, -U4-R21 or U5-R27 as follows:

1. Remove the 0.1 microfarad capacitor from pin 10 to ground.
2. Jumper pins 2 and 10 together. Pin 3 should now oscillate near the detection frequency.
3. Connect a frequency counter to pin 3 and adjust the proper decoder potentiometer for the correct frequency to be decoded.
4. After making the adjustments, remove the jumper from pin 2 to pin 10 and replace the 0.1 microfarad capacitor from pin 10 to ground.

NOTCH FILTER (R70 & R81)

1. Feed a 2175 Hz signal to J1-3 and J1-4. The input level should not exceed 1.2 Volts RMS.
2. Adjust R81 for a minimum meter reading on U18-7.
3. Re-adjust R70 for a minimum tone on U18-1.
4. While metering the output at U18-7, adjust both R70 and R81 slightly for more attenuation of the 2175 Hz tone.

BANDPASS FILTER

1. Feed a 2175 Hz signal to J1-3 and J1-4, with the signal level no greater than 1.2 Volts RMS.
2. Adjust R82 for a maximum level of 2175 Hz tone at U14-8.

TROUBLESHOOTING PROCEDURE

remote controller and tone remote board have been properly adjusted.

Before Troubleshooting the tone remote control board, check all connections to the remote control console, tone remote board and base stations. Make sure that the station, re-

SYMBOL	PROCEDURE
No audio from base station to remote(s):	<ol style="list-style-type: none"> 1. Check setting of R35. May be misadjusted (set too low). 2. Check U8. Pins 1, 2, and 3 should be at 5 VDC. Audio should appear on pin 1. 3. Check Q6. Transistor may always be off. 4. Check U7. Pin 12 should be high for audio to pass from pin 10 to pin 11. 5. Check U6. Pins 1,2,3,5,6 and 7 should be at 5 VDC. Audio should be present on both pins 1 and 7.
2175 Hz tone being transmitted:	<ol style="list-style-type: none"> 1. Over deviating mic audio. Adjust R60 so that voice audio does not exceed full system deviation. 2. Check U18. Pin 7 of U18 should have over 40 dB of attenuation at 2175 Hz. 3. R70 and/or R81 not adjusted properly.
Secur-it tone not detected:	<ol style="list-style-type: none"> 1. Line pre-amp not adjusted properly (R59). 2. U12 faulty. Pins 1,2, and 3 should have 5 VDC present. 3. R82 not adjusted properly or U14 faulty. 4. Check U9. When the pin 3 voltage exceeds the DC voltage on pin 2, the output at pin 1 goes high. (+10 Volts). 5. Check U19 or U20. U20-4 should be high for 100 mS before U20-10 goes high.
No function tone decoded:	<ol style="list-style-type: none"> 1. Check U20. Pin 10 should go high for 100 mS, which allows an audio path to the function tone decoders. 2. Check U7. When pin 5 is high, audio should pass from pin 4 to pin 3.
Transmit hold tone not detected:	<ol style="list-style-type: none"> 1. Check U19. After Secur-it tone and transmit function tone have been decoded, pin 3 of U19 should be high. 2. Check U7. When pin 6 is high, 2175 Hz bandpass output should pass from pin 8 to pin 9. 3. Check U8. The 2175 Hz signal should be clipped at pin 7. 4. Check U9. When the DC voltage on pin 5 is greater than pin 6, pin 7 should go high.
No transmit audio:	<ol style="list-style-type: none"> 1. Check U13. When pin 12 is high, audio should pass from pin 10 to pin 11. 2. Check Q6. When Q6 is off pins 5 and 12 of U13 should be high; pins 6 and 13 low. 3. Check U12. Pins 5,6, and 7 should have 5 VDC present. 4. Check setting of MIC AUDIO adjust R60. May be misadjusted (set too low).

COMPONENT SIDE

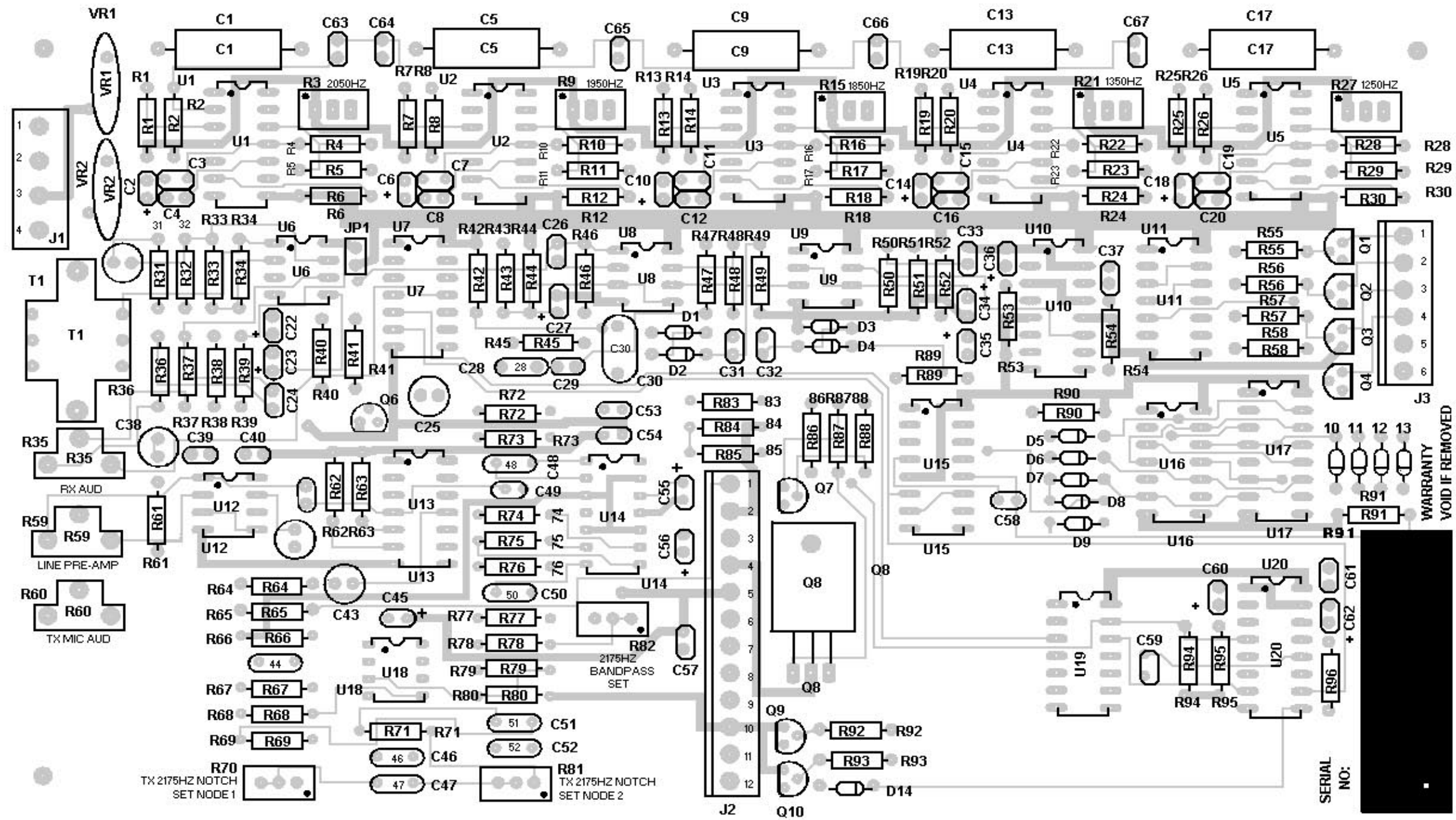

(4135-A-04, Rev. E)
(4135-A-01, Rev. E)

TONE REMOTE CONTROL BOARD
19A704686P4 & P6

LAST USED:	NOT INSTALLED:
C67 Q10	C9 THRU C20, C59, C65, C66, C67
D14 R96	D5, 6, 7, 11, 12, 13
J3 U20	J3
JP1 WR2	Q1, 2, 3, 4, 5
	R13 THRU R30, R55, 56, 57, 58
	U3, 4, 5, 11, 16, 17

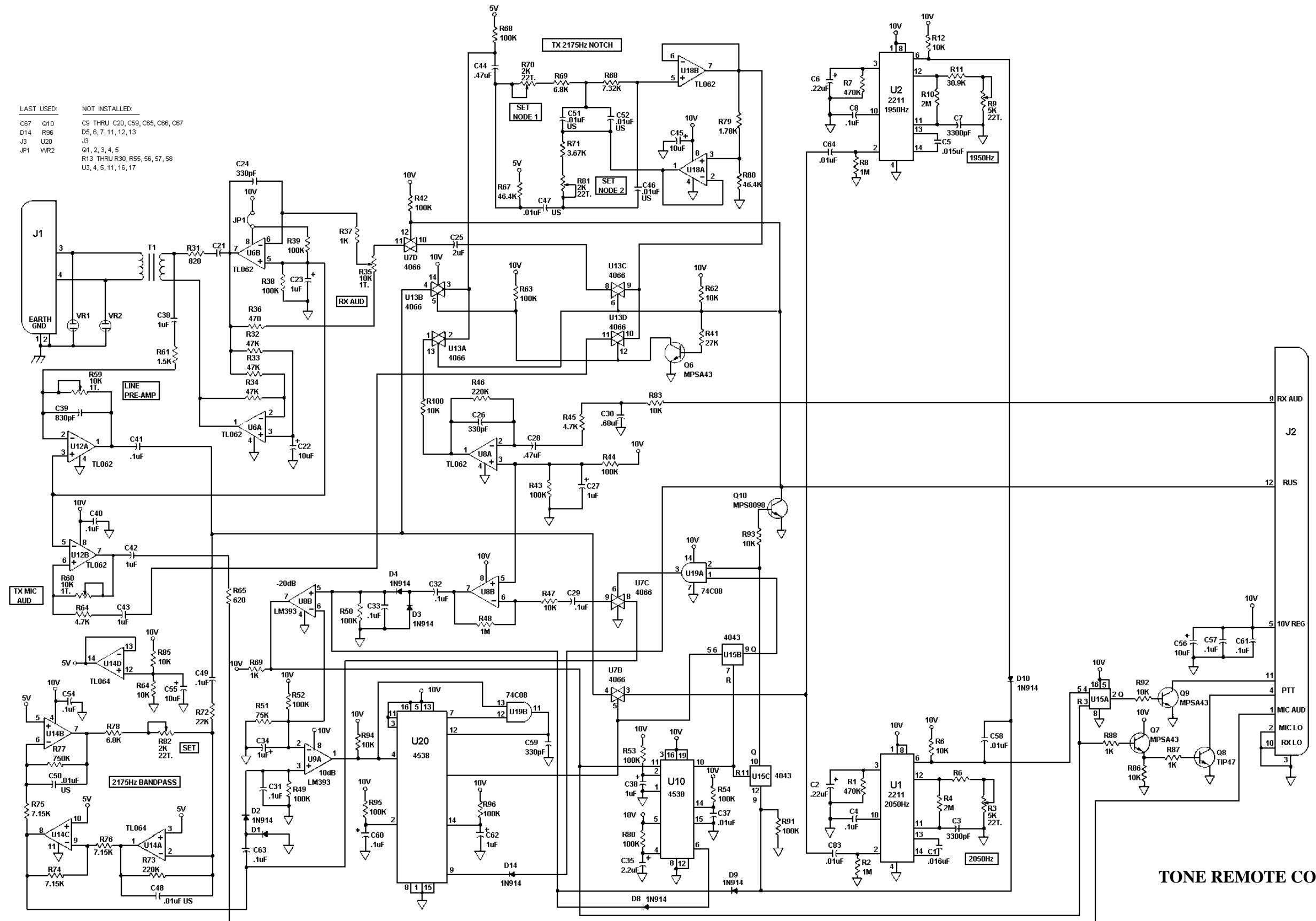

TONE REMOTE CONTROL BOARD
19A70468P4

(4135-S-00, Rev. G)

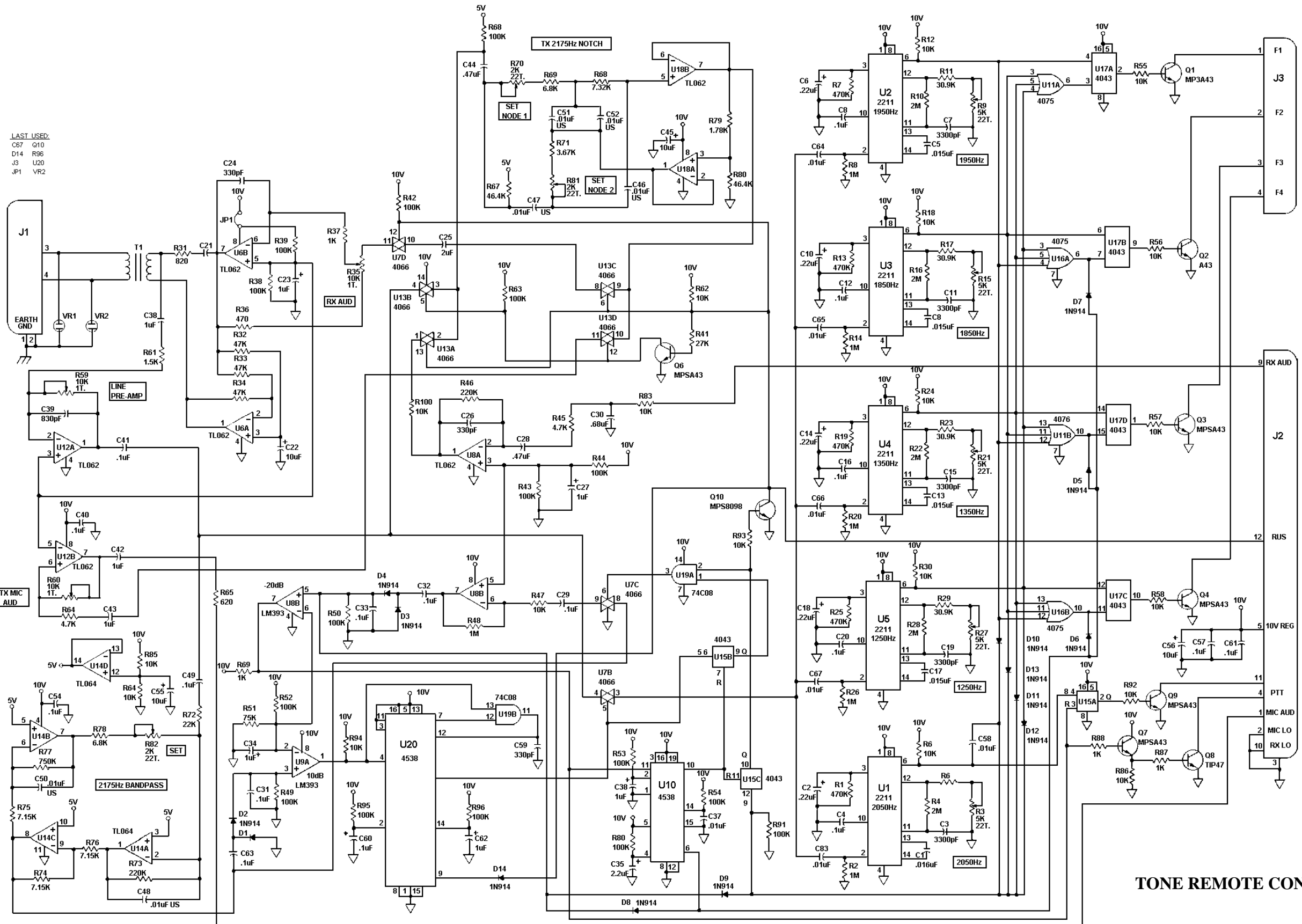

LAST USED:
C67 Q10
D14 R96
J3 U20
JP1 VR2

TONE REMOTE CONTROL BOARD
19A704686P6

(4135-S-00, Rev. G)

This page intentionally left blank