



Control Unit for M7100, JAGUAR™ 725M, and Orion™

Local Scan Model (Orion) KRY 101 1632/11

Remote Scan Model KRY 101 1632/12

Local System Model (Orion) KRY 101 1632/13

Remote System Model KRY 101 1632/14

Local Scan Model (M7100 & JAGUAR) KRY 101 1632/17

Local System Model (M7100 & JAGUAR) KRY 101 1632/19

Remote Interface Adaptor NQZ-4882C

MANUAL REVISION HISTORY

REV	DATE	REASON FOR CHANGE
R1A	1997	Initial Release
B	May/05	Added Disassembly & Assembly procedure, updated Parts List & drawings for Panel Control board, updated schematics for Switch Circuit board, added /17 & /19 part numbers.
C	Jan/09	Added information on Orion Control Unit Test.

Technical Publications would particularly appreciate feedback on any errors found in this document and suggestions on how the document could be improved. Submit your comments and suggestions to:

Tyco Electronics Wireless Systems
Technical Publications
221 Jefferson Ridge Parkway
Lynchburg, VA 24501

or fax your comments to: (434) 455-6851

or e-mail us at: techpubs@tycoelectronics.com

CREDITS

Orion and JAGUAR are trademarks of M/A-COM, Inc.

TORX is a registered trademark of Camcar Innovative Solutions.

All other brand and product names are trademarks, registered trademarks, or service marks of their respective holders.

NOTICE!

This manual covers M/A-COM, Inc., products manufactured and sold by M/A-COM, Inc.

NOTICE!

Repairs to this equipment should be made only by an authorized service technician or facility designated by the supplier. Any repairs, alterations or substitutions of recommended parts made by the user to this equipment not approved by the manufacturer could void the user's authority to operate the equipment in addition to the manufacturer's warranty.

This manual is published by **M/A-COM, Inc.**, without any warranty. Improvements and changes to this manual necessitated by typographical errors, inaccuracies of current information, or improvements to programs and/or equipment, may be made by **M/A-COM, Inc.**, at any time and without notice. Such changes will be incorporated into new editions of this manual. No part of this manual may be reproduced or transmitted in any form or by any means, electronic or mechanical, including photocopying and recording, for any purpose, without the express written permission of **M/A-COM, Inc.**

TABLE OF CONTENTS

	<i>Page</i>
1 REGULATORY AND SAFETY INFORMATION	6
1.1 SAFETY CONVENTIONS.....	6
2 DESCRIPTION	7
3 CIRCUIT ANALYSIS.....	8
3.1 PANEL CONTROL BOARD	8
3.2 SWITCH CIRCUIT.....	9
3.3 REMOTE INTERFACE ADAPTOR.....	9
4 DISASSEMBLY AND RE-ASSEMBLY PROCEDURE.....	11
4.1 LOCAL (FRONT MOUNT) DISASSEMBLY.....	11
4.1.1 Reassembly	16
4.2 REMOTE (TRUNK MOUNT) UNIT	17
4.2.1 Reassembly	18
4.2.2 Torque Values and Sequence.....	19
5 ORION CONTROL UNIT TEST	20
6 TECHNICAL ASSISTANCE.....	21
7 IC DATA	22
8 OUTLINE DIAGRAMS	29
9 REPLACEABLE PARTS	33
10 ASSEMBLY DIAGRAMS.....	33
11 PARTS LIST.....	48
11.1 CONTROL UNIT.....	48
11.2 PANEL CONTROL	49
11.3 SWITCH CIRCUIT.....	52
11.4 REMOTE INTERFACE ADAPTOR.....	55
12 PRODUCTION CHANGE DATA	56
13 INTERCONNECTION DIAGRAMS.....	59
14 SCHEMATIC DIAGRAMS	63

TABLE OF TABLES

Table 9-1: Remote Scan Model KRY 101 1632/12 (PL: CMC-556 BRC).....	36
Table 9-2: Remote System Model KRY 101 1632/14 (PL: CMC-556 MRC).....	39
Table 9-3: Local Scan Model KRY 101 1632/11 (PL: CMC-556 BLC)	43
Table 9-4: Local System Model KRY 101 1632/13 (PL: CMC-556 MLC).....	46

TABLE OF FIGURES

Figure 2-1: Scan Model Control Unit.....	7
Figure 2-2: System Model Control Unit.....	7
Figure 3-1: Block Diagram.....	10
Figure 4-1: M7100/JAGUAR 725M.....	11
Figure 4-2: Orion.....	11
Figure 4-3: M7100/JAGUAR 725M.....	12
Figure 4-4: Orion.....	12
Figure 4-5: M7100/JAGUAR 725M.....	12
Figure 4-6: Orion.....	12
Figure 4-7: M7100/JAGUAR 725M Control Unit.....	13
Figure 4-8: Orion Control unit	13
Figure 4-9: M7100/JAGUAR Control Unit	14
Figure 4-10: Orion Control Unit.....	14
Figure 4-11: Local (Front Mount) Control Unit.....	16
Figure 4-12: Rear Cover Torque Sequence (Local)	17
Figure 4-13: Local (Front Mount) Control Unit.....	19
Figure 4-14: Rear Cover Torque Sequence (Remote)	19
Figure 5-1: Access Control Unit Test Mode	20
Figure 7-1: IC101 Positive Voltage Regulator (TA78L05F)	22
Figure 7-2: IC102 8 Bit Shift Register (MC74HC595AF).....	23
Figure 7-3: IC201 Dual Operational Amplifier (NJM3404M).....	24
Figure 7-4: IC202 EEPROM (AT24C04N-10SI).....	24
Figure 7-5: IC203 Microcomputer (HD6433308RC28F).....	25
Figure 7-6: IC204 RS-485 Transceiver (DS75176BM)	26
Figure 7-7: IC205 Bilateral Switch (SC14S66F)	26
Figure 7-8: IC206 System Reset (PST575CMT)	27
Figure 7-9: IC207 Positive Voltage Regulator (NJM7805A).....	27
Figure 7-10: IC208 Positive Voltage Regulator (NJM7809A).....	28
Figure 7-11: IC209 VFC Controller (M66004FP)	28
Figure 7-12: IC210, 211 Photocoupler (PC356T).....	29
Figure 8-1: Panel Control CMC-638C Component Side.....	29
Figure 8-2: Panel Control CMC-638C Solder Side.....	30
Figure 8-3: Remote Interface Adaptor NQZ-4882C Component Side.....	30
Figure 8-4: Remote Interface Adaptor NQZ-4882C Solder Side.....	30
Figure 8-5: Switch Circuit CDF-368MC Component Side.....	31
Figure 8-6: Switch Circuit CDF-368MC Solder Side	31
Figure 8-7: Switch Circuit CDF-368BC Component Side.....	32
Figure 8-8: Switch Circuit CDF-368BC Solder Side	32
Figure 10-1: Remote Scan Model KRY 101 1632/12 (CMC-556 BRC, Sh. 2)	33
Figure 10-2: Remote Scan Model KRY 101 1632/12 CMC-556 BRC, Sh. 1).....	34
Figure 10-3: Remote Scan Model KRY 101 1632/12 CMC-556 BRC, Sh. 3).....	35
Figure 10-4: Remote System Model KRY 101 1632/14 (CMC-556 MRC, Sh. 2)	37
Figure 10-5: Remote System Model KRY 101 1632/14 (CMC-556 MRC, Sh. 1)	37
Figure 10-6: Remote System Model KRY 101 1632/14 (CMC-556 MRC, Sh. 3)	38
Figure 10-7: Local Scan Model KRY 101 1632/11 & KRY 101 1632/17 (CMC-556 BLC, Sh. 2)	41
Figure 10-8: Local Scan Model KRY 101 1632/11 & KRY 101 1632/17 (CMC-556 BLC, Sh. 1)	41
Figure 10-9: Local Scan Model KRY 101 1632/11 & KRY 101 1632/17 (CMC-556 BLC, Sh. 3)	42
Figure 10-10: Local System Model KRY 101 1632/13 & KRY 101 1632/19 (CMC-556 MLC, Sh. 2).....	44
Figure 10-11: Local System Model KRY 101 1632/13 & KRY 101 1632/19 (CMC-556 MLC, Sh. 1).....	44

Figure 10-12: Local System Model KRY 101 1632/13 & KRY 101 1632/19 (CMC-556 MLC, Sh. 3)	45
Figure 13-1: Control Unit (Scan Local) (ED00-CMD-556BLC)	59
Figure 13-2: Control Unit (Scan Remote) (ED00-CMD-556BRC)	60
Figure 13-3: Control Unit (System Local) (ED00-CMD-556MLC)	61
Figure 13-4: Control Unit (System Remote) (ED00-CMD-556MRC)	62

1 REGULATORY AND SAFETY INFORMATION

1.1 SAFETY CONVENTIONS

The following conventions may be used in this manual to alert the user to general safety precautions that must be observed during all phases of operation, service, and repair of this product. Failure to comply with these precautions or with specific warnings elsewhere in this manual violates safety standards of design, manufacture, and intended use of the product. M/A-COM, Inc. assumes no liability for the customer's failure to comply with these standards.



The **WARNING** symbol calls attention to a procedure, practice, or the like, which, if not correctly performed or adhered to, could result in personal injury. Do not proceed beyond a **WARNING** symbol until the conditions identified are fully understood or met.



The **CAUTION** symbol calls attention to an operating procedure, practice, or the like, which, if not performed correctly or adhered to, could result in a risk of danger, damage to the equipment, or severely degrade the equipment performance.



The **NOTE** symbol calls attention to supplemental information, which may improve system performance or clarify a process or procedure.



The **ESD** symbol calls attention to procedures, practices, or the like, which could expose equipment to the effects of **E**lectro-**S**tatic **D**ischarge. Proper precautions must be taken to prevent ESD when handling circuit modules.

2 DESCRIPTION

The Control Unit is available as a **SCAN** or **SYSTEM** model (see Figure 2-1 and Figure 2-2). Each control unit consists of:

- Switch Circuit A1
- Panel Control A2
- Interconnecting Circuit PC1
- Interconnecting Circuit PC2

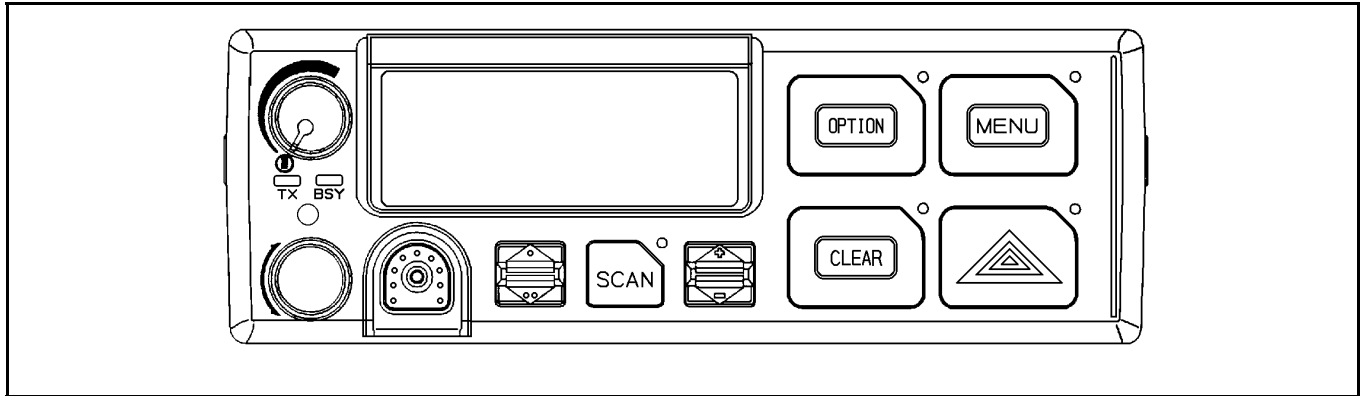

Figure 2-1: Scan Model Control Unit

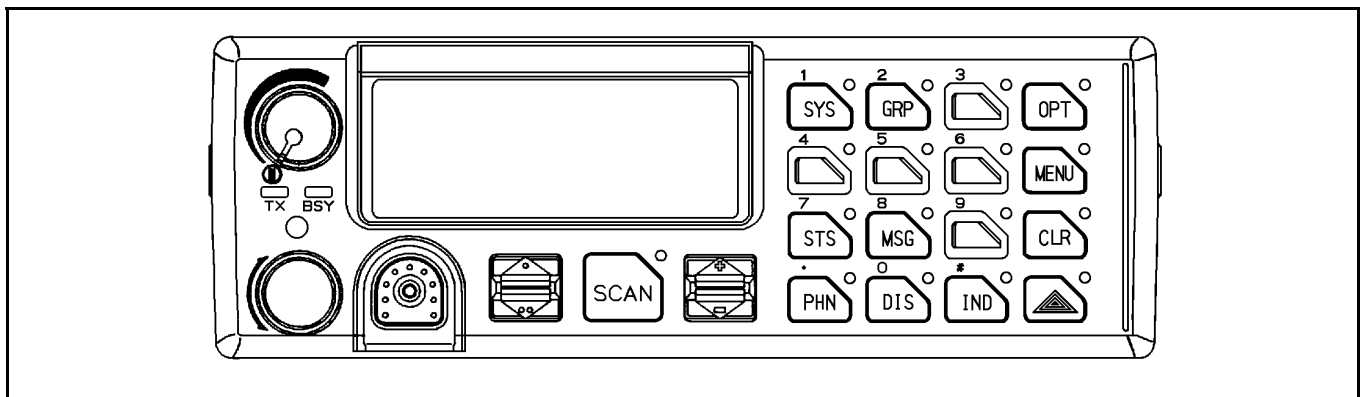

Figure 2-2: System Model Control Unit

The Panel Control and Switch Circuit boards are housed in the Control Unit Assembly. The Panel Control board interfaces and processes signals between the Switch board and the rest of the radio unit. The Switch Board contains the control switches and indicators used to communicate information between the radio and the operator.

The control unit for a locally connected control unit (front mount installation) connects directly to the radio circuit boards through the **Local Control Connector (LCC)**. This connection uses interconnect board PC2 (Refer to the Local Interconnect Diagrams).

The control unit for a remotely connected control unit (trunk mount installation) also uses PC2 but in addition incorporates a **Remote Interface Adaptor (RIA)**. The **RIA (NQZ-4882C)** connects to the back of the control unit on the PC2 and provides the interface for accessories through the **OPTION (OPT)**

connector and the **Remote Control Connector (RCC)** connector. (Refer to the Remote Interconnect Diagrams)

Switch Circuit A1 (CDF-368BC for the **SCAN** model and CDF-368MC for the **SYSTEM** model) plugs into the Panel Control A2 (CMC-638C). These Switch Circuits provide a microphone connector and all push switch combinations for **SCAN** and **SYSTEM** control units.

The Rotary Selector switch (S1) and Power/Volume control (S2) connect to the Panel Control circuit (A1) through circuit board connector PC1.

3 CIRCUIT ANALYSIS

3.1 PANEL CONTROL BOARD

The Panel Control Board interfaces between the Switch Board, the Logic Board and the microphone. The board contains microcontroller IC203, EEPROM IC202, **Vacuum Fluorescent Display (VFD)**, VFD driver IC209, voltage regulators IC207 and IC208, power reset IC206, voltage level converter, light sensor, interface circuitry and back lighting control.

Power enters the board through connector J203 from the Logic Board. Switched A+ (SW A+) is applied to two voltage regulators IC207 and IC208. Regulator IC207 provides +5 VDC to power the logic circuitry, and IC208 provides +9 VDC for the backlight LED indicators and voltage converter (refer to Figure 3-1). Power-on reset is provided by the 5-volt regulator **RESET** line and is applied to the **RESET** input of microcontroller IC203 on Pin 1. Microphone connections are made to the board through connector J202. No audio processing is performed on the Panel Control Board and the microphone lines **MIC HI** and **ALO** are passed to the Logic Board through connector J203.

Signal lines from the operating control switches, **OPT**, **MENU**, etc., on the Switch Board enter the Panel Control Board at J202. These active low lines are diode protected by diodes CD204 through CD216 and pulled up to 5 volts by resistors R233 through R240. All lines connect directly to microcontroller IC203.

The LED backlight levels of the operating controls are set by current transistor switches TR202 and TR203. These switches complete the path from +9 volts, through the backlight diodes on the Switch Board and back to ground. Return current from the backlight LED's flows into the Panel Control Board at J202, Pin 9 (**BKLT**) and is tied to the current switches through resistors R220 and R221. The **LGHT-PWR1** and **LGHT-PWR2** lines from the microcontroller IC203, Pins 57 and 58, are connected to switch drivers TR204 and TR205. Depending on the levels of **LGHT-PWR1** and **LGHT-PWR2**, the two current switches are turned on or off in different combinations, effectively placing different values of resistor (R220 and R221) in the return path. Four different backlight levels are possible.

Photosensor (light sensor) TR201 and associated circuitry (IC201) provides a signal to the microcontroller (IC203) that indicates high or low ambient light levels. This signal is used by the microcontroller to control the backlight levels (LEDs and VFD).

The **RS485+** and **RS485-** lines are connected to the **UART** of the microcontroller through RS485 line driver/receiver. The **RQST** line is bi-directional and provides an indication that data is present on the **RS485** serial data bus. As an output, the line is pulled LOW to indicate that the Control Unit (**CU**) wishes to transmit a data message to another terminal. As an input a LOW state indicates a data message is to be received by the control unit.

The microcontroller clock frequency is set by crystal X201 which is connected to IC203, pins 2 and 3.

The EEPROM has a storage capacity of 512 x 8 bits.

The VFD is a sixteen digit, dot matrix display. Serial data to be displayed by the VFD comes from the microcontroller bus and is applied to IC209, Pin 16. The clock pulse and CS signal are applied to the VFD driver at pins 15 (**SCK**) and 14 (**CS**). The VFD has 6 levels of backlight control internal to the module.

3.2 SWITCH CIRCUIT

The Switch Circuit Board contains the keypad function LED's, bottom backlight LED's and control switches. This board interfaces to the Panel Control Board through connector J201.

Back lighting is provided for the control switches **OPT**, **MENU**, etc. There are four backlight levels (including off) available. These levels are set on the Panel Control Board through the use of two current switches. The amount of current flowing from +9 VDC through the backlight diodes and returning to ground (**BKLT**) is controlled by the settings of the current switches on the Panel Control Board.

The operating control switches on the front panel are all tied to a bus through connector J101 to the Panel Control Board. The switch states are read by the microcontroller on the Panel Control Board.

A shift register is used to receive the serial data signal and provide a parallel output used to drive the keypad function LED's.

3.3 REMOTE INTERFACE ADAPTOR

The **Remote Interface Adaptor (RIA)** Board interfaces between the Panel Control Board, the option connector and the Remote Control Cable through the RCC connector. The RIA board contains the **LCC**, **ORCC** and **RCC** connectors. No active circuitry is on the RIA board.

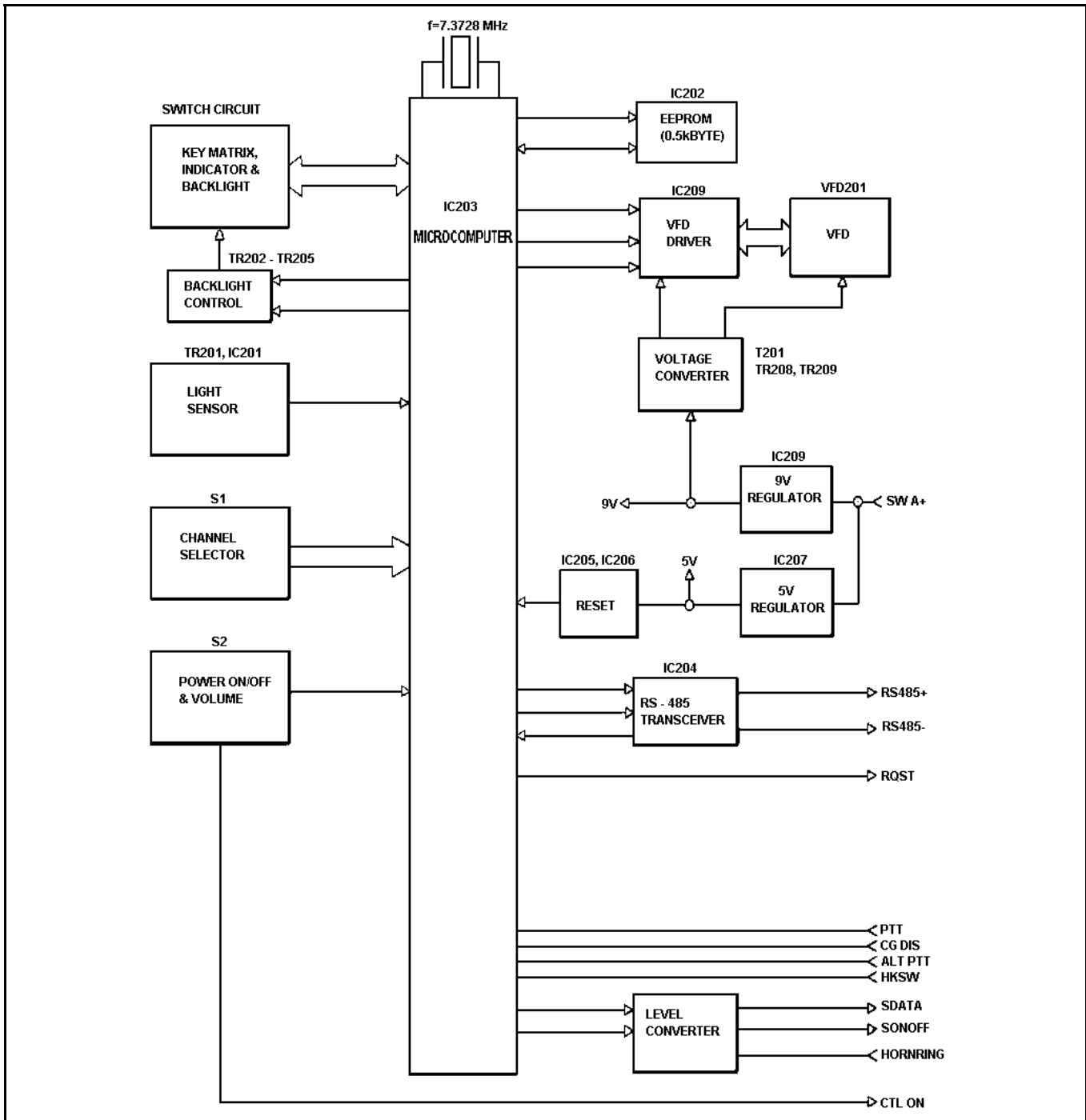

Figure 3-1: Block Diagram

4 DISASSEMBLY AND RE-ASSEMBLY PROCEDURE

This section provides the information and procedures recommended for disassembling and re-assembling the control unit.



CAUTION – This control unit contains components that can be damaged by the effects of Electrostatic Discharge (ESD). Be sure to use proper precautions when disassembling this equipment.

This procedure is intended to enable the installation of replacement parts and kits available from M/A-COM's Customer Resource Center (customerfocus@tycoelectronics.com).

4.1 LOCAL (FRONT MOUNT) DISASSEMBLY

1. Remove control head from the radio by loosening the two captive TORX® 10 screws from the bottom of the radio.

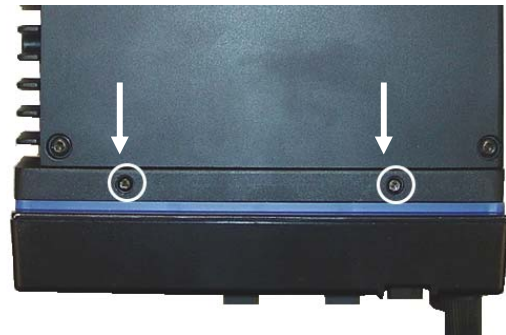

Figure 4-1: M7100/JAGUAR 725M



Figure 4-2: Orion

2. Detach control unit from the radio, being careful not to damage the flex cable.

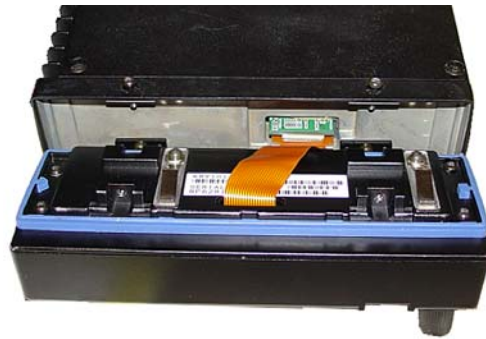

Figure 4-3: M7100/JAGUAR 725M

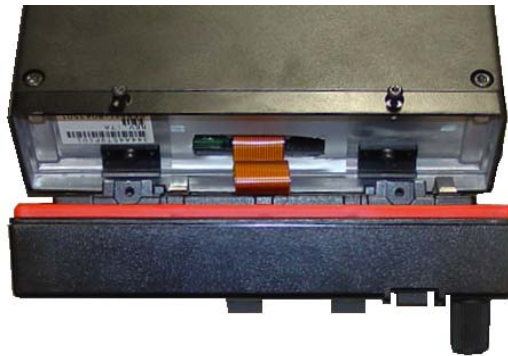

Figure 4-4: Orion

3. Disconnect the flex cable from the radio.
 - a. For an M7100/JAGUAR 725M radio, unplug the flex cable (see Figure 4-5).
 - b. For an ORION radio, use a small flat blade screw driver to disengage the ZIF connector and remove the flex cable (see Figure 4-6).

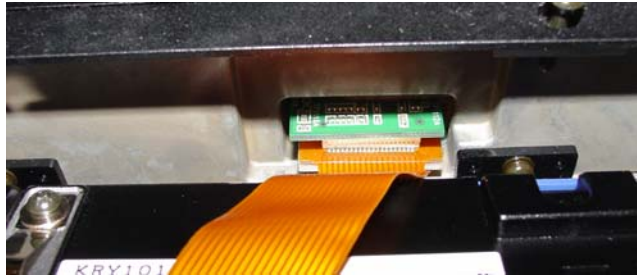

Figure 4-5: M7100/JAGUAR 725M

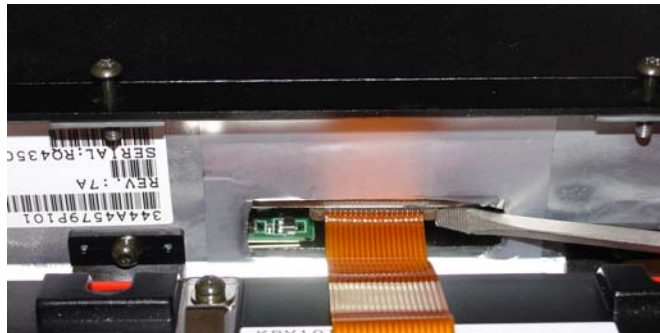

Figure 4-6: Orion



Figure 4-7: M7100/JAGUAR 725M Control Unit

4. Using a TORX 10 driver, loosen the four (4) captive screws in the back of the control unit.



Figure 4-8: Orion Control unit

5. Flip open back cover being careful not to damage the flex cable or pull it loose from the Panel Control Board. If disassembling an M7100/JAGUAR 725M control unit (see Figure 4-7 and Figure 4-9), be aware that the connector on the flex cable WILL NOT fit through the slot in the rear cover. The cable will have to be disconnected from the Panel Control board first.

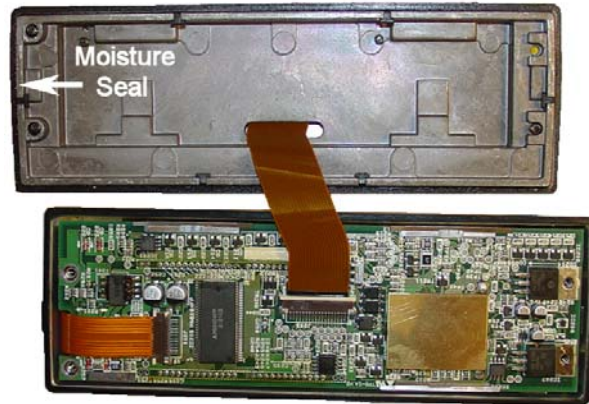

Figure 4-9: M7100/JAGUAR Control Unit

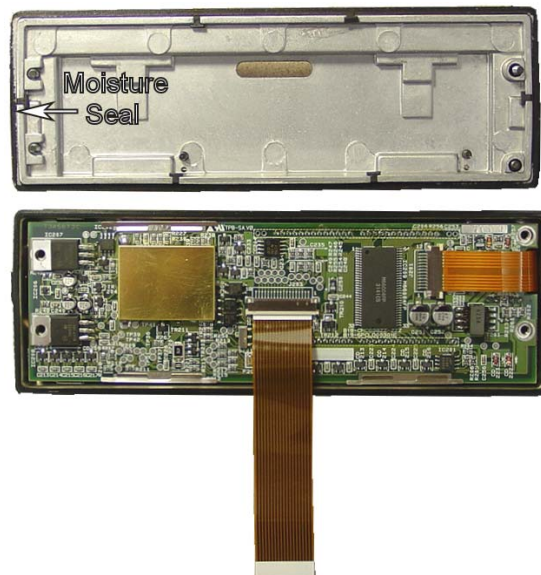
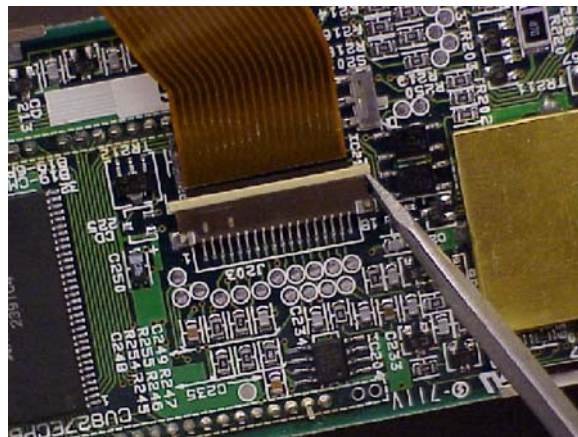
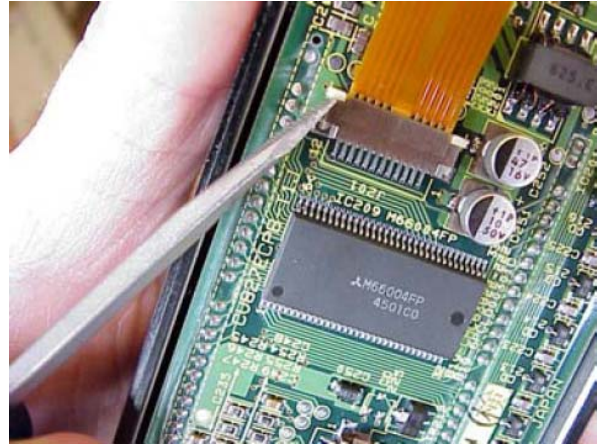

Figure 4-10: Orion Control Unit

6. Insert a small flat-blade screwdriver under the movable part of connector J203 on the Panel Control board and gently disengage the locking tab from each side of the connector. Remove the flex cable.



7. Insert a small flat-blade screwdriver under the movable part of connector J201 on the Panel Control board and gently disengage the locking tab from each side of the connector. Remove the flex cable.



J201 and J203 are Zero Insertion Force (ZIF) connectors and are fragile. To avoid damaging the connector, do not apply too much pressure to the moveable part of the connector when opening and closing it.

8. Gently pry the edge of the Panel Control board to unplug it from the switch circuit board. Lift the panel control board out of the casting

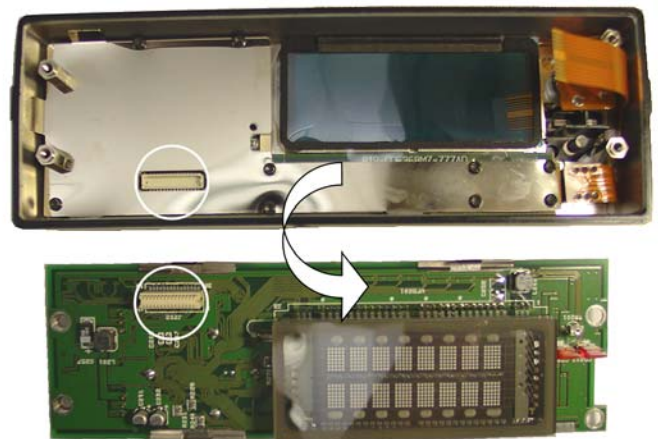

9. Using a TORX 8 driver, remove the nine (9) screws from the shield plate and reinforced board. Using a 7/32" nut driver, remove the two (2) standoffs. Lift the shield plate and reinforced board out of the casting.



10. Lift the Switch Circuit board out of the casting.

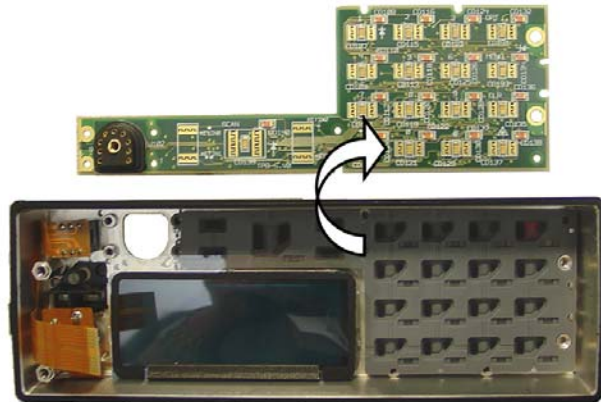

4.1.1 Reassembly

Follow all steps in reverse to reassemble the control unit, referring to Figure 10-9 and Figure 10-12 for torque values and sequence.

In addition:

1. Prepare the cover by ensuring that the black silicone gasket is properly in place and applying a small amount of silicone grease to the gasket.

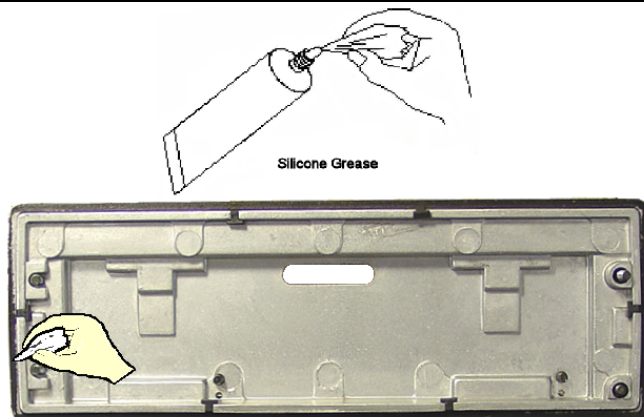

Figure 4-11: Local (Front Mount) Control Unit

2. Carefully wipe away any excess silicone grease with a lint-free cloth.



Ensure that no fibers of cloth remain on the gasket after the silicone is applied.

3. Re-install rear cover. Using a TORX 10 driver, torque the four (4) captive screws to 8 kg-cm (7 in-lb). Refer to Figure 4-12 for torque sequence (sequence is the same for ORION/M7100/JAGUAR 725M Control unit.)



Figure 4-12: Rear Cover Torque Sequence (Local)

4.2 REMOTE (TRUNK MOUNT) UNIT

The disassembly procedure for a Remote Control unit is identical to the Front Mount unit except for removal of the rear cover and removal of the Remote Interface Adapter.



The Remote Unit is the same for M7100, ORION, and JAGUAR 725M

<p>1. Loosen the four (4) captive screws in the back of the unit using a TORX 10 driver</p>	
<p>2. Lift off rear cover being careful not to damage the flex cable that runs from the Remote Interface Adapter to the Panel Control board.</p>	

3. Insert a small flat-blade screwdriver under the movable part of connector J2 on the Remote Interface Adapter and gently pry in the direction of the arrows. Remove the flex cable.

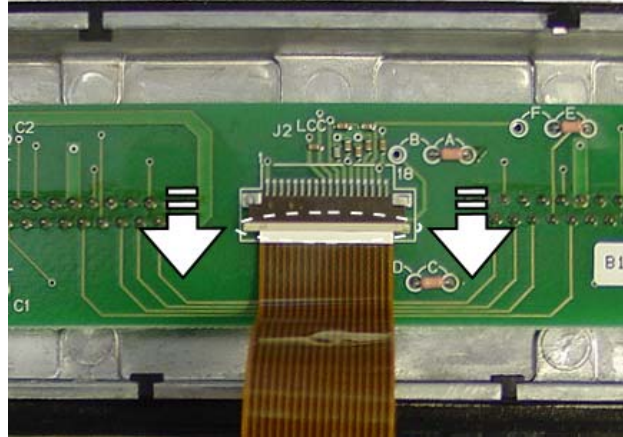

J2 is a Zero Insertion Force (ZIF) connector and is fragile. To avoid damaging the connector, do not apply too much pressure to the moveable part of the connector when opening and closing it.

4. To remove Remote Interface Adapter from rear cover, remove the four (4) standoffs from back cover.



4.2.1 Reassembly

Follow all steps in reverse to reassemble the control unit, referring to Figure 10-3 and Figure 10-6 for torque values and sequence.

In addition:

4. Prepare the rear cover by ensuring that the black silicone gasket is properly in place and applying a small amount of silicone grease to the gasket.

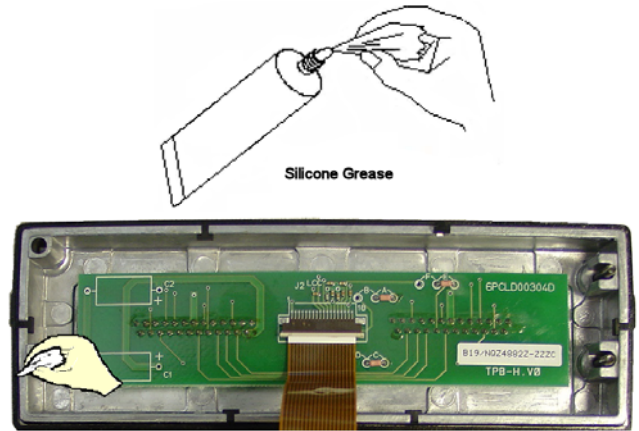

Figure 4-13: Local (Front Mount) Control Unit

5. Carefully wipe away any excess silicone grease with a lint-free cloth.



Ensure that no fibers of cloth remain on the gasket after the silicone is applied.

6. Re-install rear cover. Using a TORX 10 driver, torque the four (4) captive screws to 8 kg-cm (7 in-lb). Refer to Figure 4-14 for torque sequence (sequence is the same for ORION/M7100/JAGUAR 725M Control unit.)



Figure 4-14: Rear Cover Torque Sequence (Remote)

4.2.2 Torque Values and Sequence

Refer to Figure 10-3, Figure 10-6, Figure 10-9, and Figure 10-12 for torque values and sequences when reassembling control units.

5 ORION CONTROL UNIT TEST

The Orion Control Unit has a built-in test mode with the capacity to test the control unit's keypad, display, LEDs, knobs, and buttons. For this reason the Diagnostic Radio Code Power-Up Test Mode does not apply to the Orion radio. Use the following procedure to perform a control unit test.



In the control unit test mode, the control unit will not communicate with any network devices.

1. To Access the Orion Control Unit Test Mode, press the appropriate two (2) keys on the keypad simultaneously. See Figure 5-1.

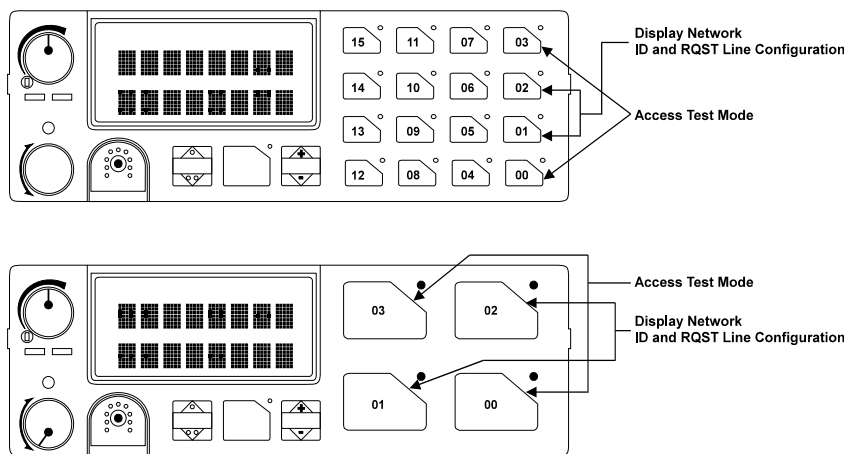



Figure 5-1: Access Control Unit Test Mode

2. Upon entering the control unit test mode, the following conditions should occur:
 - copyright information should be on the display
 - all keylights should be on
 - the BUSY, SCAN and TX LEDs should be on
3. Use the ramp control keys  to control the display intensity. Use the Scan + and Scan – keys  to control the backlight intensity.
4. Test the keys on the keypad by pressing each key. The keylight above each key should extinguish as the key is pressed.
5. After all the keylights are extinguished, the BUSY, SCAN, and TX LEDs should go out.
6. The volume, light intensity and rotary selector knob information along with software version should appear on the display.
7. Pressing keys **01** and **02** will display the control unit's network ID and RQST line configuration. Pressing the **01** and **02** keys will also result in the Federal SS2000 siren and lights interface to send out a two byte bit pattern.

End of control unit test procedure. To exit the control unit test mode, cycle power on the control unit.

6 TECHNICAL ASSISTANCE

The Technical Assistance Center's (TAC) resources are available to help with overall system operation, maintenance, upgrades and product support. TAC is the point of contact when answers are needed to technical questions.

Product specialists, with detailed knowledge of product operation, maintenance and repair provide technical support via a toll-free (in North American) telephone number. Support is also available through mail, fax and e-mail.

For more information about technical assistance services, contact your sales representative, or call the Technical Assistance Center directly at:

North America:	800-528-7711
International:	434-385-2400
FAX:	434-455-6712
e-mail:	tac@tycoelectronics.com

7 IC DATA

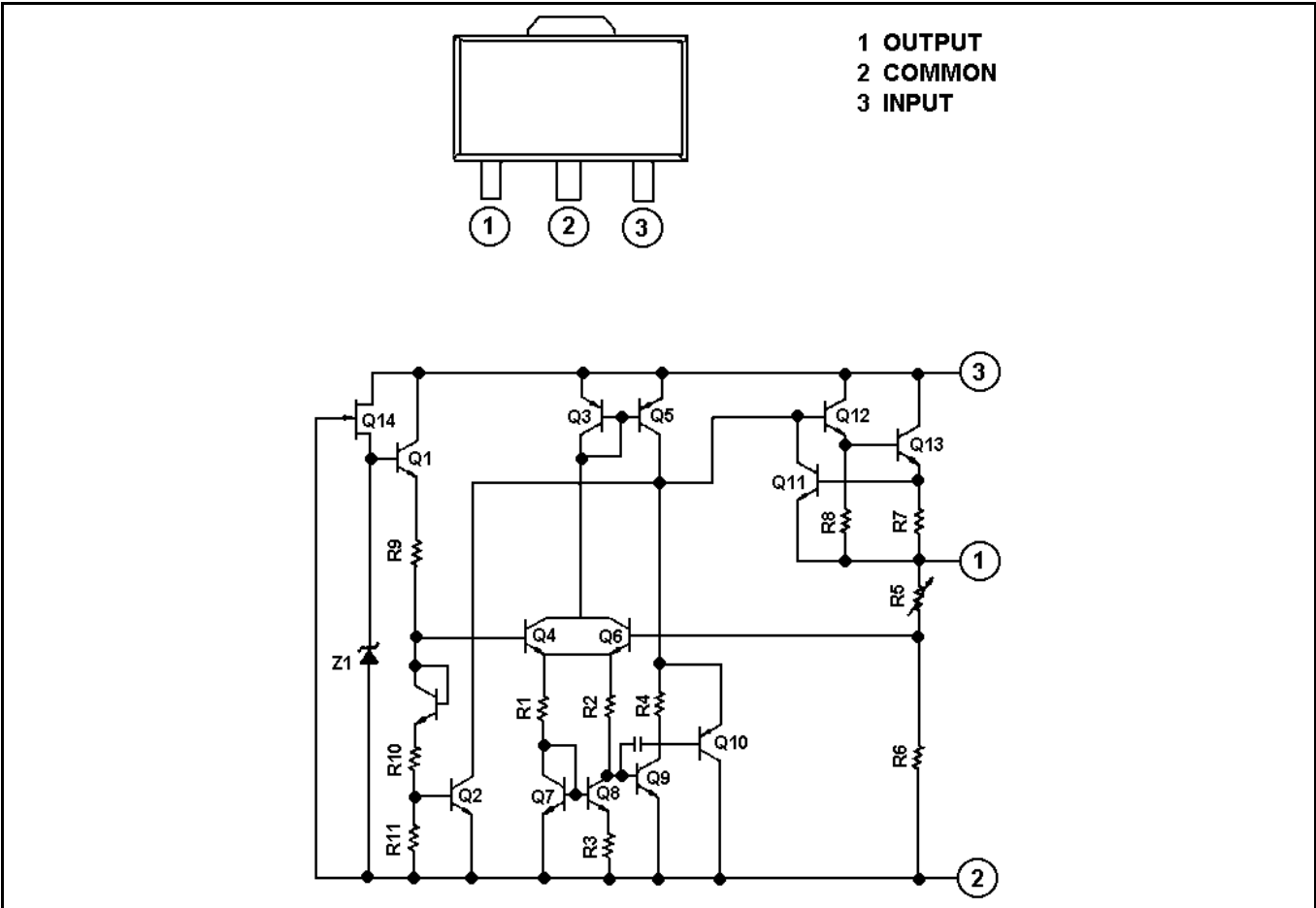

Figure 7-1: IC101 Positive Voltage Regulator (TA78L05F)

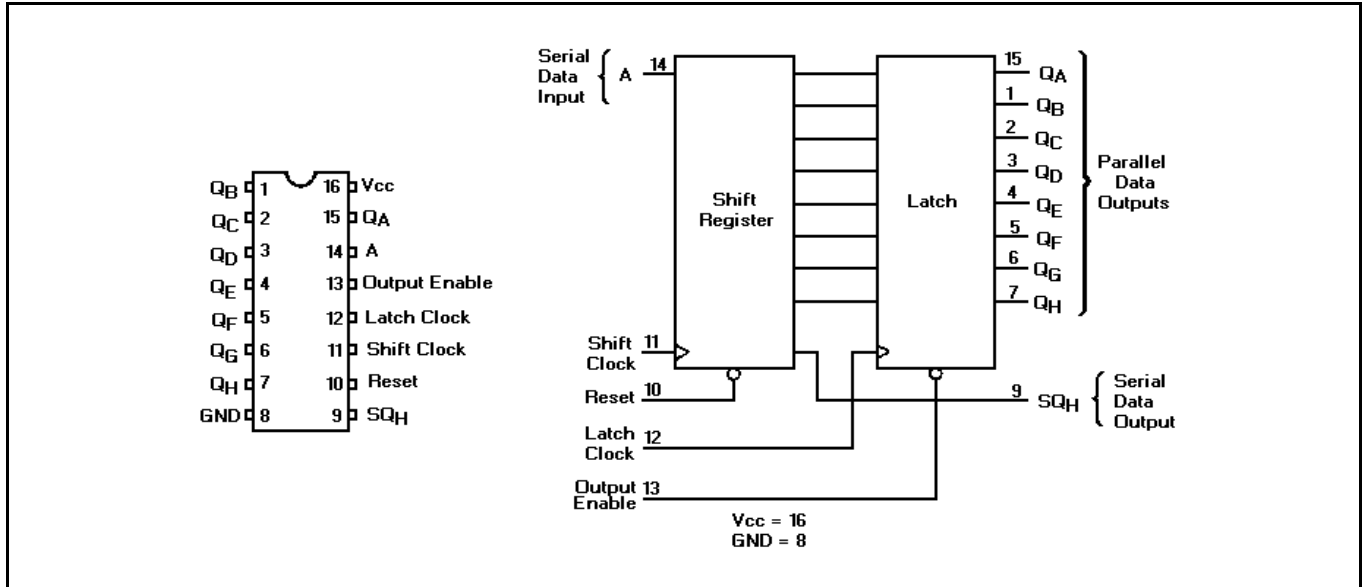

Figure 7-2: IC102 8 Bit Shift Register (MC74HC595AF)

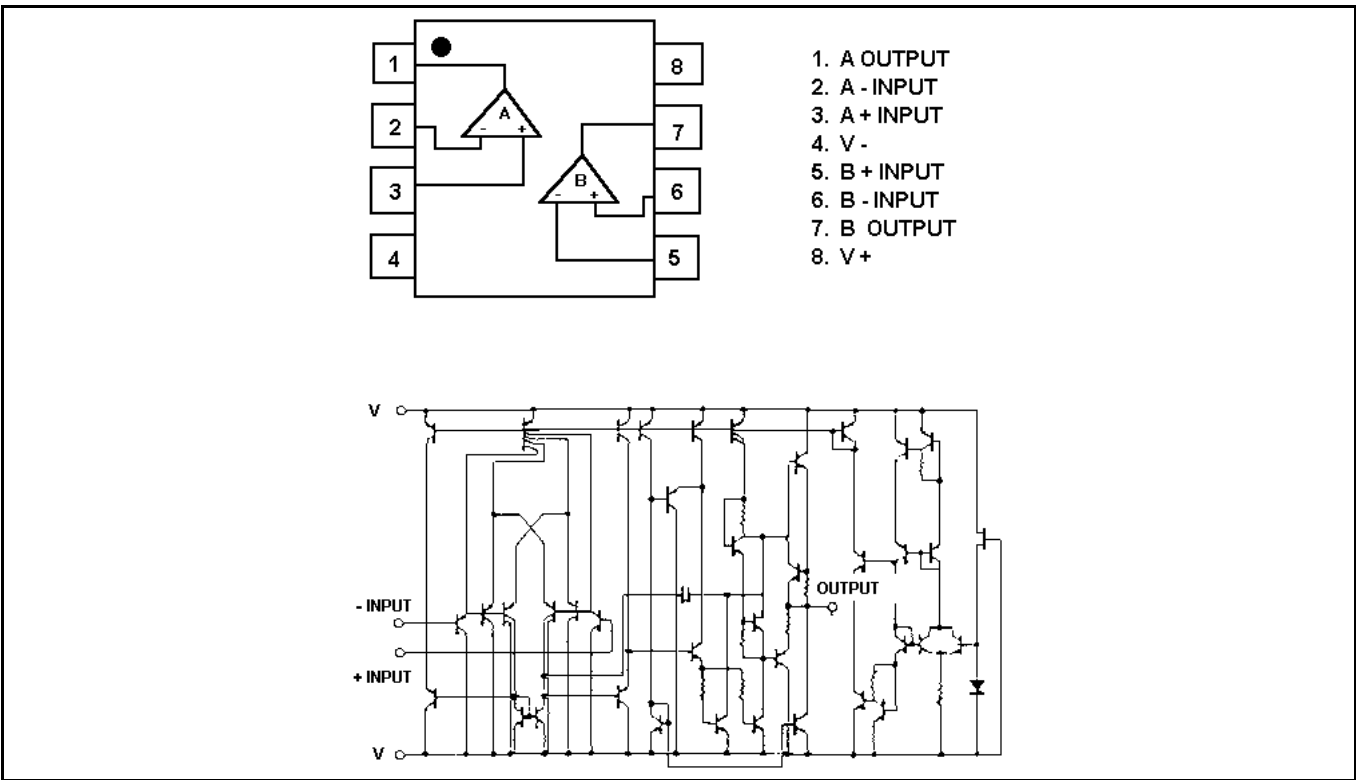

Figure 7-3: IC201 Dual Operational Amplifier (NJM3404M)

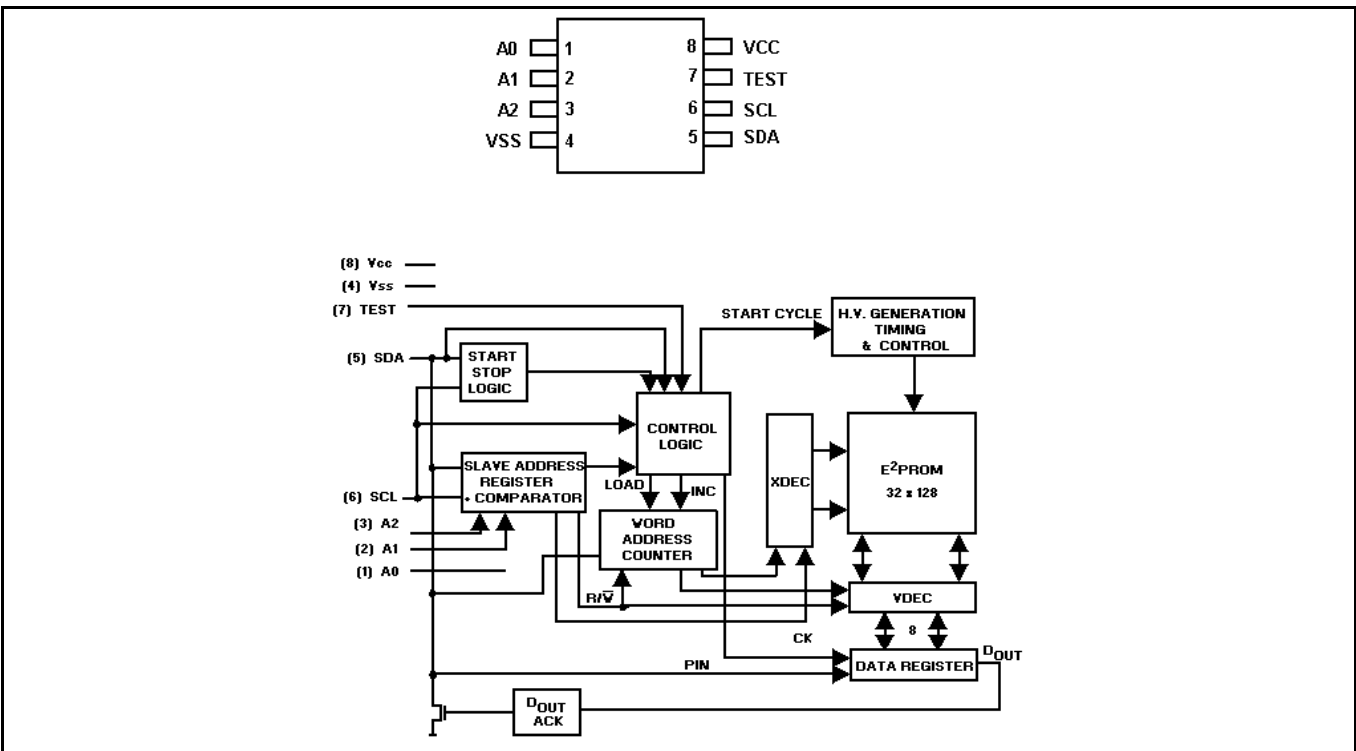

Figure 7-4: IC202 EEPROM (AT24C04N-10SI)

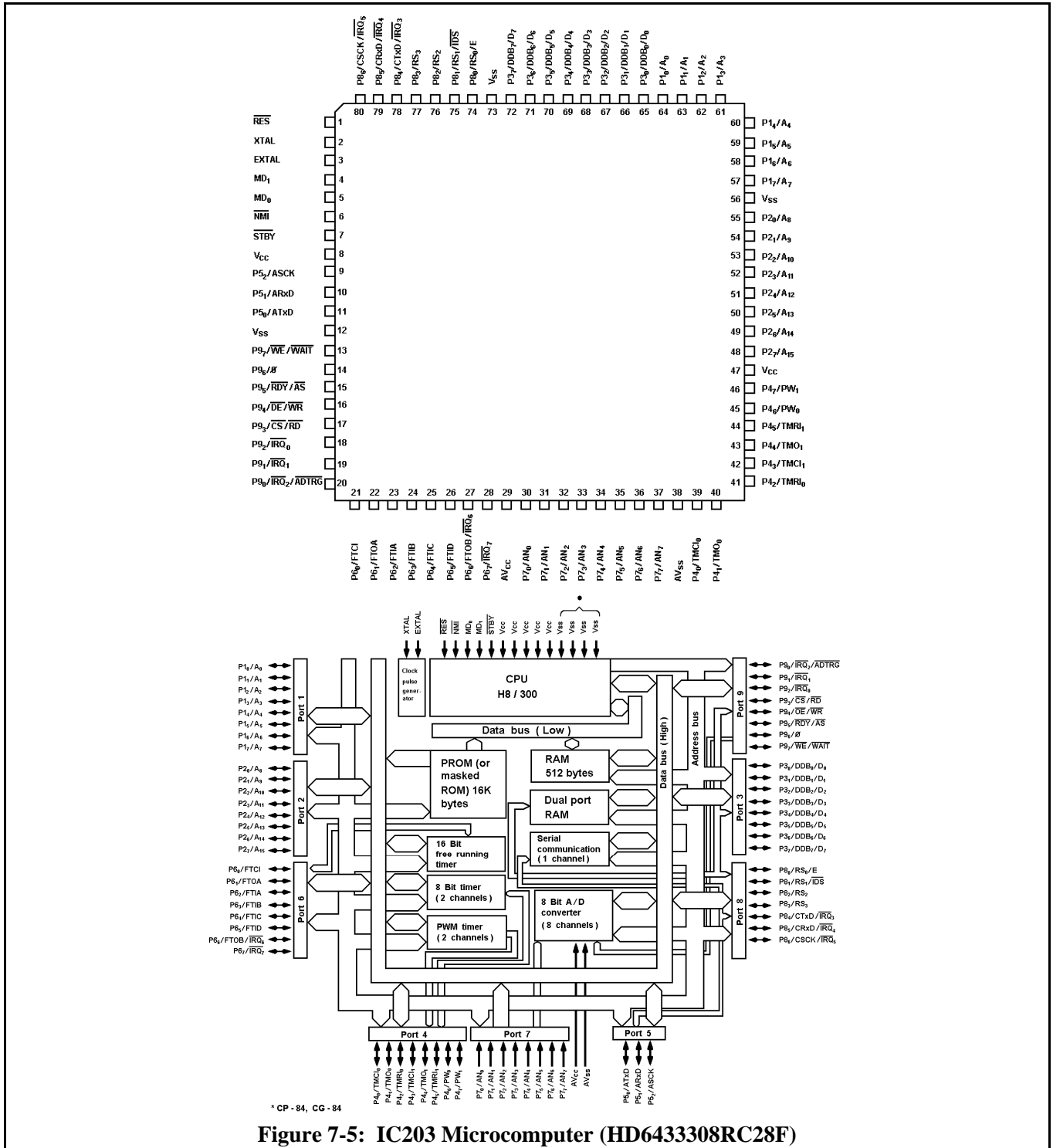

Figure 7-5: IC203 Microcomputer (HD6433308RC28F)

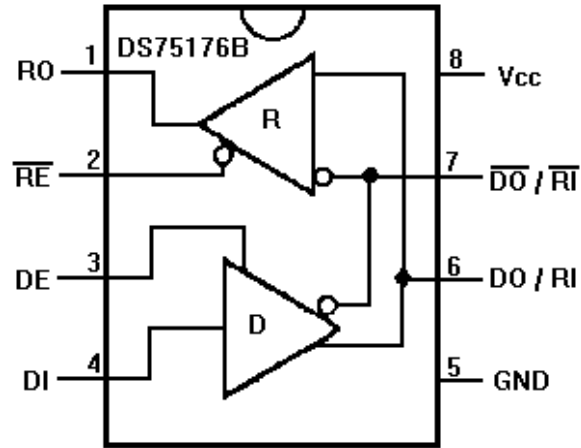

Figure 7-6: IC204 RS-485 Transceiver (DS75176BM)

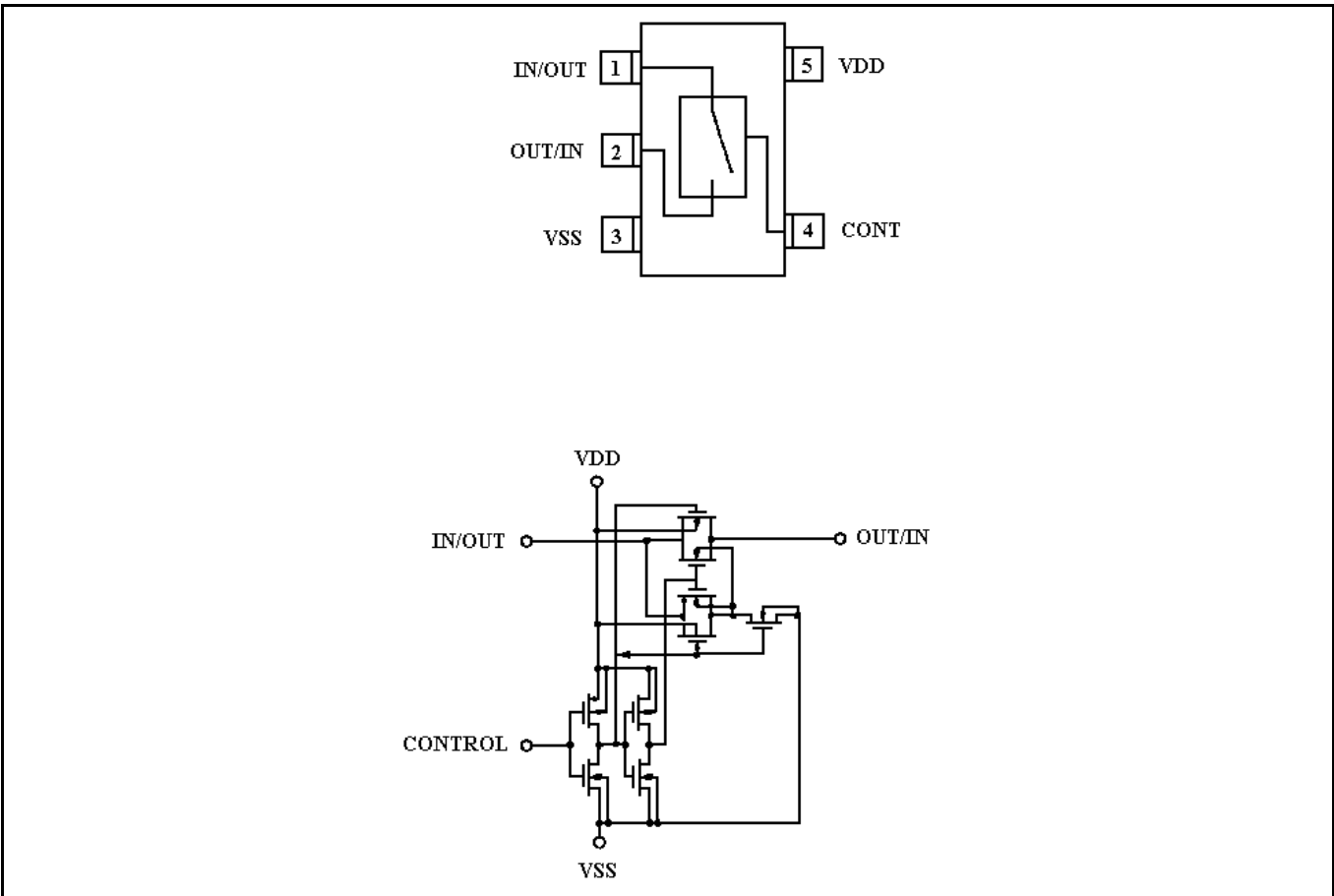

Figure 7-7: IC205 Bilateral Switch (SC14S66F)

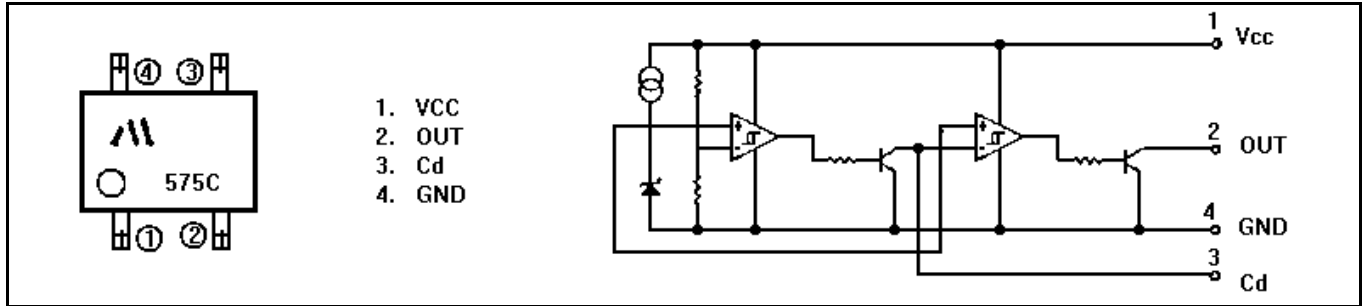

Figure 7-8: IC206 System Reset (PST575CMT)

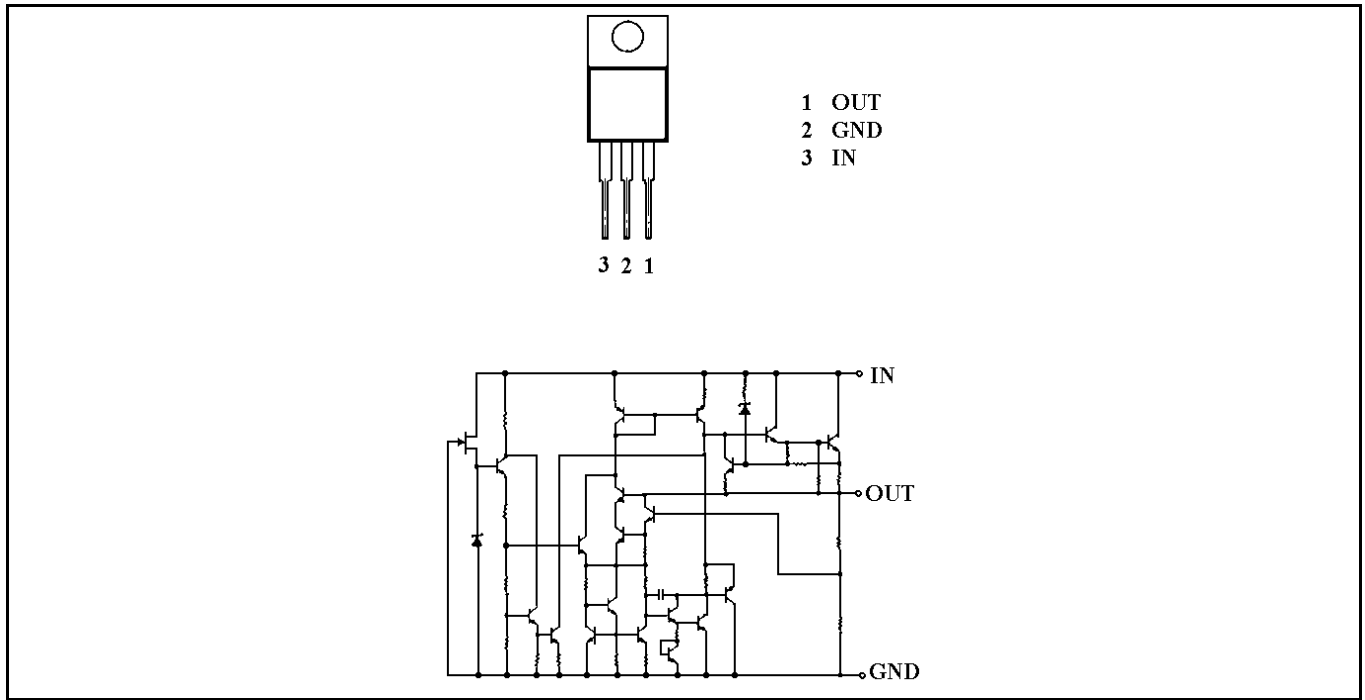

Figure 7-9: IC207 Positive Voltage Regulator (NJM7805A)

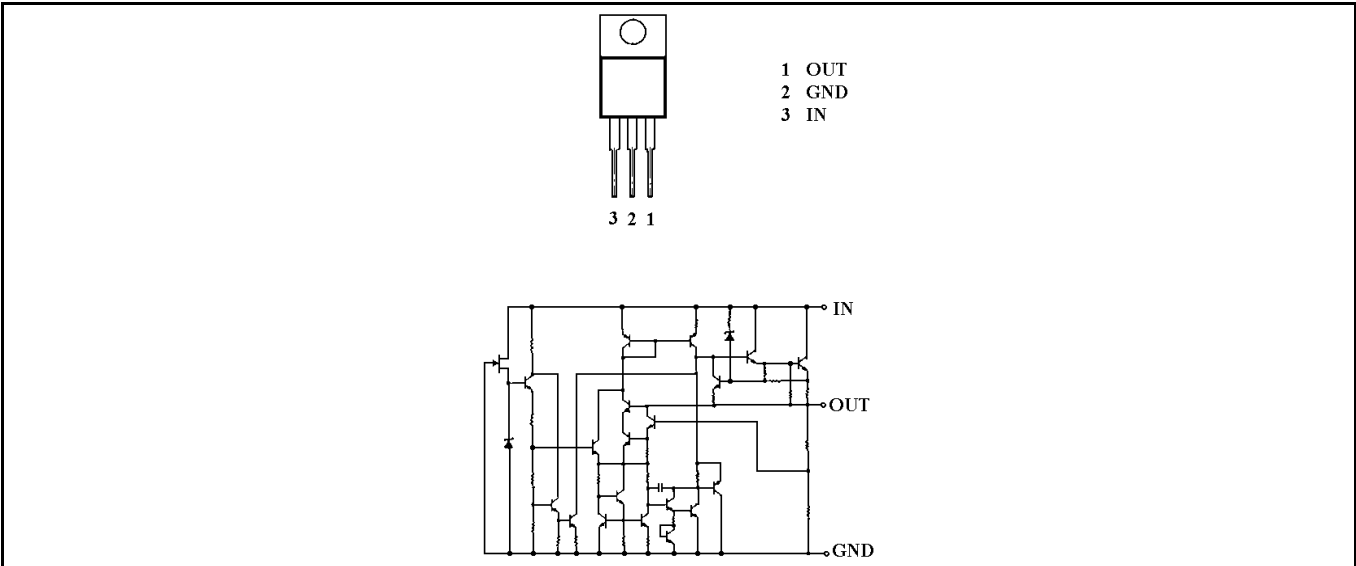

Figure 7-10: IC208 Positive Voltage Regulator (NJM7809A)

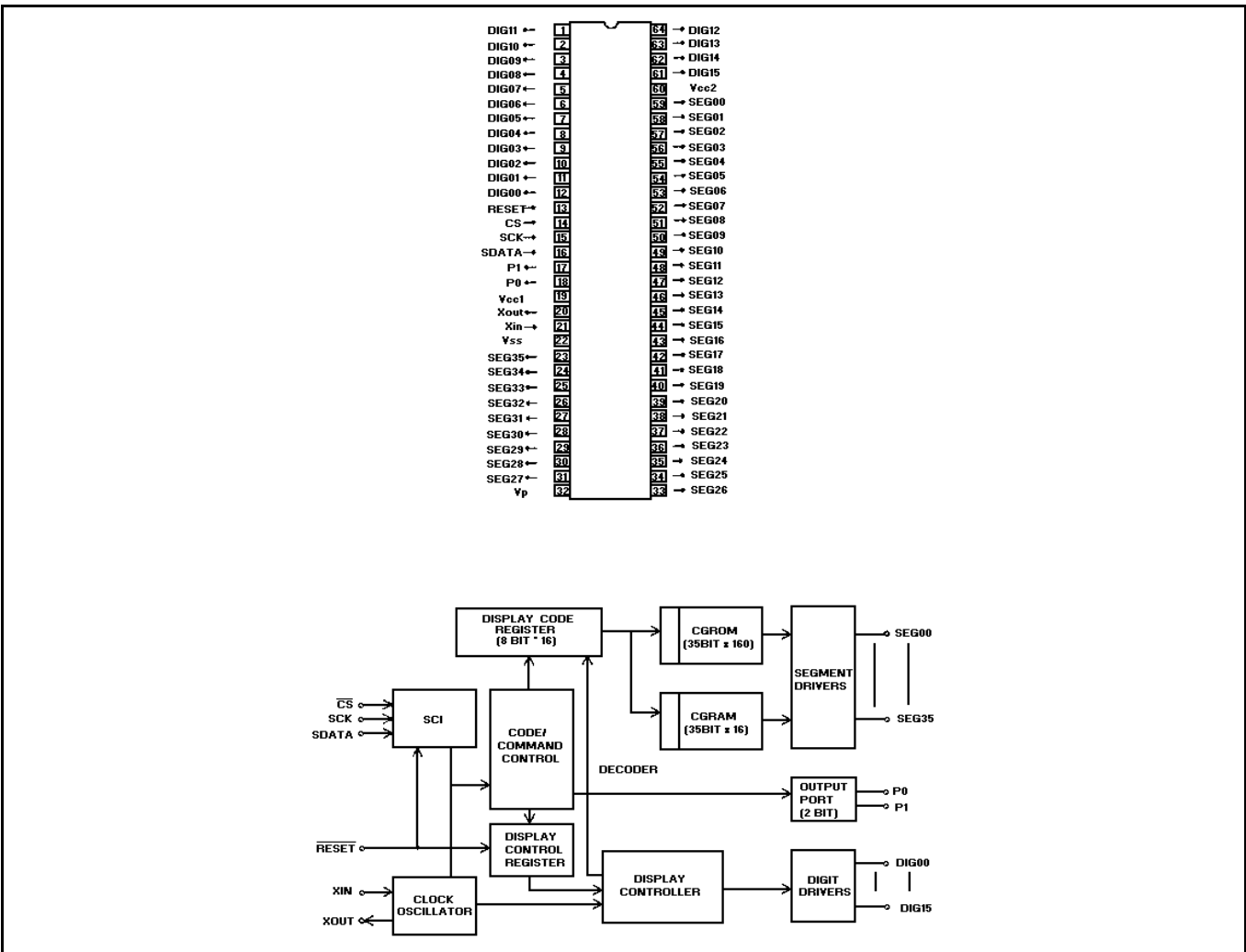

Figure 7-11: IC209 VFC Controller (M66004FP)

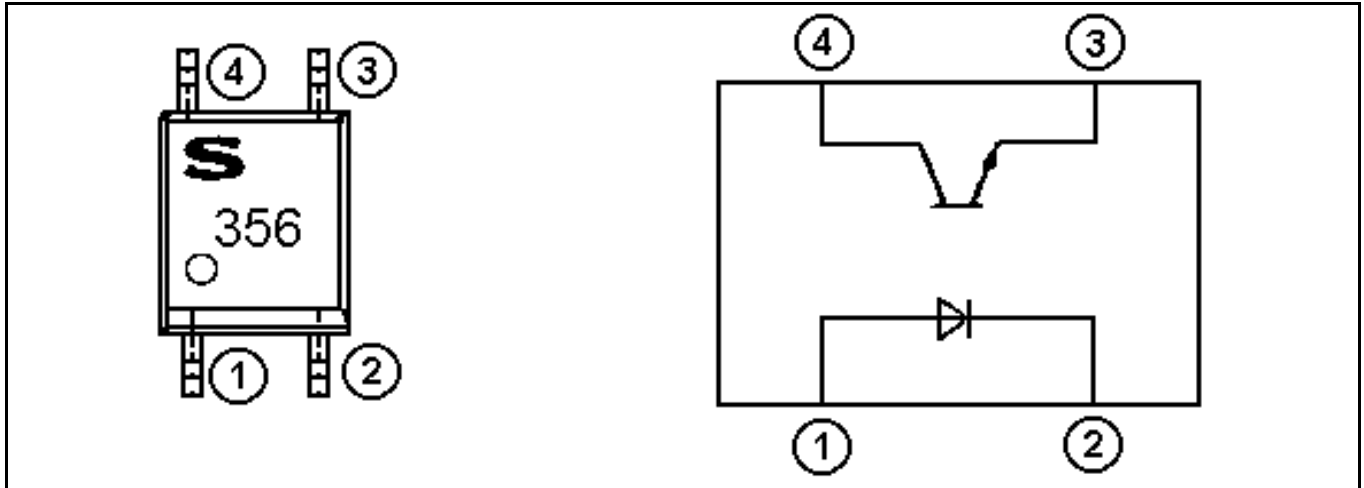

Figure 7-12: IC210, 211 Photocoupler (PC356T)

8 OUTLINE DIAGRAMS

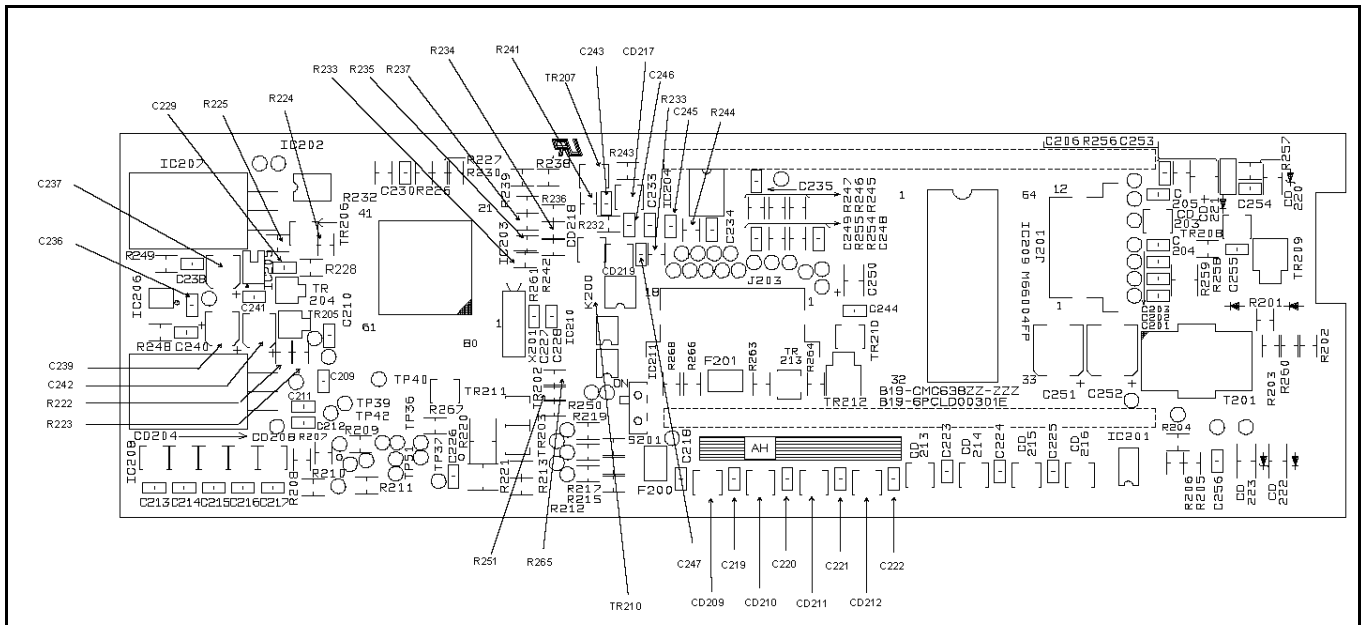

Figure 8-1: Panel Control CMC-638C Component Side

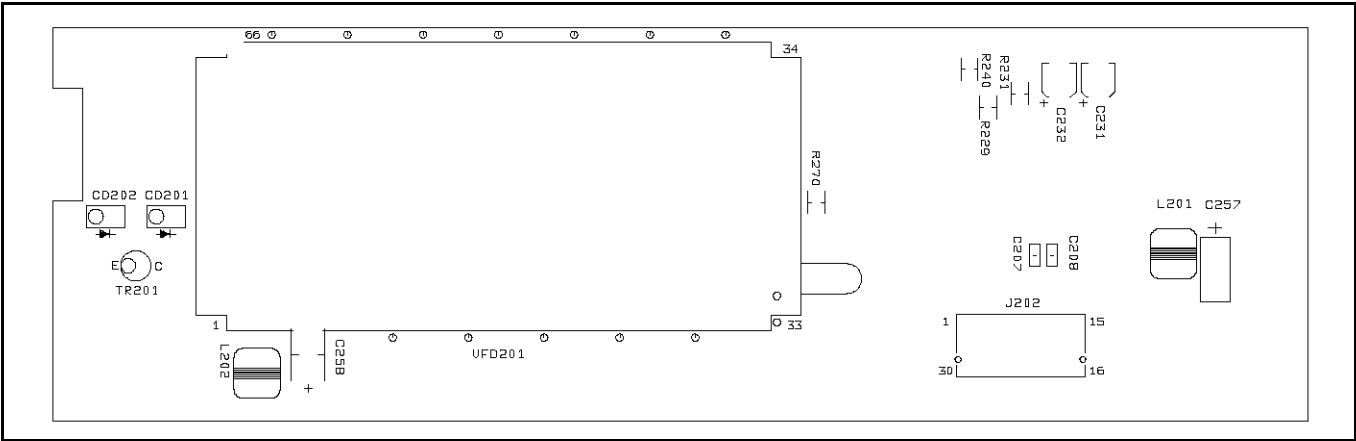

Figure 8-2: Panel Control CMC-638C Solder Side

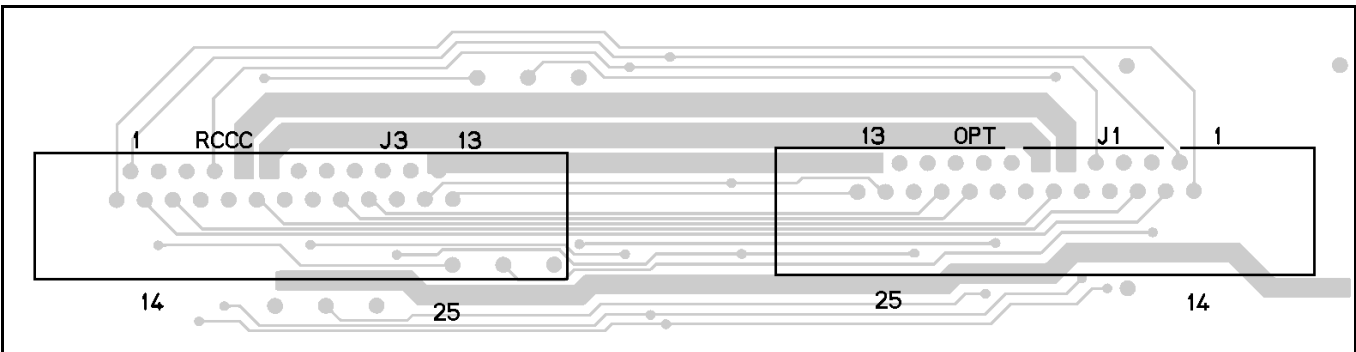

Figure 8-3: Remote Interface Adaptor NQZ-4882C Component Side

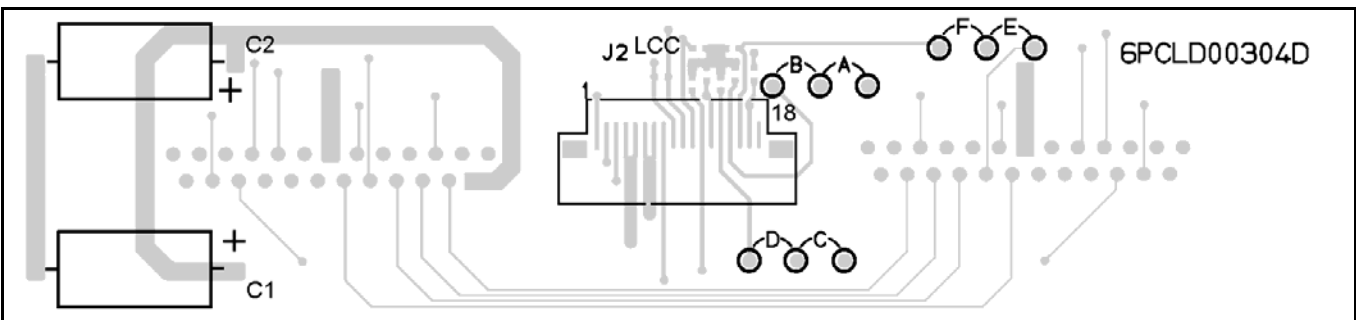

Figure 8-4: Remote Interface Adaptor NQZ-4882C Solder Side

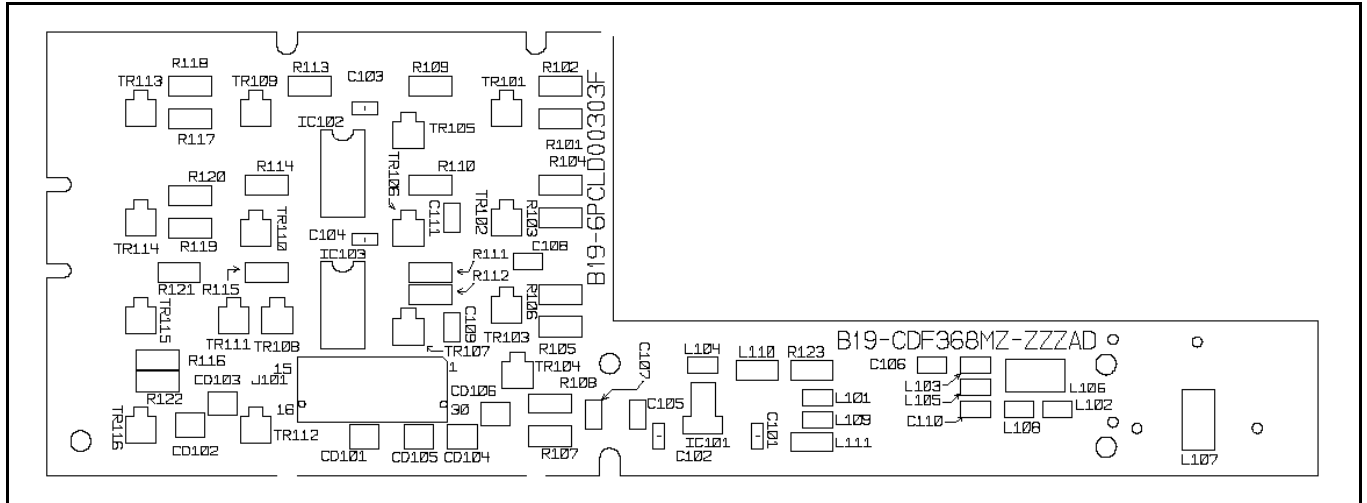

Figure 8-5: Switch Circuit CDF-368MC Component Side

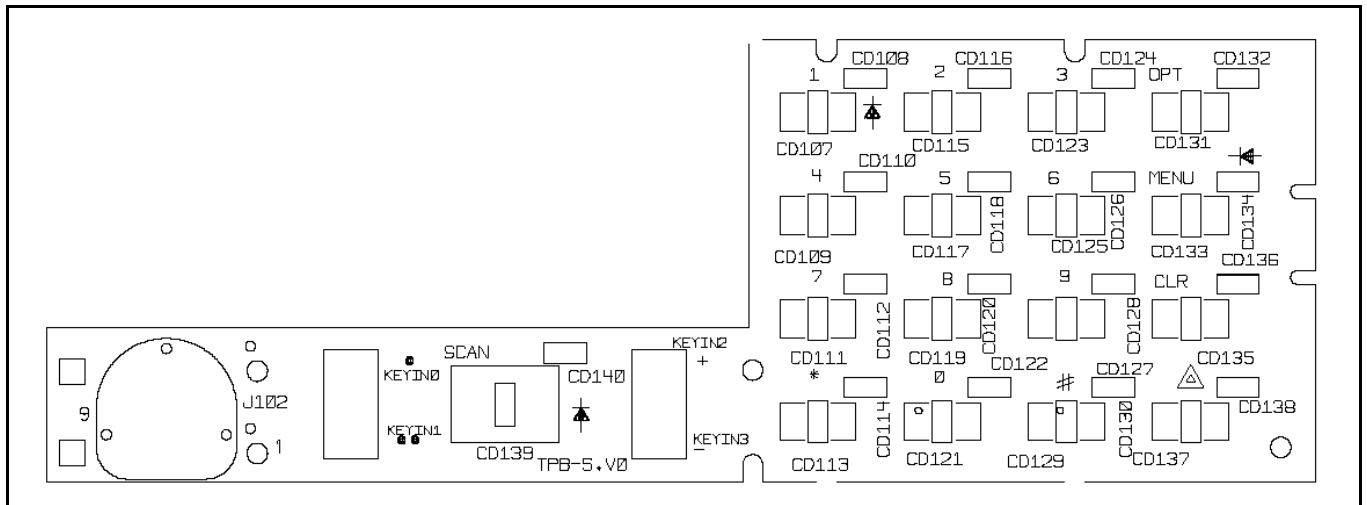

Figure 8-6: Switch Circuit CDF-368MC Solder Side

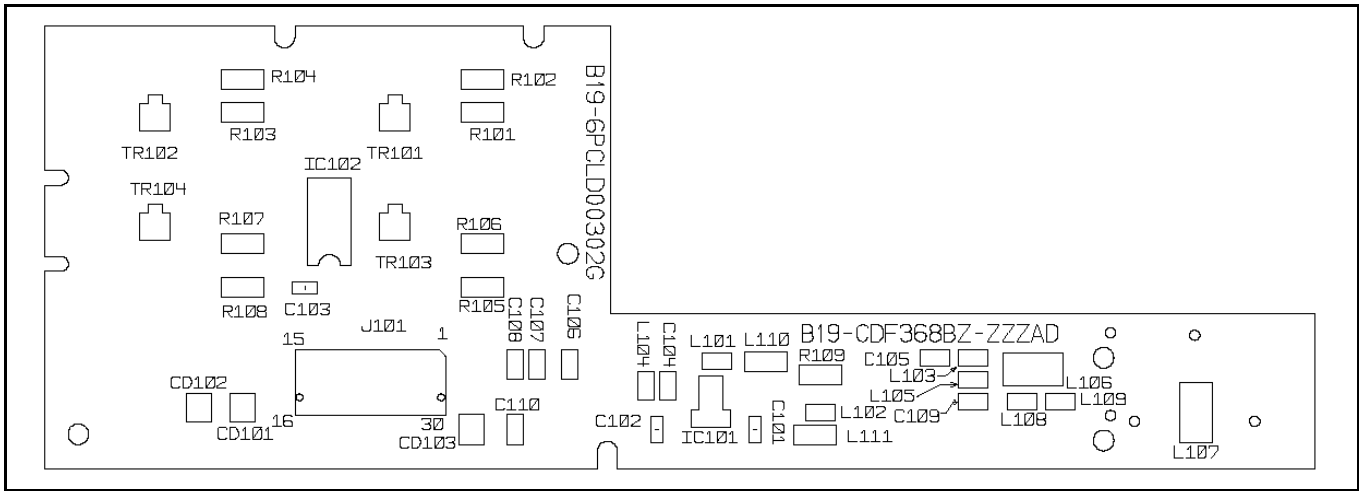

Figure 8-7: Switch Circuit CDF-368BC Component Side

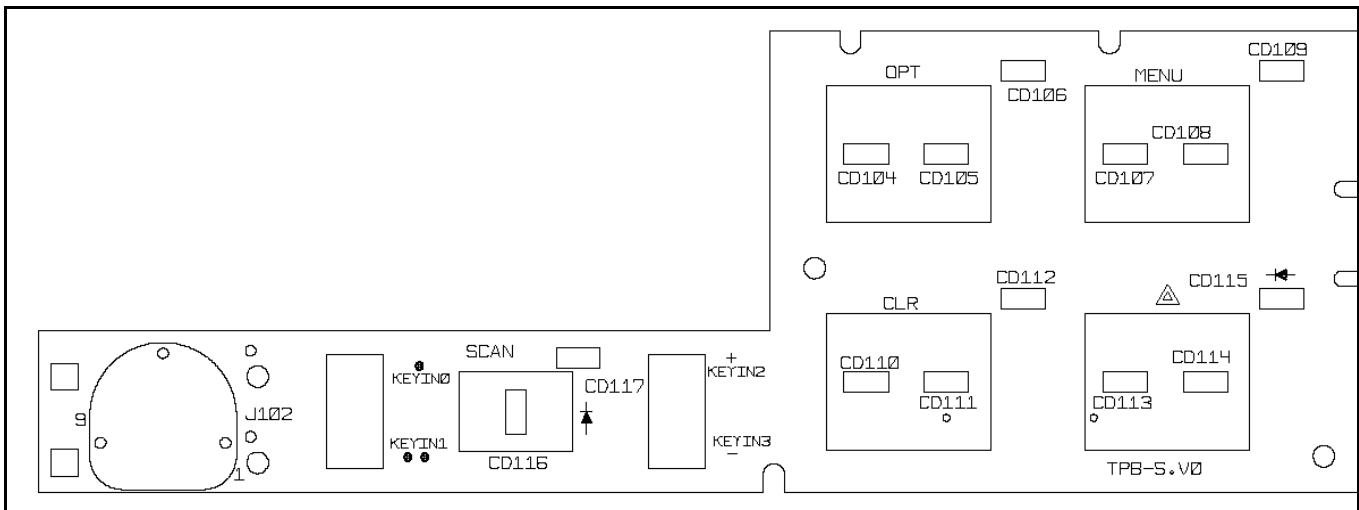

Figure 8-8: Switch Circuit CDF-368BC Solder Side

9 REPLACEABLE PARTS

Replaceable assemblies can be order through Tyco Electronics' Customer Resource Center. Component Items listed in the following pages and identified with M/A-COM part numbers are available through the Customer Resource Center. All other components are for reference only or are considered common parts. These items can be obtained from your local electronic parts distributor.

To order replacement parts, call or FAX our on-line ordering system:

U.S. & Canada 800-368-3277 International: 1-434-455-6403

FAX: 800-833-7592 FAX: 1-434-455-6676

e-mail: customerfocus@tycoelectronics.com e-mail: InternationalCustomerFocus@tycoelectronics.com

10 ASSEMBLY DIAGRAMS

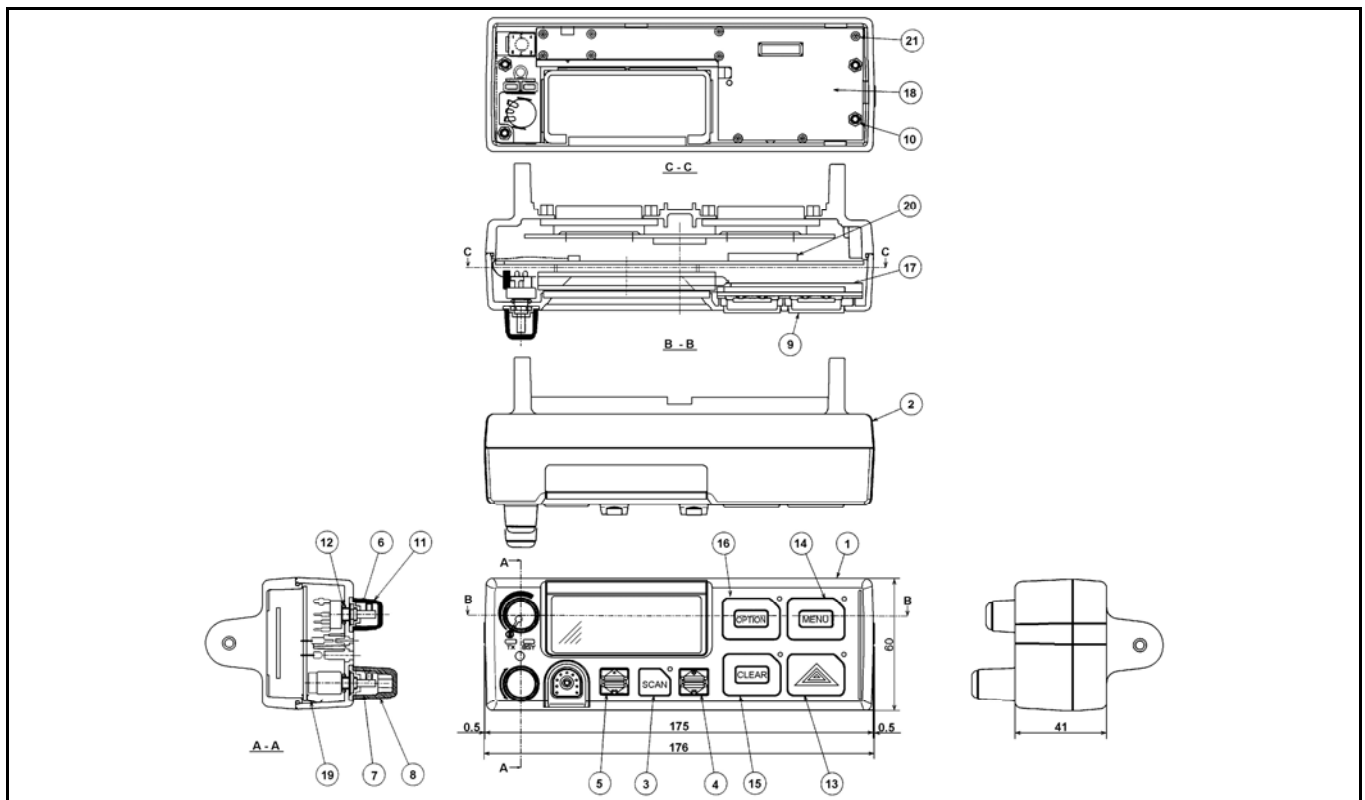

Figure 10-1: Remote Scan Model KRY 101 1632/12 (CMC-556 BRC, Sh. 2)

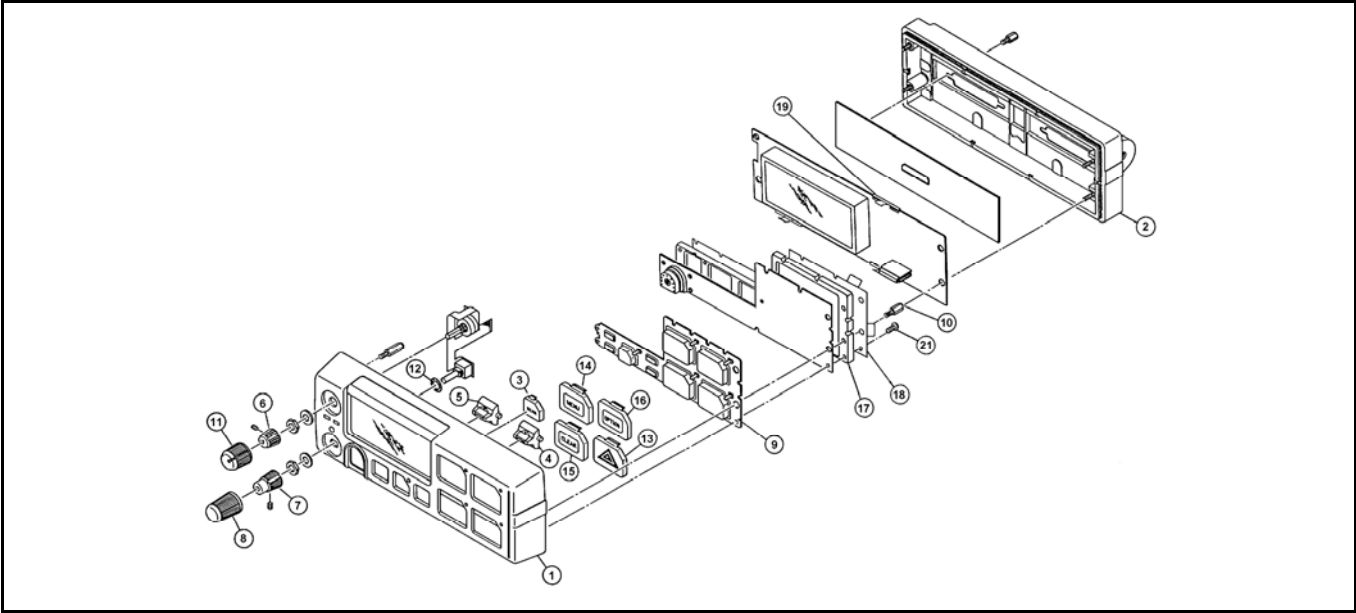

Figure 10-2: Remote Scan Model KRY 101 1632/12 CMC-556 BRC, Sh. 1)

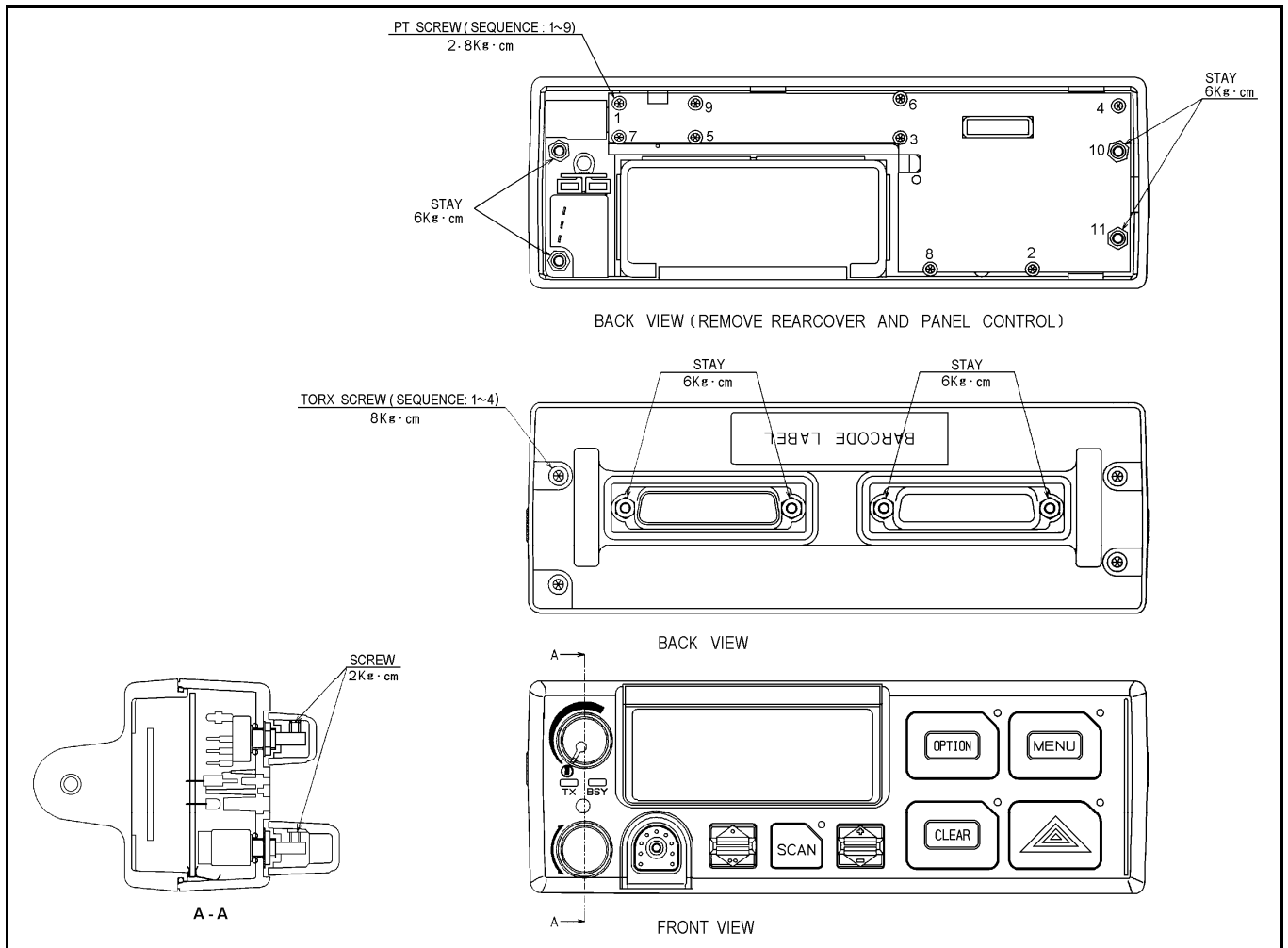

Figure 10-3: Remote Scan Model KRY 101 1632/12 CMC-556 BRC, Sh. 3)

Table 10-1: Remote Scan Model KRY 101 1632/12 (PL: CMC-556 BRC)

ITEM	PART NUMBER	DESCRIPTION
1	B19/MPBC33023	FRONT COVER (ASSEMBLY)
2	B19/MDNQZ5110A	REAR COVER (ASSEMBLY)
3	B19/MTV300540	KEYCAP (SCAN)
4	B19/MTV300002A	RAMPLEVER
5	B19/MTV300003A	RAMPLEVER
6	B19/MPHD30001A	KNOB (VOLUME)
7	B19/MPHD30002A	KNOB (SELECT)
8	B19/MTV300461	COVER KNOB (SELECT)
9	B19/MPPK30004A	RUBBER CONTACT
10	B19/MTL046412A	STAY
11	B19/MTV004931A	COVER KNOB (VOLUME)
12	B19/BRPK00561	GASKET
13	B19/MTV300606	KEYCAP (EMG)
14	B19/MTV300603	KEYCAP (MENU)
15	B19/MTV300604	KEYCAP (CLEAR)
16	B19/MTV300607	KEYCAP (OPTION)
17	B19/MTV301136B	REINFORCED BOARD
18	B19/MTB333792	SHIELD PLATE
19	B19/MPSR30227	CONTACT PLATE
20	B19/MTB333731	CASE SHIELD
21	B19/BRTG05174	PT SCREW
	19C852359P101	KEYCAP KIT
	19C852359P9	KEYCAP, (E)

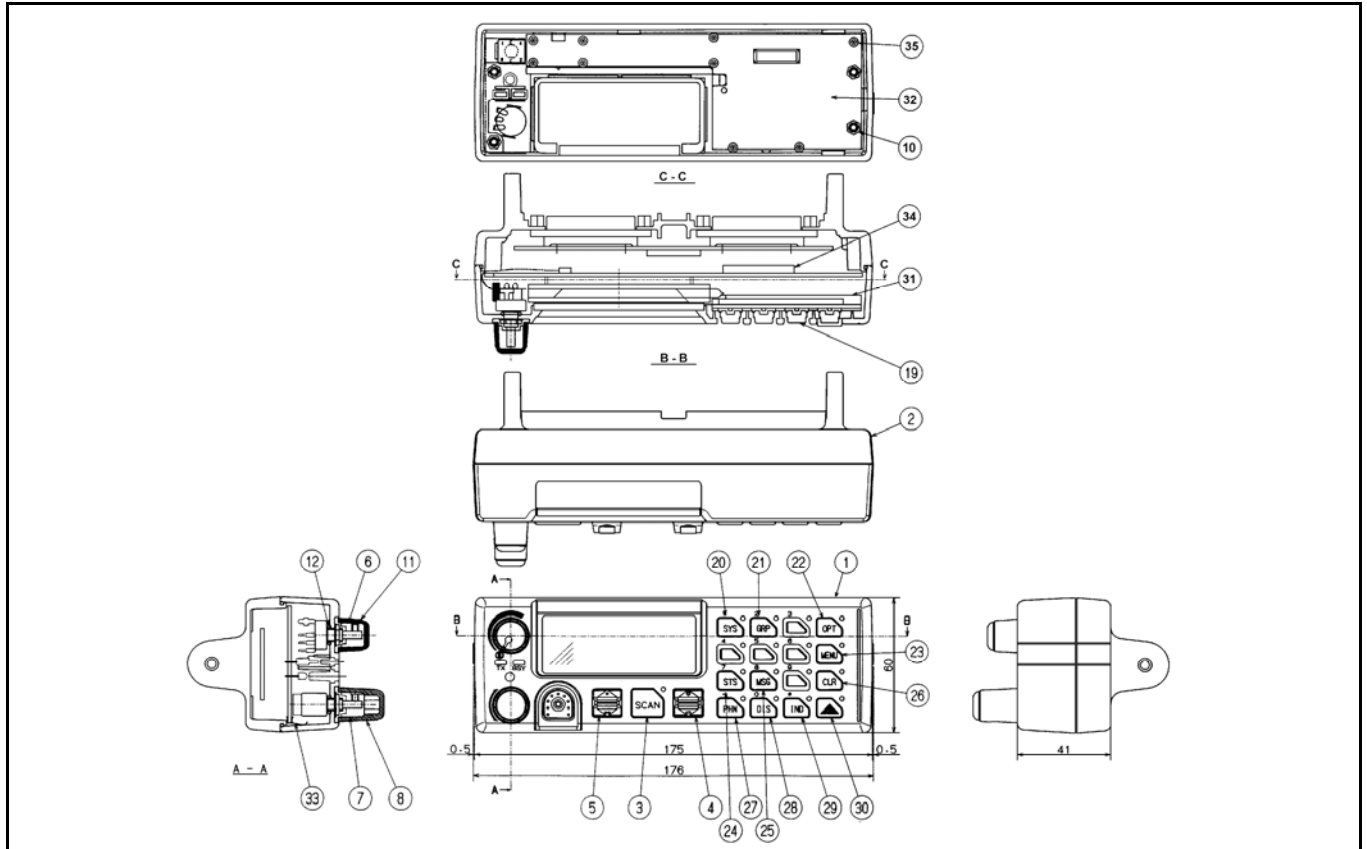

Figure 10-4: Remote System Model KRY 101 1632/14 (CMC-556 MRC, Sh. 2)

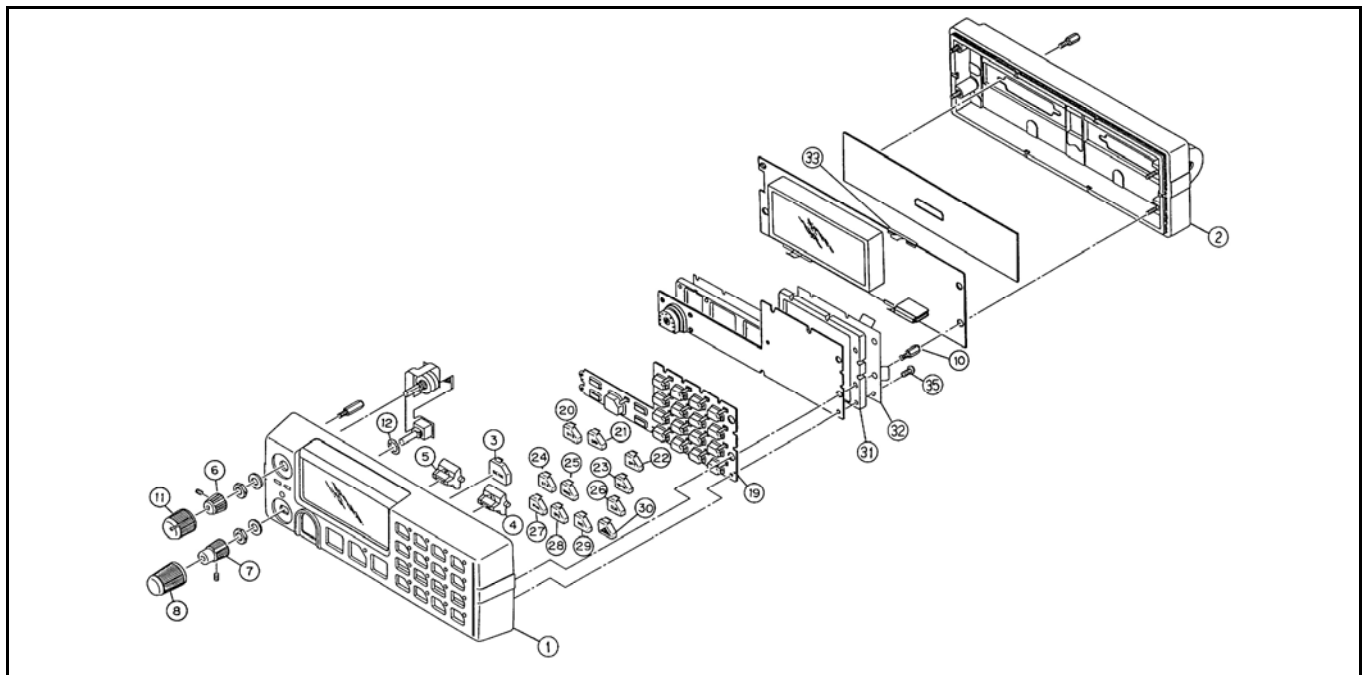

Figure 10-5: Remote System Model KRY 101 1632/14 (CMC-556 MRC, Sh. 1)

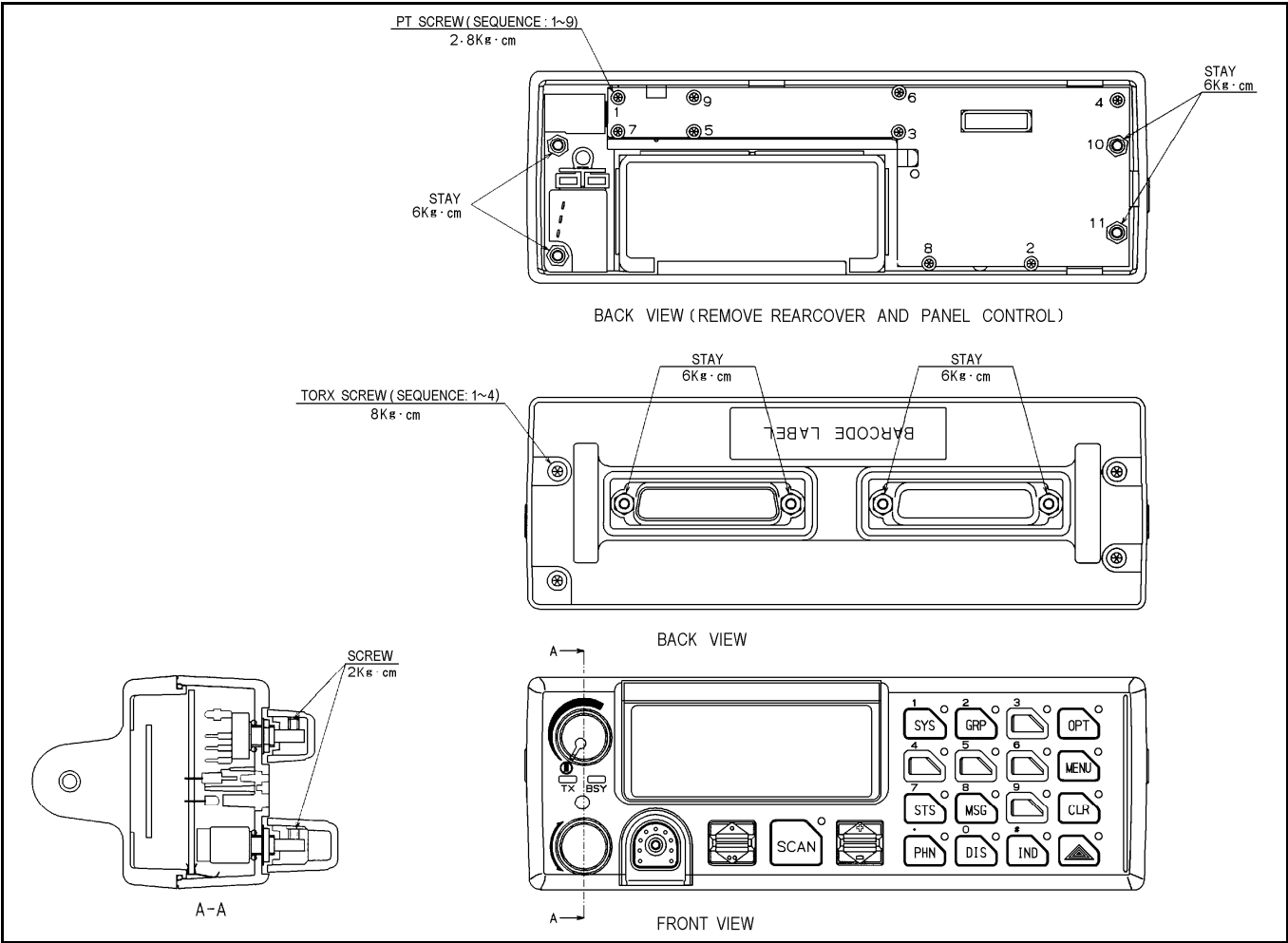

Figure 10-6: Remote System Model KRY 101 1632/14 (CMC-556 MRC, Sh. 3)

Table 10-2: Remote System Model KRY 101 1632/14 (PL: CMC-556 MRC)

ITEM	PART NUMBER	DESCRIPTION
1	B19/MPBC30348	FRONT PANEL (ASSEMBLY)
2	B19/MDNQZ5110A	REAR COVER (ASSEMBLY)
3	B19/MTV300540	KEYCAP (SCAN)
4	B19/MTV300002A	RAMPLEVER
5	B19/MTV300003A	RAMPLEVER
6	B19/MPHD30001A	KNOB (VOLUME)
7	B19/MPHD30002A	KNOB (SELECT)
8	B19/MTV300461	COVER KNOB (SELECT)
10	B19/MTL046412A	STAY
11	B19/MTV004931A	COVER KNOB (VOLUME)
12	B19/BRPK00561	GASKET
19	B19/MPPK01867A	RUBBER CONTACT
20	B19/MTV300542	KEYCAP (SYS)
21	B19/MTV300543	KEYCAP (GRP)
22	B19/MTV300544	KEYCAP (OPTION)
23	B19/MTV300545	KEYCAP (MENU)
24	B19/MTV300546	KEYCAP (STS)
25	B19/MTV300547	KEYCAP (MSG)
26	B19/MTV300548	KEYCAP (CLR)
27	B19/MTV300549	KEYCAP (PHN)
28	B19/MTV300550	KEYCAP (DIS)
29	B19/MTV300551	KEYCAP (IND)
30	B19/MTV300552	KEYCAP (EMG)
31	B19/MTV301136B	REINFORCED BOARD
32	B19/MTB333792	SHIELD PLATE
33	B19/MPSR30227	CONTACT PLATE
34	B19/MTB333731	CASE SHIELD
35	B19/BRTG05174	PT SCREW
	19C852358P101	STANDARD KEYCAP KIT
	19C852358P102	OPTIONAL KEYCAP KIT
	19C852359P9	KEYCAP (E)
	B19/MTV300600	KEYCAP (0)
	B19/MTV300599	KEYCAP (9)

ITEM	PART NUMBER	DESCRIPTION
	B19/MTV300598	KEYCAP (8)
	B19/MTV300597	KEYCAP (7)
	B19/MTV300595	KEYCAP (5)
	B19/MTV300594	KEYCAP (4)
	B19/MTV300593	KEYCAP (3)
	B19/MTV300592	KEYCAP (2)
	B19/MTV300591	KEYCAP (1)
	B19/MTV300584	KEYCAP (ST2)
	B19/MTV300583	KEYCAP (ST1)
	B19/MTV300582	KEYCAP (AUX2)
	B19/MTV300581	KEYCAP (AUX1)
	B19/MTV300578	KEYCAP (HOME)
	B19/MTV300576	KEYCAP (PA)
	B19/MTV300573	KEYCAP (PVT)
	B19/MTV300570	KEYCAP (SPK)
	B19/MTV300569	KEYCAP (SL8)
	B19/MTV300590	KEYCAP (ST8)
	B19/MTV300589	KEYCAP (ST7)
	B19/MTV300588	KEYCAP (ST6)
	B19/MTV300587	KEYCAP (ST5)
	B19/MTV300586	KEYCAP (ST4)
	B19/MTV300585	KEYCAP (ST3)
	B19/MTV300585	KEYCAP (ST3)
	B19/MTV300580	KEYCAP (#)
	B19/MTV300577	KEYCAP (MODE)
	B19/MTV300575	KEYCAP (GE)
	B19/MTV300574	KEYCAP (KEY)
	B19/MTV300572	KEYCAP (ST9)

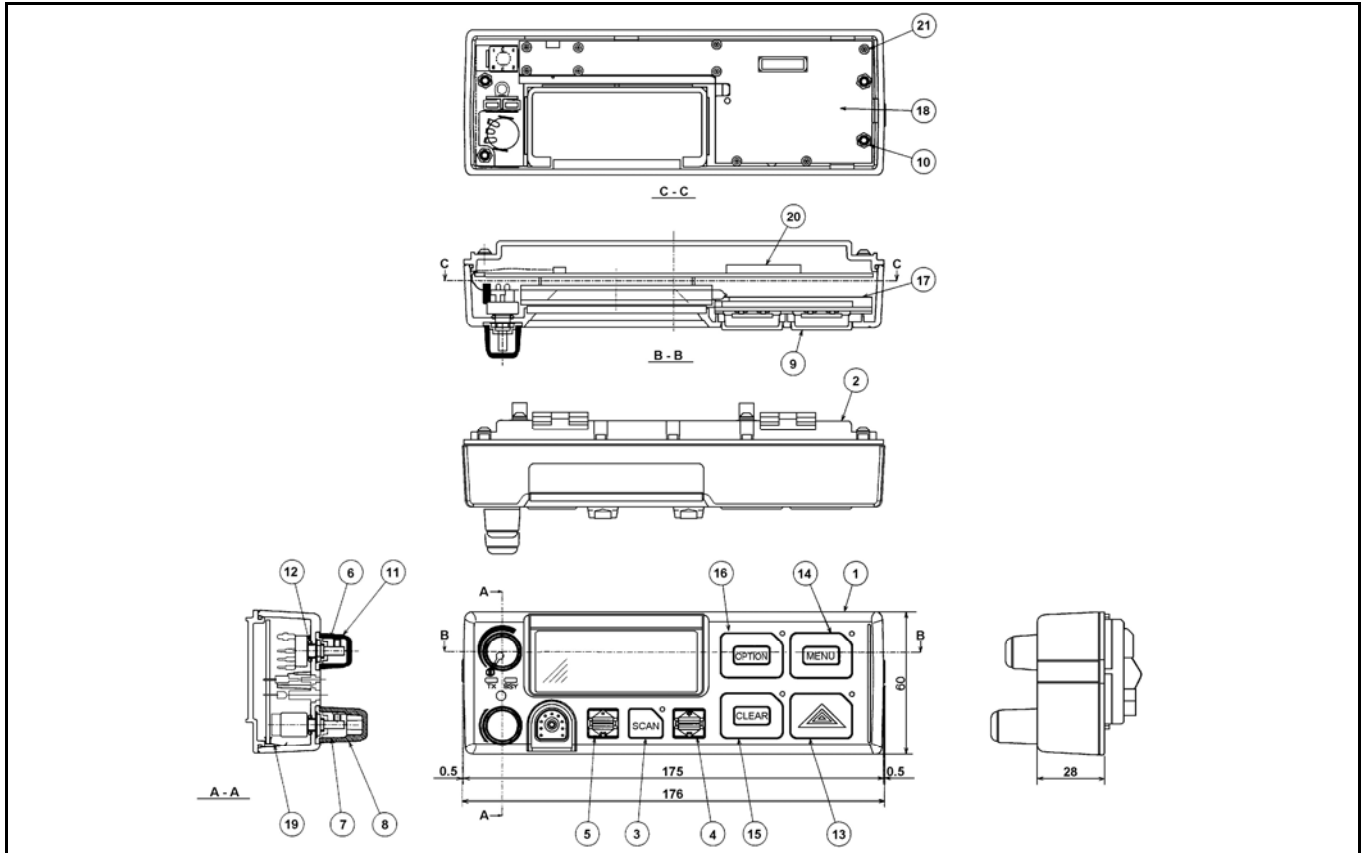

Figure 10-7: Local Scan Model KRY 101 1632/11 & KRY 101 1632/17 (CMC-556 BLC, Sh. 2)

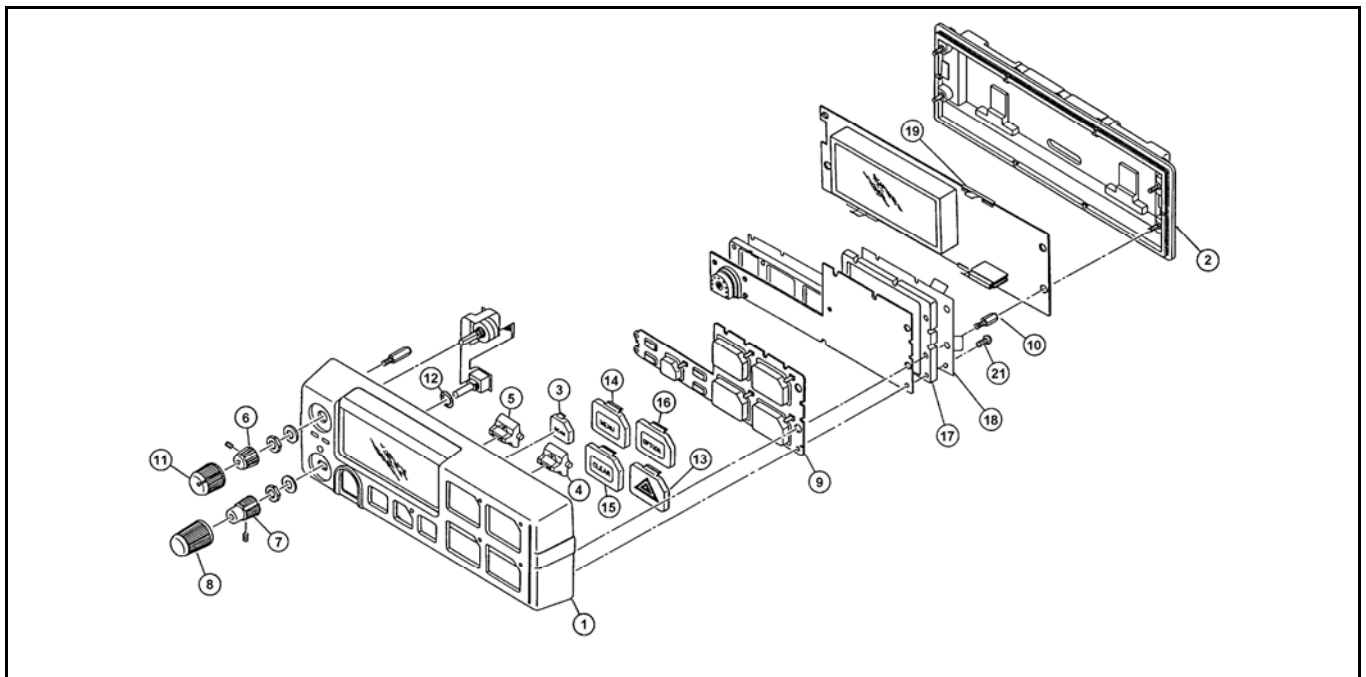

Figure 10-8: Local Scan Model KRY 101 1632/11 & KRY 101 1632/17 (CMC-556 BLC, Sh. 1)

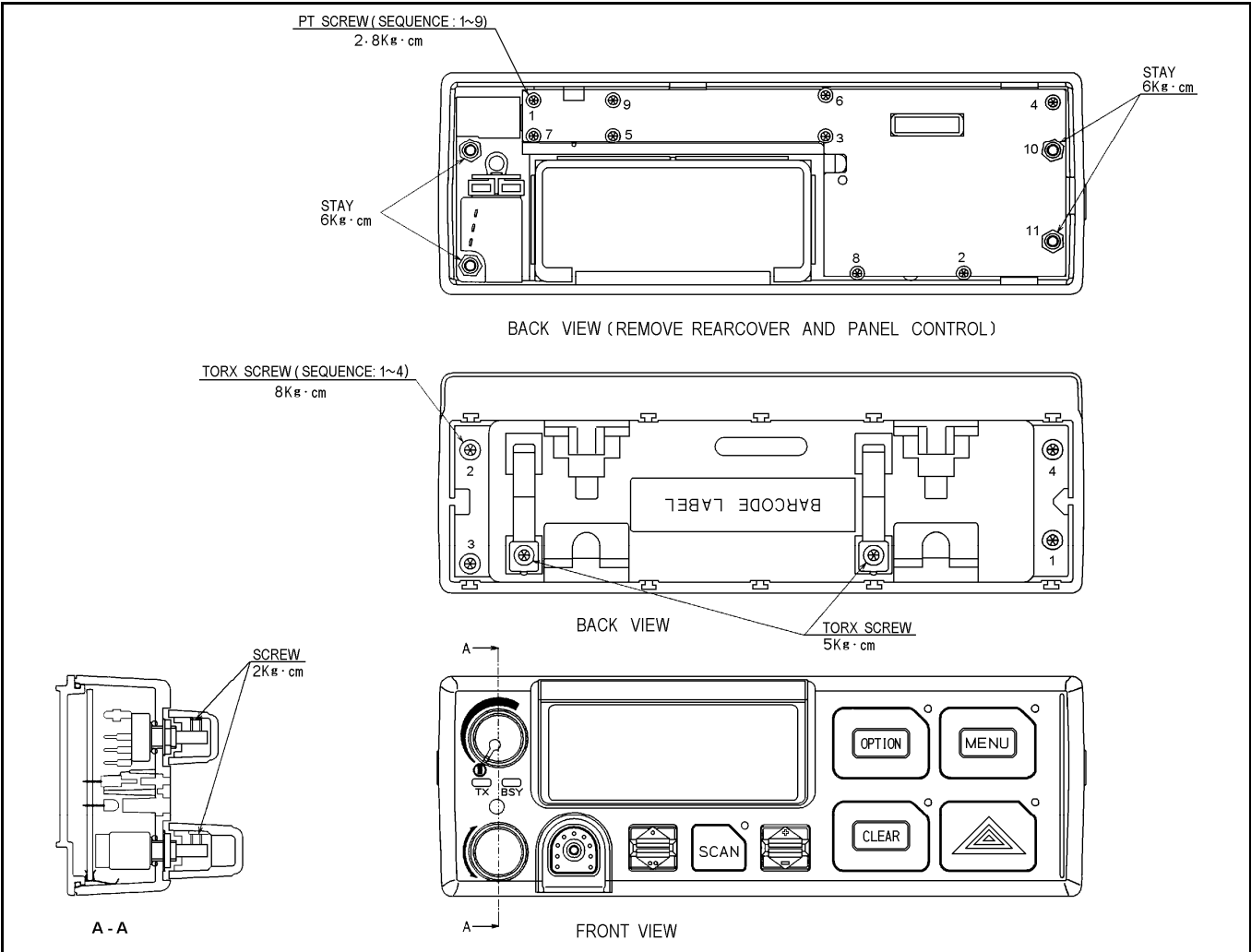

Figure 10-9: Local Scan Model KRY 101 1632/11 & KRY 101 1632/17 (CMC-556 BLC, Sh. 3)

Table 10-3: Local Scan Model KRY 101 1632/11 (PL: CMC-556 BLC)

ITEM	PART NUMBER	DESCRIPTION
1	B19/MPBC33023	FRONT COVER (ASSEMBLY)
2	B19/MPBC33024	REAR COVER (ASSEMBLY)
3	B19/MTV300540	KEYCAP (SCAN)
4	B19/MTV300002A	RAMPLEVER
5	B19/MTV300003A	RAMPLEVER
6	B19/MPHD30001A	KNOB (VOLUME)
7	B19/MPHD30002A	KNOB (SELECT)
8	B19/MTV300461	COVER KNOB (SELECT)
9	B19/MPPK30004A	RUBBER CONTACT
10	B19/MTL046412A	STAY
11	B19/MTV004931A	COVER KNOB (VOLUME)
12	B19/BRPK00561	GASKET
13	B19/MTV300606	KEYCAP (EMG)
14	B19/MTV300603	KEYCAP (MENU)
15	B19/MTV300604	KEYCAP (CLEAR)
16	B19/MTV300607	KEYCAP (OPTION)
17	B19/MTV301136B	REINFORCED BOARD
18	B19/MTB333792	SHIELD PLATE
19	B19/MPSR30227	CONTACT PLATE
20	B19/MTB333731	CASE SHIELD
21	B19/BRTG05174	PT SCREW
	19C852359P101	KEYCAP KIT
	19C852359P9	KEYCAP (E)

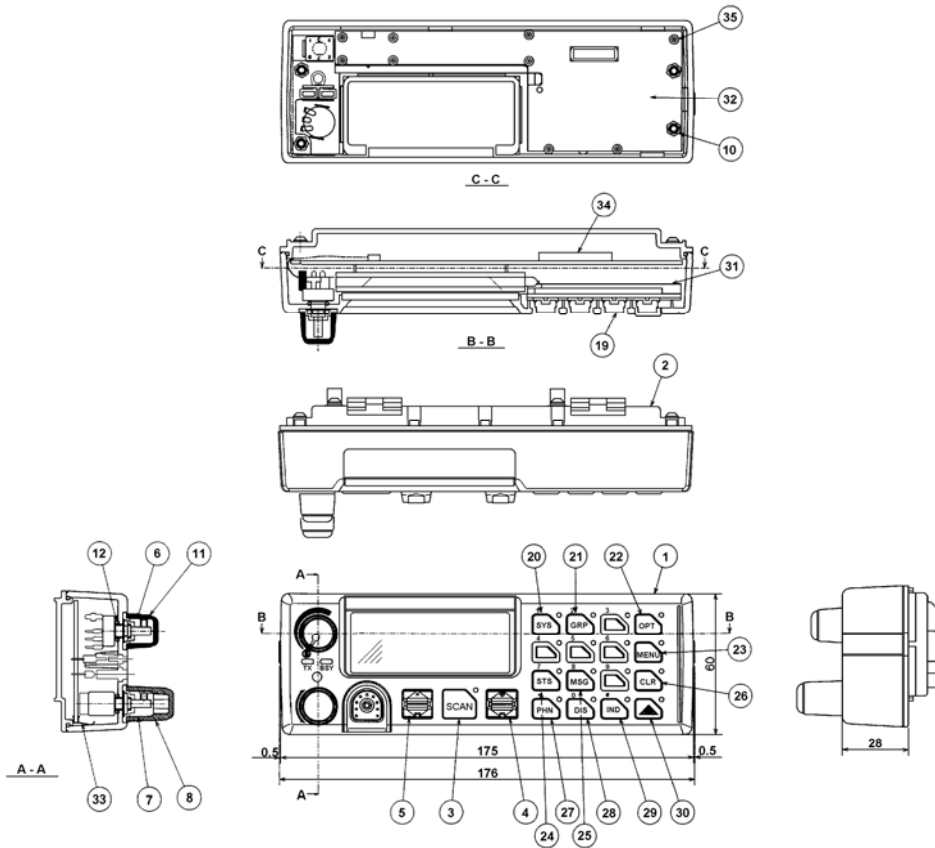

Figure 10-10: Local System Model KRY 101 1632/13 & KRY 101 1632/19 (CMC-556 MLC, Sh. 2)

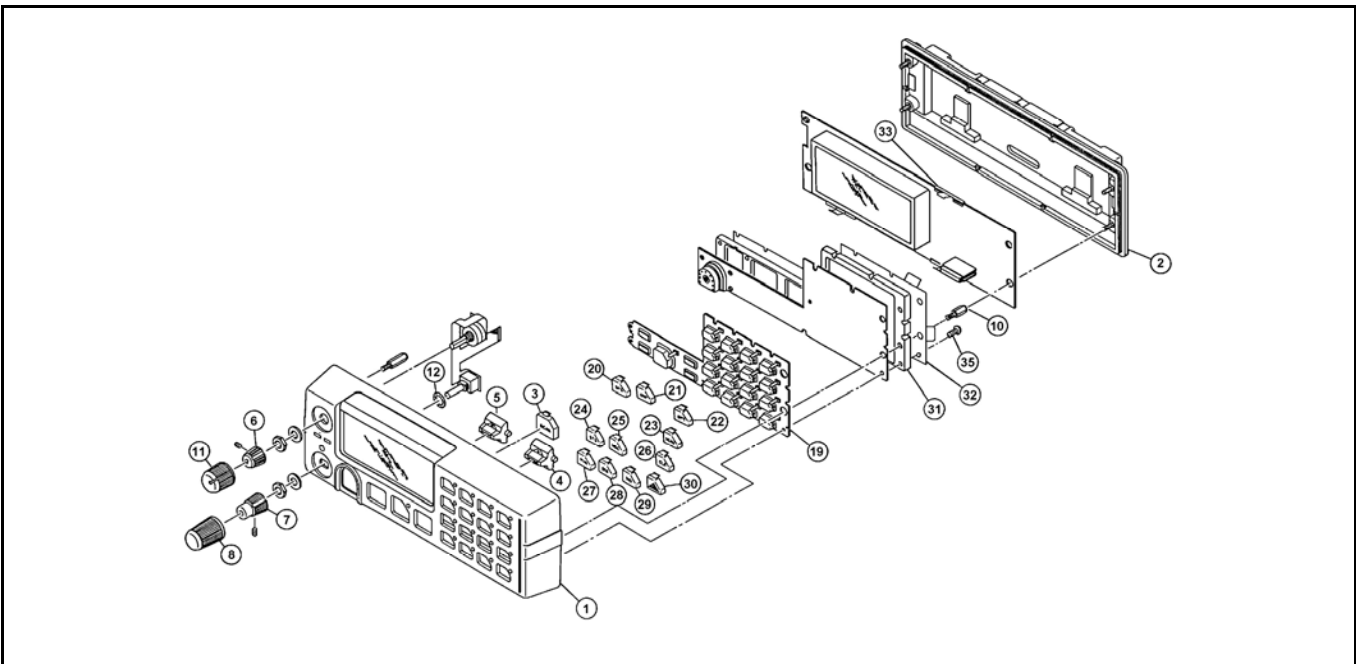

Figure 10-11: Local System Model KRY 101 1632/13 & KRY 101 1632/19 (CMC-556 MLC, Sh. 1)

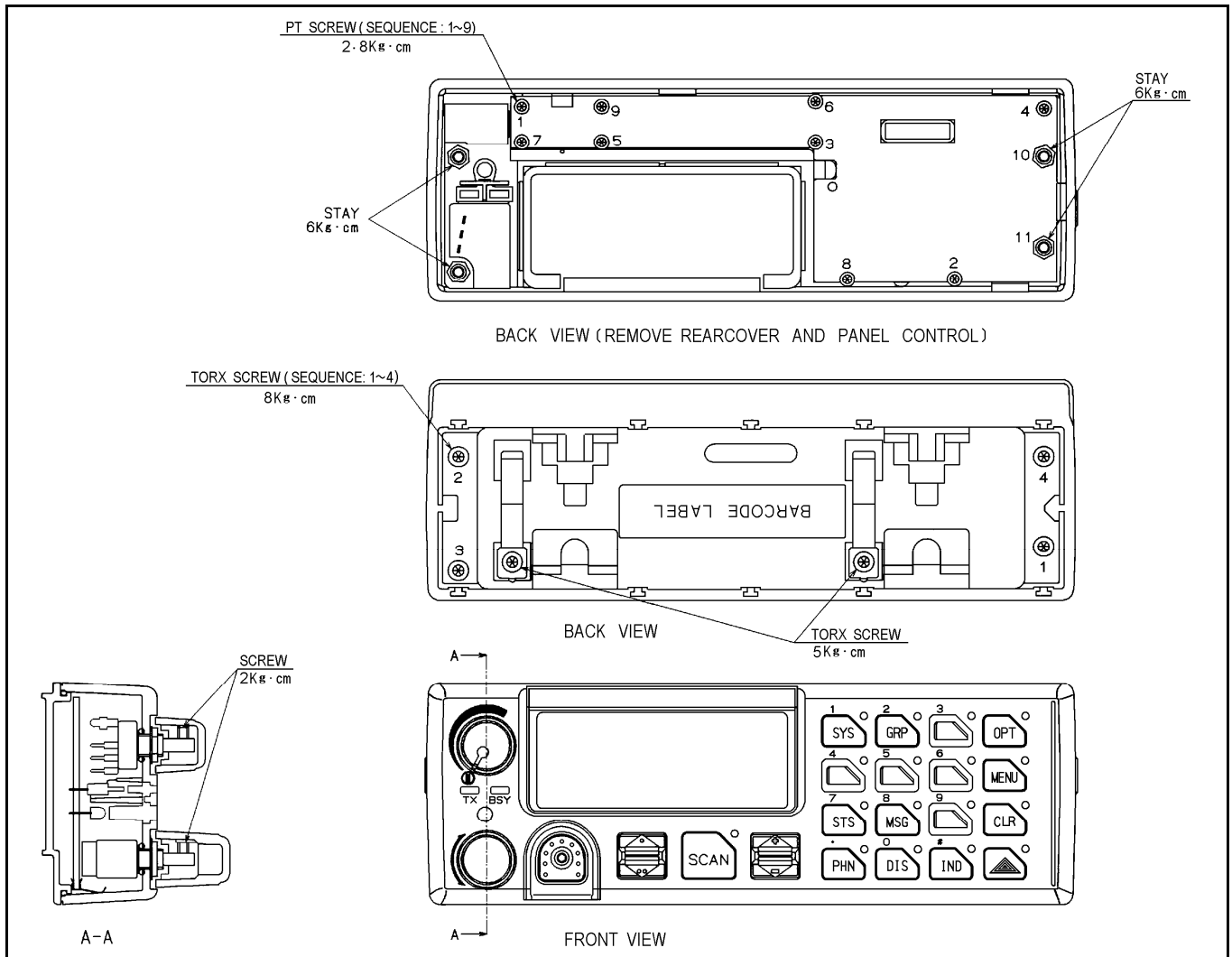

Figure 10-12: Local System Model KRY 101 1632/13 & KRY 101 1632/19 (CMC-556 MLC, Sh. 3)

Table 10-4: Local System Model KRY 101 1632/13 (PL: CMC-556 MLC)

ITEM	PART NUMBER	DESCRIPTION
1	B19/MPBC33022	FRONT COVER (ASSEMBLY)
2	B19/MPBC33024	REAR COVER (ASSEMBLY)
3	B19/MTV300540	KEYCAP (SCAN)
4	B19/MTV300002A	RAMPLEVER
5	B19/MTV300003A	RAMPLEVER
6	B19/MPHD30001A	KNOB (VOLUME)
7	B19/MPHD30002A	KNOB (SELECT)
8	B19/MTV300461	COVER KNOB (SELECT)
10	B19/MTL046412A	STAY
11	B19/MTV004931A	COVER KNOB (VOLUME)
12	B19/BRPK00561	GASKET
19	B19/MPPK01867A	RUBBER CONTACT
20	B19/MTV300542	KEYCAP (SYS)
21	B19/MTV300543	KEYCAP (GRP)
22	B19/MTV300544	KEYCAP (OPTION)
23	B19/MTV300545	KEYCAP (MENU)
24	B19/MTV300546	KEYCAP (STS)
25	B19/MTV300547	KEYCAP (MSG)
26	B19/MTV300548	KEYCAP (CLR)
27	B19/MTV300549	KEYCAP (PHN)
28	B19/MTV300550	KEYCAP (DIS)
29	B19/MTV300551	KEYCAP (IND)
30	B19/MTV300552	KEYCAP (EMG)
31	B19/MTV301136B	REINFORCED BOARD
32	B19/MTB333792	SHIELD PLATE
33	B19/MPSR30227	CONTACT PLATE
34	B19/MTB333731	CASE SHIELD
35	B19/BRTG05174	PT SCREW
	19C852358P101	STANDARD KEYCAP KIT
	19C852358P102	OPTIONAL KEYCAP KIT
	19C852359P9	KEYCAP (E)
	B19/MTV300600	KEYCAP (0)
	B19/MTV300599	KEYCAP (9)

ITEM	PART NUMBER	DESCRIPTION
	B19/MTV300598	KEYCAP (8)
	B19/MTV300597	KEYCAP (7)
	B19/MTV300595	KEYCAP (5)
	B19/MTV300594	KEYCAP (4)
	B19/MTV300593	KEYCAP (3)
	B19/MTV300592	KEYCAP (2)
	B19/MTV300591	KEYCAP (1)
	B19/MTV300584	KEYCAP (ST2)
	B19/MTV300583	KEYCAP (ST1)
	B19/MTV300582	KEYCAP (AUX2)
	B19/MTV300581	KEYCAP (AUX1)
	B19/MTV300578	KEYCAP (HOME)
	B19/MTV300576	KEYCAP (PA)
	B19/MTV300573	KEYCAP (PVT)
	B19/MTV300570	KEYCAP (SPK)
	B19/MTV300569	KEYCAP (SL8)
	B19/MTV300590	KEYCAP (ST8)
	B19/MTV300589	KEYCAP (ST7)
	B19/MTV300588	KEYCAP (ST6)
	B19/MTV300587	KEYCAP (ST5)
	B19/MTV300586	KEYCAP (ST4)
	B19/MTV300585	KEYCAP (ST3)
	B19/MTV300585	KEYCAP (ST3)
	B19/MTV300580	KEYCAP (#)
	B19/MTV300577	KEYCAP (MODE)
	B19/MTV300575	KEYCAP (GE)
	B19/MTV300574	KEYCAP (KEY)
	B19/MTV300572	KEYCAP (ST9)

11 PARTS LIST

11.1 CONTROL UNIT

CONTROL UNIT
KRY 101 1632/11, CMD-556BLC (Scan Model Local Type) Rev. 4B

SYMBOL	PART NO.	DESCRIPTION
A1	B19/CDF-368BC	SWITCH CIRCUIT CDF-368BC.
A2	B19/CMC-638C	PANEL CONTROL CMC-638C.
PC1	B19/6PCLD00307	FLEX CIRCUIT.
PC2	B19/6PCLD00321	FLEX CIRCUIT
S1	B19/5SZJC00021	ROTARY SWITCH KER16-35.
S2	B19/5RVAC00106	POTENTIOMETER, VOLUME CONTROL

CONTROL UNIT
KRY 101 1632/12, CMD-556BRC (Scan Model Remote Type) Rev. 4B

SYMBOL	PART NO.	DESCRIPTION
A1	B19/CDF-368BC	SWITCH CIRCUIT CDF-368BC.
A2	B19/CMC-638C	PANEL CONTROL CMC-638C.
A3	B19/NQZ-4882C	REMOTE INTERFACE ADAPTOR RIA NQZ-4882C.
PC1	B19/6PCLD00307	FLEX CIRCUIT
PC2	B19/6PCLD00321	FLEX CIRCUIT
S1	B19/5SZJC00021	ROTARY SWITCH KER16-35.
S2	B19/5RVAC00106	POTENTIOMETER, VOLUME CONTROL

CONTROL UNIT
KRY 101 1632/13, CMD-556MLC (Scan Model Local Type) Rev. 4B

SYMBOL	PART NO.	DESCRIPTION
A1	B19/CDF-368MC	SWITCH CIRCUIT CDF-368MC.
A2	B19/CMC-638C	PANEL CONTROL CMC-638C.
PC1	B19/6PCLD00307	FLEX CIRCUIT.
PC2	B19/6PCLD00321	FLEX CIRCUIT.
S1	B19/5SZJC00021	ROTARY SWITCH KER16-35.
S2	B19/5RVAC00106	POTENTIOMETER, VOLUME CONTROL

CONTROL UNIT
KRY 101 1632/14, CMD-556MRC (Scan Model Remote Type) Rev. 4B

SYMBOL	PART NO.	DESCRIPTION
A1	B19/CDF-368MC	SWITCH CIRCUIT CDF-368MC.
A2	B19/CMC-638C	PANEL CONTROL CMC-638C.
A3	B19/NQZ-4882C	REMOTE INTERFACE ADAPTOR RIA NQZ-4882C.
PC1	B19/6PCLD00307	FLEX CIRCUIT.
PC2	B19/6PCLD00321	FLEX CIRCUIT.
S1	B19/5SZJC00021	ROTARY SWITCH KER16-35.
S2	B19/5RVAC00106	POTENTIOMETER, VOLUME CONTROL

11.2 PANEL CONTROL

PANEL CONTROL
CMC-638C (Used in P1, P2, P3, P4) Rev. 1B

SYMBOL	PART NO.	DESCRIPTION
		----- CAPACITORS -----
C201 thru C226	B19/5CAAA05886	Ceramic: 100 pF ±5% 50 VDCW temp coef ±60 PPM.
C227 and C228	B19/5CAAD02363	Ceramic: 27 pF ±5% 50 VDCW temp coef ±30 PPM.
C229 and C230	B19/5CBAB03556	Ceramic: 0.1 uF ±10%, 25 VDCW temp coef ±10%
C231 and C232	B19/5CEAA04013	Polypropyiene: 10 uF ±20% 16 VDCW.
C233	B19/5CBAB03656	Ceramic:1000 pF ±10% 50 VDCW temp coef ±15%.
C234	B19/5CAAA05886	Ceramic: 100 pF ±5% 50 VDCW temp coef ±60 PPM.
C235	B19/5CBAB03556	Ceramic: 0.1 uF ±10%, 25 VDCW temp coef ±10%
C236	B19/5CBAB03626	Ceramic: 0.047 uF ±10%, 25 VDCW temp coef ±10%
C237	B19/5CEAA04013	Polypropyiene: 10 uF ±20% 16 VDCW.
C238	B19/5CBAB03556	Ceramic: 0.1 uF ±10%, 25 VDCW temp coef ±10%
C239	B19/5CEAA04013	Polypropyiene: 10 uF±20% 16 VDCW.
C240 and C241	B19/5CBAB03556	Ceramic: 0.1 uF ±10%, 25 VDCW temp coef ±10%
C242	B19/5CEAA04013	Polypropyiene: 10 uF±20% 16 VDCW.
C243 thru C247	B19/5CAAA05886	Ceramic: 100 pF ±5% 50 VDCW temp coef ±60 PPM.
C248	B19/5CBAB03625	Ceramic: 0.01 uF ±10% 50 VDCW, temp coef ±10%.
C249	B19/5CAAD03707	Ceramic:100 pF ±5% 50 VDCW temp coef ±30 PPM.
C250	B19/5CEAA02858	Electrolytic: 1 uF ±20% 16V.
C251	B19/5CEAA04475	Polypropyiene: 10 uF±20% 50 VDCW.
C252	B19/5CEAA04091	Tantalum: 47 uF ±20% 16 VDCW.
C253	B19/5CEAA03372	Tantalum: 3.3 uF ±20% 16 VDCW.
C254	B19/5CBAB03656	Ceramic:1000 pF ±10% 50 VDCW temp coef ±15%.

SYMBOL	PART NO.	DESCRIPTION
C255	B19/5CBAB03625	Ceramic: 0.01 uF ±10% 50 VDCW, temp coef ±10%.
C256	B19/5CBAB03556	Ceramic: 0.1 uF ±10%, 25 VDCW temp coef ±10%
C257	B19/5CSAA00347	Tantalum: 22 uF ±20% 16 VDCW.
----- DIODES -----		
CD201	B19/5TZAD00560	Optoelectronic: orange sim to TOSHIBA TLO205.
CD202	B19/5TZAD00296	Optoelectronic: red sim to TOSHIBA TLR205.
CD203	B19/5TXAD00290	Silicon fast recovery (2 diodes in cathode common); sim to TOSHIBA ISS184.
CD204 thru CD219	B19/5TXAD00320	Silicon fast recovery (2 diodes in series); sim to TOSHIBA ISS226.
CD220	B19/5TXCW00082	Zener: 5.1 V; sim to ROHM RLZ5.1B.
CD221	B19/5TXCW00287	Silicon Epitaxial Planar Diode: sim to ROHM RLS73 TE-1.
CD222	B19/5TXCW00084	Silicon Epitaxial Planar Diode: sim to ROHM RLS245.
CD223	B19/5TXCW00082	Zener: 5.1 V; sim to ROHM RLZ5.1B.
----- FUSE -----		
F200 and F201	B19/5ZFAP00037	Fuse: 3A; sim to LITTEL FUSE 0433 003NR
-----INTEGRATED CIRCUITS -----		
IC201	B19/5DAAN00202	Linear, Dual OP AMP; sim to NEW JRC NJM3404M.
IC202	B19/5DDEH00128	Digital: EEPROM; sim to ATMEL AT24C04N-10SI-2.7-TEL.
IC203	B19/7DLLD0004	Digital: Microcomputer; sim to HITACHI HD6433308RC28F.
IC204	B19/5DDAL03419	RS-485 Transceiver: sim to TEXAS INSTRUMENTS SN75176BPSR.
IC205	B19/5DDAE01621	Digital: Bilateral; sim to TOSHIBA TC4S66F-TE85L.
IC206	B19/5DVBM00001	Linear: System Reset IC; sim to MITSUMI PST3645UR.
IC207	B19/5DVBG00061	Linear: Positive Voltage Regulator; sim to MOTOROLA MC7805CT.
IC208	B19/5DVBG00062	Linear: Positive Voltage Regulator; sim to MOTOROLA MC7809CT.
IC209	B19/5DAAB00254	Digital: VFD Controller: sim to MITSUBISI M66004FP.
IC210 and IC211	B19/5DZAD00343	Linear: Photocoupler; sim to TOSHIBA TLP121GB-TLP.
----- CONNECTORS -----		
J201	B19/5JBAX00023	Connector: 12 pins.
J202	B19/5JBAX00011	Connector: 30 pins.
J203	B19/5JBAX00020	Connector: 18 pins.
-----RELAY -----		
K200	B19/5KGAG00184	Photo Mos Relay; sim to MATSUSHITA ELECTRIC WORKS AQY210SX.
-----COILS -----		
L201 and L202	B19/5LCAT00102	Choke Coil: 10 uH .

SYMBOL	PART NO.	DESCRIPTION
		-----RESISTORS -----
R201 and R202	B19/5REAG01827	Metal film: 470 ohms $\pm 5\%$, 150 VDCW 1/10W.
R203	B19/5REAG01854	Metal film: 100 ohms $\pm 5\%$, 150 VDCW 1/2W.
R204 and R205	B19/5REAG01814	Metal film: 1K ohms $\pm 5\%$, 150 VDCW 1/4W.
R206	B19/5REAG02597	Metal film: 270K ohms $\pm 5\%$, 150 VDCW 1/4W.
R207 thru R219	B19/5REAG01854	Metal film: 100 ohms $\pm 5\%$, 150 VDCW 1/2W.
R220	B19/5REAG03419	Metal film: 47 ohms $\pm 5\%$, 200 VDCW 1/2W.
R221	B19/5REAG03255	Metal film: 100 ohms $\pm 5\%$, 200 VDCW 1/4W.
R222	B19/5REAG01823	Metal film: 4.7K ohms $\pm 5\%$, 150 VDCW 1/10W.
R223 thru R242	B19/5REAG02017	Metal film: 10K ohms $\pm 5\%$, 150 VDCW 1/10W.
R243	B19/5REAG01823	Metal film: 4.7k ohms $\pm 5\%$, 150 VDCW 1/10W.
R244	B19/5REAG01854	Metal film: 100 ohms $\pm 5\%$, 150 VDCW 1/10W.
R245 and R246	B19/5REAG01823	Metal film: 4.7k ohms $\pm 5\%$, 150 VDCW 1/10W.
R247	B19/5ZZAB10000	
R248	B19/5REAG02017	Metal film: 10K ohms $\pm 5\%$, 150 VDCW 1/10W.
R250 thru R253	B19/5REAG01854	Metal film: 100 ohms $\pm 5\%$, 150 VDCW 1/10W.
R254	B19/5REAG02331	Metal film: 47K ohms $\pm 5\%$, 150 VDCW 1/10W.
R255	B19/5REAG02022	Metal film: 15K ohms $\pm 5\%$, 150 VDCW 1/10W.
R256	B19/5REAG02011	Metal film: 2.2K ohms $\pm 5\%$ 150 VDCW.1/10W.
R257	B19/5REAG01854	Metal film: 100 ohms $\pm 5\%$, 150 VDCW 1/10W.
R258	B19/5REAG01675	Metal film: 33K ohms $\pm 5\%$, 150 VDCW 1/10W.
R259	B19/5REAG04039	Metal film: 68 ohms $\pm 5\%$, 200 VDCW 1/4W.
R260	B19/5REAG02018	Metal film: 1.8k ohms $\pm 5\%$, 150 VDCW 1/10W.
R261	B19/5REAG01816	Metal film: 22K ohms $\pm 5\%$, 150 VDCW 1/10W.
R263	B19/5REAG01816	Metal film: 22K ohms $\pm 5\%$, 150 VDCW 1/10W.
R264	B19/5REAG02006	Metal film: 2.7K ohms $\pm 5\%$, 150 VDCW 1/10W.
R265	B19/5REAG01816	Metal film: 22K ohms $\pm 5\%$,150 VDCW 1/10W.
R266	B19/5REAG02006	Metal film: 2.7K ohms $\pm 5\%$, 150 VDCW 1/10W.
R267	B19/5REAG01816	Metal film: 22K ohms $\pm 5\%$,150 VDCW 1/10W.
R268	B19/5REAG02006	Metal film: 2.7K ohms $\pm 5\%$, 150 VDCW 1/10W.
R270	B19/5REAG01817	Metal film: 680 ohms $\pm 5\%$, 150 VDCW 1/10W.
		----- SWITCH -----
S201	B19/5SAFB00002	Slide switch: sim to SMK JSC1210-0111.
		-----TRANSFORMER -----
T201	B19/5LRAK00004	Transformer: sim to SUMIDA IS625.
		----- TRANSISTOR -----
TR201	B19/5TCCF00005	Phototransistor: sim to STANLEY ELECTRIC PS3072.
TR202 and TR203	B19/5TDAB00054	Silicon NPN: sim to NEC 2SD596 (DV3.)
TR204 and TR205	B19/5TZCU00123	Silicon, NPN: sim to ROHM DTC114EKAT146.

SYMBOL	PART NO.	DESCRIPTION
TR206 and TR207	B19/5TBAB00055	Silicon, PNP: sim to NEC 2SB624 (BV3).
TR208	B19/5TCAF00585	Silicon, NPN: sim to TOSHIBA 2SC2712.
TR209	B19/5TCAF00658	Silicon, NPN: sim to TOSHIBA 2SC2873.
TR210 and TR211	B19/5TKAD00169	N-Channel Field Effect: sim to NEC 2SK1582.
TR212	B19/5TCAB01554	Silicon, NPN: sim to NEC 2SC3736.
TR213	B19/5TKAD00169	N-Channel Field Effect: sim to NEC 2SK1582.
VFD201	B19/7WSLD0004	VFD: sim to ISE ELECTRONICS DH0827AB. ----- VACUUM FLUORESCENT DISPLAY -----
X201	B19/5XHAL00002	Crystal: F=7.3728 MHz. ----- CRYSTAL -----

11.3 SWITCH CIRCUIT

SWITCH CIRCUIT
CDF-368BC (Used in /11, /12) Rev. 2A

SYMBOL	PART NO.	DESCRIPTION
C101 thru C103	B19/5CBAB03556	-----CAPACITORS ----- Ceramic: 0.1 uF ±10% 25 VDCW, temp coef 0±10PPM.
C104 thru C110	B19/5CAAD02069	Ceramic: 1000 pF +80%,-20% 50 VDCW, temp coef +22%,-82%.
CD101 thru CD103	B19/5TXAD00637	----- DIODES ----- Silicon: fast recovery (2 diodes in cathode common); sim to TOSHIBA 1SS300.
CD104 and CD105	B19/5TZET00009	Optoelectronic: orange, sim to CITIZEN CL-150D-CD.
CD106	B19/5TZET00022	Optoelectronic: red, sim to CITIZEN CL-150UR-CD.
CD107 and CD108	B19/5TZET00009	Optoelectronic: orange, sim to CITIZEN CL-150D-CD.
CD109	B19/5TZET00022	Optoelectronic: red, sim to CITIZEN CL-150UR-CD.
CD110 and CD111	B19/5TZET00009	Optoelectronic: orange, sim to CITIZEN CL-150D-CD.
CD112	B19/5TZET00022	Optoelectronic: red, sim to CITIZEN CL-150UR-CD.
CD113 and CD114	B19/5TZET00022	Optoelectronic: red, sim to CITIZEN CL-150UR-CD.
CD115	B19/5TZET00022	Optoelectronic: red, sim to CITIZEN CL-150UR-CD.
CD116	B19/5TZET00009	Optoelectronic: orange, sim to CITIZEN CL-150D-CD.
CD117	B19/5TZET00022	Optoelectronic: red, sim to CITIZEN CL-150UR-CD.
IC101	B19/5DAAD00664	----- INTEGRATED CIRCUITS ----- Linear: Positive Voltage Regulator; sim to TOSHIBA TA78L05F.
IC102	B19/5DZAB00118	Digital, 8 BIT Shift Register; sim to TEXAS INSTRUMENTS SN74HC595ANSR.

SYMBOL	PART NO.	DESCRIPTION
		----- CONNECTORS -----
J101	B19/5JBAX00007	Connector: 30 pins.
J102	B19/5JWHZ00048	Connector: 9 pins.
		----- INDUCTORS -----
L101 thru L105	B19/5LCAA01306	Line Filter: Z=1800 ohms
L106 and L107	B19/5LCAA01365	Line Filter: Z=1600 ohms
L108 and L109	B19/5LCAA01306	Line Filter: Z=1800 ohms
L110 and L111	B19/5LCAA00787	Inductor: 10 uH ±10%.
		----- RESISTORS -----
R101	B19/5REAG01733	Metal film: 390 ohms ±5%, 100 VDCW 1/8W.
R102	B19/5REAG01744	Metal film: 3.3K ohms ±5%, 100 VDCW 1/8W.
R103	B19/5REAG01734	Metal film: 470 ohms ±5%, 100 VDCW 1/8W.
R104	B19/5REAG01744	Metal film: 3.3K ohms ±5%, 100 VDCW 1/8W.
R105	B19/5REAG01734	Metal film: 470 ohms ±5%, 100 VDCW 1/8W.
R106	B19/5REAG01744	Metal film: 3.3K ohms ±5%, 100 VDCW 1/8W.
R107	B19/5REAG01734	Metal film: 470 ohms ±5%, 100 VDCW 1/8W.
R108 and R109	B19/5REAG01744	Metal film: 3.3K ohms ±5%, 100 VDCW 1/8W.
		----- TRANSISTOR -----
TR101 thru TR104	B19/5TZCU00123	Silicon NPN: sim to ROHM DTC114EKAT146.

SWITCH CIRCUIT

CDF-368MC (Used in /13, /14) Rev. 2A

SYMBOL	PART NO.	DESCRIPTION
C101 thru C104	B19/5CBAB03556	Ceramic: 0.1 uF ±10% 25 VDCW, temp coef 0±10PPM.
C105 thru C111	B19/5CAAD02069	Ceramic: 1000 pF +80%,-20% 50 VDCW, temp coef +22%,-82%.
		----- DIODES -----
CD101 thru CD106	B19/5TXAD00637	Silicon: fast recovery (2 diodes in cathode common); sim to TOSHIBA 1SS300.
CD107	B19/5TZET00009	Optoelectronic: orange, sim to CITIZEN CL-150D-CD.
CD108	B19/5TZET00022	Optoelectronic: red, sim to CITIZEN CL-150UR-CD.
CD109	B19/5TZET00009	Optoelectronic: orange, sim to CITIZEN CL-150D-CD.
CD110	B19/5TZET00022	Optoelectronic: red, sim to CITIZEN CL-150UR-CD.
CD111	B19/5TZET00009	Optoelectronic: orange, sim to CITIZEN CL-150D-CD.
CD112	B19/5TZET00022	Optoelectronic: red, sim to CITIZEN CL-150UR-CD.
CD113	B19/5TZET00009	Optoelectronic: orange, sim to CITIZEN CL-150D-CD.
CD114	B19/5TZET00022	Optoelectronic: red, sim to CITIZEN CL-150UR-CD.
CD115	B19/5TZET00009	Optoelectronic: orange, sim to CITIZEN CL-150D-CD.
CD116	B19/5TZET00022	Optoelectronic: red, sim to CITIZEN CL-150UR-CD.
CD117	B19/5TZET00009	Optoelectronic: orange, sim to CITIZEN CL-150D-CD.
CD118	B19/5TZET00022	Optoelectronic: red, sim to CITIZEN CL-150UR-CD.
CD119	B19/5TZET00009	Optoelectronic: orange, sim to CITIZEN CL-150D-CD.

SYMBOL	PART NO.	DESCRIPTION
CD120	B19/5TZET00022	Optoelectronic: red, sim to CITIZEN CL-150UR-CD.
CD121	B19/5TZET00009	Optoelectronic: orange, sim to CITIZEN CL-150D-CD.
CD122	B19/5TZET00022	Optoelectronic: red, sim to CITIZEN CL-150UR-CD.
CD123	B19/5TZET00009	Optoelectronic: orange, sim to CITIZEN CL-150D-CD.
CD124	B19/5TZET00022	Optoelectronic: red, sim to CITIZEN CL-150UR-CD.
CD125	B19/5TZET00009	Optoelectronic: orange, sim to CITIZEN CL-150D-CD.
CD126	B19/5TZET00022	Optoelectronic: red, sim to CITIZEN CL-150UR-CD.
CD127	B19/5TZET00009	Optoelectronic: orange, sim to CITIZEN CL-150D-CD.
CD128	B19/5TZET00022	Optoelectronic: red, sim to CITIZEN CL-150UR-CD.
CD129	B19/5TZET00009	Optoelectronic: orange, sim to CITIZEN CL-150D-CD.
CD130	B19/5TZET00022	Optoelectronic: red, sim to CITIZEN CL-150UR-CD.
CD131	B19/5TZET00009	Optoelectronic: orange, sim to CITIZEN CL-150D-CD.
CD132	B19/5TZET00022	Optoelectronic: red, sim to CITIZEN CL-150UR-CD.
CD133	B19/5TZET00009	Optoelectronic: orange, sim to CITIZEN CL-150D-CD.
CD134	B19/5TZET00022	Optoelectronic: red, sim to CITIZEN CL-150UR-CD.
CD135	B19/5TZET00009	Optoelectronic: orange, sim to CITIZEN CL-150D-CD.
CD136	B19/5TZET00022	Optoelectronic: red, sim to CITIZEN CL-150UR-CD.
CD137	B19/5TZET00022	Optoelectronic: red, sim to CITIZEN CL-150UR-CD.
CD138	B19/5TZET00022	Optoelectronic: red, sim to CITIZEN CL-150UR-CD.
CD139	B19/5TZET00009	Optoelectronic: orange, sim to CITIZEN CL-150D-CD.
CD140	B19/5TZET00022	Optoelectronic: red, sim to CITIZEN CL-150UR-CD.
----- INTEGRATED CIRCUITS -----		
IC101	B19/5DAAD00664	Linear: Positive Voltage Regulator; sim to TOSHIBA TA78L05F.
IC102 and IC103	B19/5DZAB00118	Digital, 8 BIT Shift Register; sim to TEXAS INSTRUMENTS SN74HC595ANSR.
----- CONNECTORS -----		
J101	B19/5JBAX00007	Connector: 30 pins.
J102	B19/5JWHZ00048	Connector: 9 pins.
----- INDUCTORS -----		
L101 thru L105	B19/5LCAA01306	Line Filter: Z=1800 ohms
L106 and L107	B19/5LCAA01307	Line Filter: Z=1600 ohms
L108 and L109	B19/5LCAA01306	Line Filter: Z=1800 ohms
L110 and L111	B19/5LCAA00787	Inductor: 10 uH ±10%.
----- RESISTORS -----		
R101	B19/5REAG01731	Metal film: 270 ohms ±5%, 100 VDCW 1/8W.
R102	B19/5REAG01744	Metal film: 3.3K ohms ±5%, 100 VDCW 1/8W.
R103	B19/5REAG01731	Metal film: 270 ohms ±5%, 100 VDCW 1/8W.
R104	B19/5REAG01744	Metal film: 3.3K ohms ±5%, 100 VDCW 1/8W.
R105	B19/5REAG01731	Metal film: 270 ohms ±5%, 100 VDCW 1/8W.
R106	B19/5REAG01744	Metal film: 3.3K ohms ±5%, 100 VDCW 1/8W.

SYMBOL	PART NO.	DESCRIPTION
R107	B19/5REAG01731	Metal film: 270 ohms $\pm 5\%$, 100 VDCW 1/8W.
R108 thru R116	B19/5REAG01744	Metal film: 3.3K ohms $\pm 5\%$, 100 VDCW 1/8W.
R117	B19/5REAG01733	Metal film: 390 ohms $\pm 5\%$, 100 VDCW 1/8W.
R118	B19/5REAG01744	Metal film: 3.3K ohms $\pm 5\%$, 100 VDCW 1/8W.
R119	B19/5REAG01731	Metal film: 270 ohms $\pm 5\%$, 100 VDCW 1/8W.
R120 thru R123	B19/5REAG01744	Metal film: 3.3K ohms $\pm 5\%$, 100 VDCW 1/8W.
		----- TRANSISTOR -----
TR101 thru TR116	B19/5TZCU00123	Silicon NPN: sim to ROHM DTC114EKAT146.

11.4 REMOTE INTERFACE ADAPTOR

Remote Interface Adaptor NQZ-4882C (Used in /12, /14)

SYMBOL	PART NO.	DESCRIPTION
		----- CAPACITOR -----
C3 and C4	B19/5CAAD02069	Ceramic: 1000pF + or - 10% 50 VDCW, temp coef + or - 15%.
C5	B19/5CBAB02416	Ceramic: 100pF + or - 5% 50 VDCW, temp coef + or - 60ppm.
C6 thru C10	B19/5CAAD02069	Ceramic: 1000pF + or - 10% 50 VDCW, temp coef + or - 15%.
		----- CONNECTORS -----
J1	B19/5JBAH00336	Connector: 25 Pins.
J2	B19/5JBAX00020	Connector: 18 Pins.
J3	B19/5JBAH00335	Connector: 25 Pins.

12 PRODUCTION CHANGE DATA

Changes in the equipment to improve performance or simplify circuits are identified by an “R-State”, which is stamped after the model number. The revision stamped on the unit includes all previous revisions. Refer to the Parts List for the description of parts affected by these revisions.

- Rev. R1A** **Control Head, Scan Local KRY 101 1632/11**
Control Head, Scan Local KRY 101 1632/17
Control Head, Scan Remote KRY 101 1632/12
Control Head, System Local KRY 101 1632/13
Control Head, System Remote KRY 101 1632/14
Control Head, System Remote KRY 101 1632/19
- Rev. -** **Panel Control Board, CMC-638C**
Switch Circuit Board, SCAN, B19/CDF-368BC
Switch Circuit Board, SYSTEM, B19/CDF-368MC
Initial Release
- Rev. R2A** **Control Head, Scan Local KRY 101 1632/11**
Control Head, Scan Remote KRY 101 1632/12
Control Head, System Local KRY 101 1632/13
Control Head, System Remote KRY 101 1632/14
Not released
- Rev. R1B** **Control Head, Scan Local KRY 101 1632/11**
Control Head, Scan Remote KRY 101 1632/12
Control Head, System Local KRY 101 1632/13
Control Head, System Remote KRY 101 1632/14
Production moved from plant in China to the JRC factory in Japan
- Rev. R3A** **Control Head, Scan Local KRY 101 1632/11**
Control Head, Scan Remote KRY 101 1632/12
Control Head, System Local KRY 101 1632/13
Control Head, System Remote KRY 101 1632/14
- Rev. R1B** **Panel Control Board, CMC-638C**
Switch Circuit Board, SCAN, B19/CDF-368BC
Switch Circuit Board, SYSTEM, B19/CDF-368MC
Changes made due to component obsolescence and product improvement.
On panel control head CMC-638C, changed:
- C201-C226 from B19/5CAAD00839 to B19/5CAAA05886
 - C227 and C228 from B19/5CAAD00952 to B19/5CAAD02363
 - C229, C230, C235, C238, C240, C241, and C256 from B19/5CAAD01586 to B19/5CBAB03556
 - C231, C232, C237, C239, C242 from B19/5CEAA03234 to B19/5CEAA04013
 - C233 and C254 from B19/5CAAA00838 to B19/5CBAB03656
 - C234, and C243-C247 from B19/5CAAD00839 to B19/5CAAA05886

- C236 from B19/5CEAA02858 to B19/5CBAB03626
- C248 and C255 from B19/5CAAD00959 to B19/5CBAB03625
- C249 from B19/5CAAD00839 to B19/5CAAD03707
- C251 from B19/5CEAA02912 to B19/5CEAA04475
- C252 from B19/5CEAA02888 to B19/5CEAA04091
- C257 from B19/5CSAA00336B to 19/5CSAA00347
- CD221 from B19/5TXCW00083 to B19/5TXCW00287
- IC202 from B19/5DDEH00013 to B19/5DDEH00128
- IC204 from B19/5DDAW00357 to B19/5DDAL03419
- IC205 from B19/5DAAJ00962 to B19/5DDAE01621
- IC206 from B19/5DADX00002 to B19/5DVBM00001
- IC207 from B19/5DAAN00055 to B19/5DVBG00061
- IC208 from B19/5DAAN00069 to B19/5DVBG00062
- IC210 and IC211 from B19/5TZA00346 to B19/5DZAD00343
- L201 and L202 from B19/5LCAT00008 to B19/5LCAT00102
- Added R249 because IC206 changed
- TR204 and TR205 from B19/5TCAZ00011 to B19/5TZCU00123

On Switch Circuit (CDF-368BC), changed

- C101, C102 and C103 from B19/5CAAD01586 to B19/5CBAB03556
- TR101, TR102, TR103, and TR104 from B19/5TCAZ00011 to B19/5TZCU00123
- R101 from B19/5RDAC02443 to B19/5REAG01733
- R102, R104, R106, R108 and R109 from B19/5RDAC02147 to B19/5REAG01744
- R103, R105, and R107 from B19/5RDAC02257 to B19/5REAG01734
- TR101–TR104 from B19/5TCAZ00011 to B19/5TZCU00123

On Switch Circuit (CDF-368MC), changed

- C101–C104 from B19/5CAAD01586 to B19/5CBAB03556
- C105–C111 from B19/5CAAD02263 to B19/5CAAD02069
- IC102 and IC103 from B19/5DAAJ01028 to B19/5DZAB00118
- R101, R103, R105, R107 and R119 from B19/5RDAC02163 to B19/5REAG01731
- R102, R104, R106, R108–R116, R118, and R120–R123 from B19/5RDAC02147 to B19/5REAG01744
- R117 from B19/5RDAC02443 to B19/5REAG01733
- TR101–TR116 from B19/5TCAZ00011 to B19/5TZCU00123

Rev. R3B

Control Head, Scan Local KRY 101 1632/11

Control Head, Scan Remote KRY 101 1632/12

Control Head, System Local KRY 101 1632/13

Control Head, System Remote KRY 101 1632/14

Rev. R1C

Panel Control Board, CMC-638C

Changed the value of R254 on Panel Control Board from 10K ohms to 47K ohms to improve communication performance in the MRK vehicular repeater applications.

Added lock washers to control unit switches (volume and channel or group/select) to eliminate breakage of flex circuit.

- Rev. R4A** **Control Head, Scan Local KRY 101 1632/11**
Control Head, Scan Remote KRY 101 1632/12
Control Head, System Local KRY 101 1632/13
Control Head, System Remote KRY 101 1632/14

- Rev. R2A** **Switch Circuit Board, SCAN, B19/CDF-368BC**
Switch Circuit Board, SYSTEM, B19/CDF-368MC

Added red plastic scan keycap with “triangle” symbol (part # 19C852359P8).

Added “E” keycap (part # 19C852359P9)

On Switch Circuit Board B19/CDF-368MC, CD137 changed from B19/5TZET00009 to B19/5TZET00022.

On Switch Circuit Board B19/CDF-368BC, CD113 and CD114 changed from B19/5TZET00009 to B19/5TZET00022.

- Rev. R4B** **Control Head, Scan Local KRY 101 1632/11**
Control Head, Scan Remote KRY 101 1632/12
Control Head, System Local KRY 101 1632/13
Control Head, System Remote KRY 101 1632/14

Applied a layer of non-conductive paint to the reinforced board of the control unit to resolve lock and self-PTT issues

Control Head, Scan Local KRY 101 1632/17

Control Head, Scan Remote KRY 101 1632/19

There was no physical change to the product; however, the revision was advanced from R1A to R4B to facilitate manufacturing.

13 INTERCONNECTION DIAGRAMS

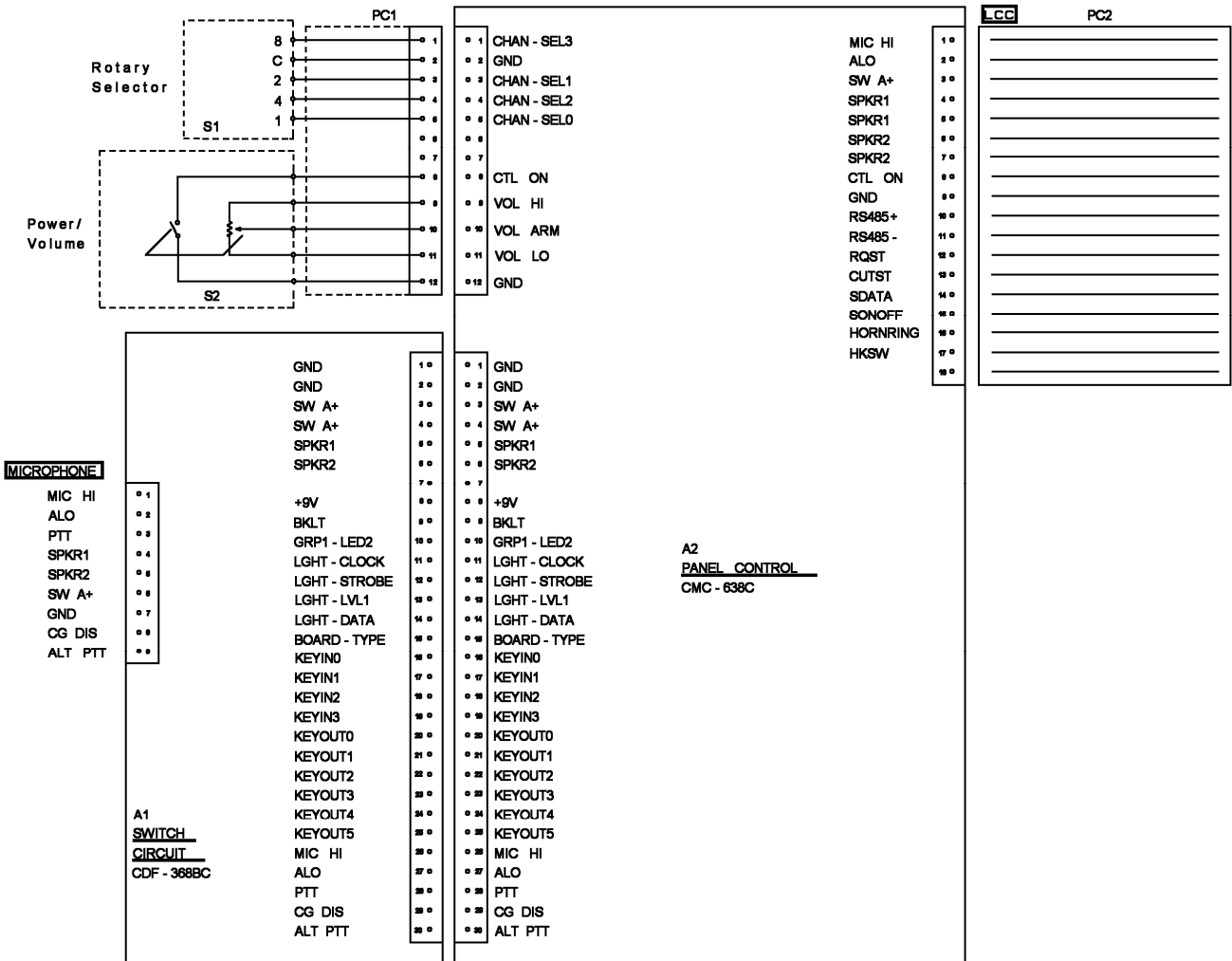

Figure 13-1: Control Unit (Scan Local) (ED00-CMD-556BLC)

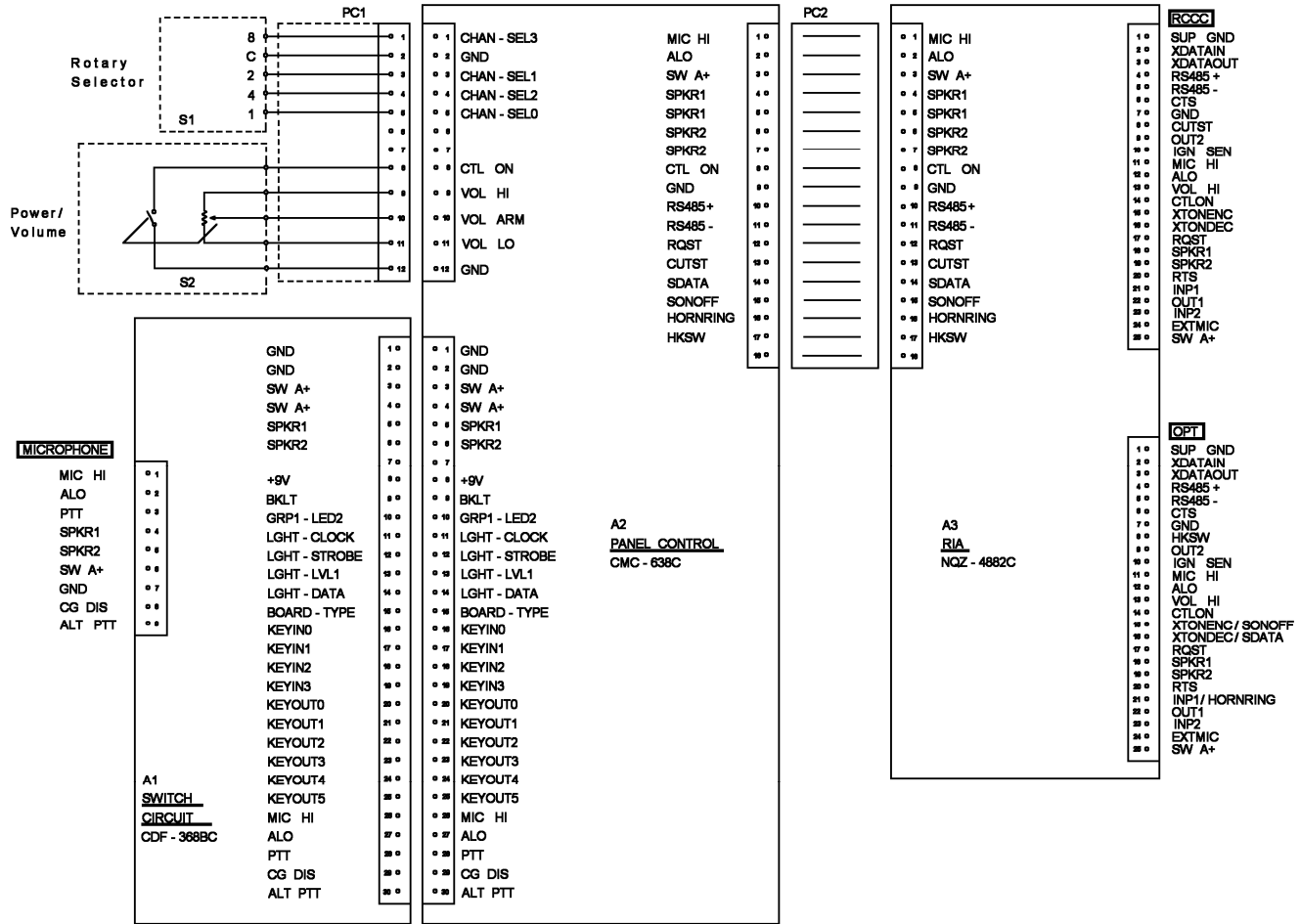

Figure 13-2: Control Unit (Scan Remote) (ED00-CMD-556BRC)

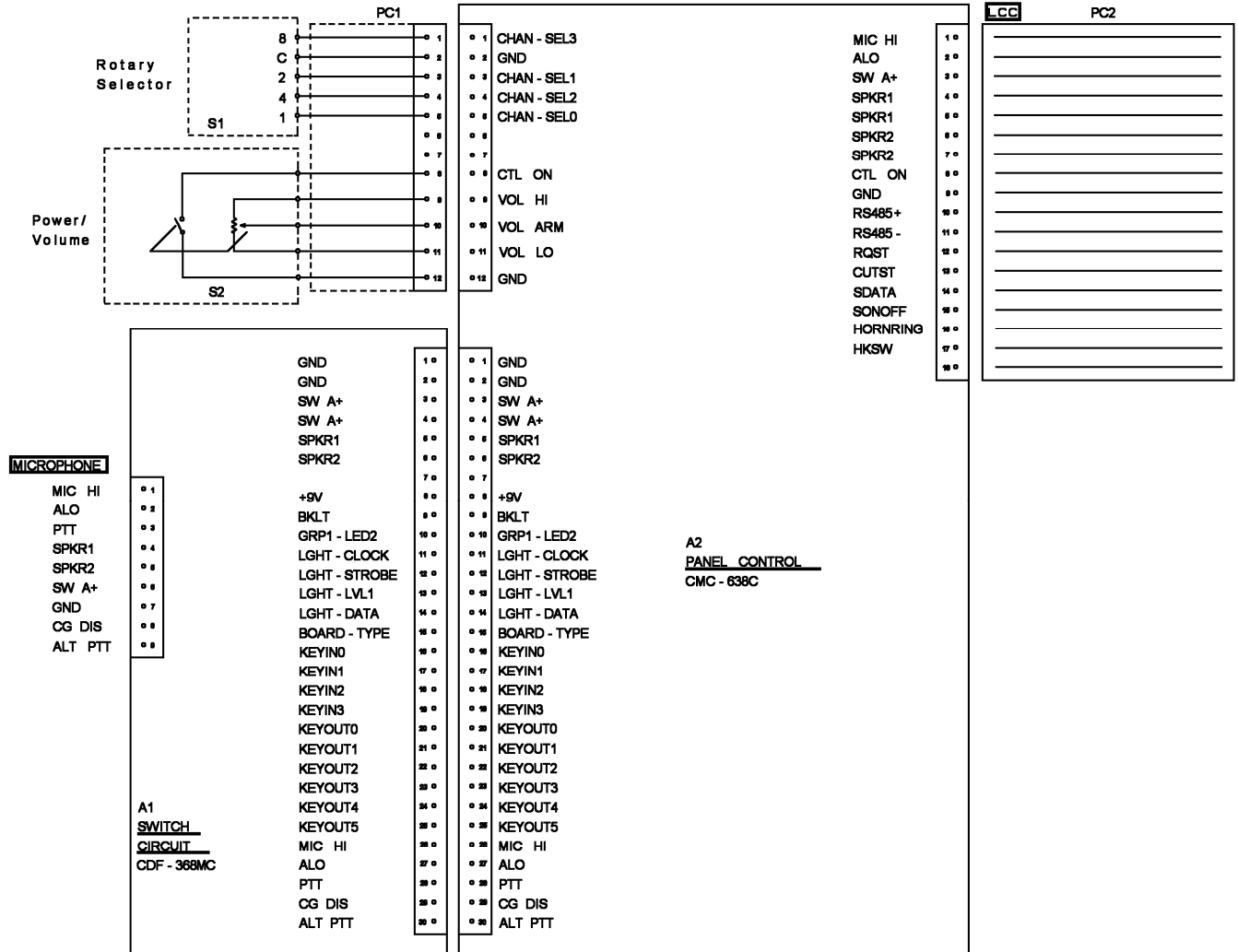

Figure 13-3: Control Unit (System Local) (ED00-CMD-556MLC)

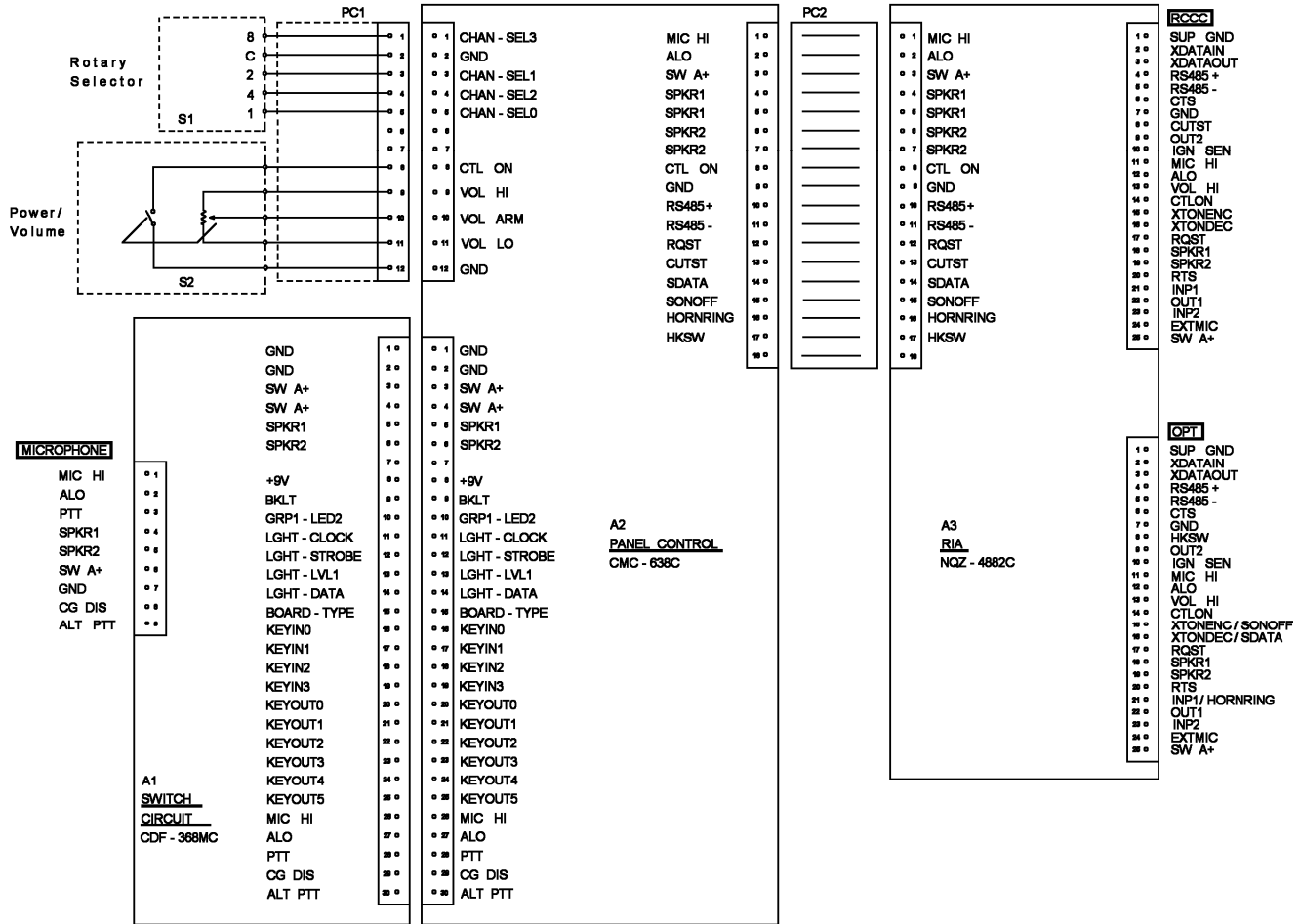
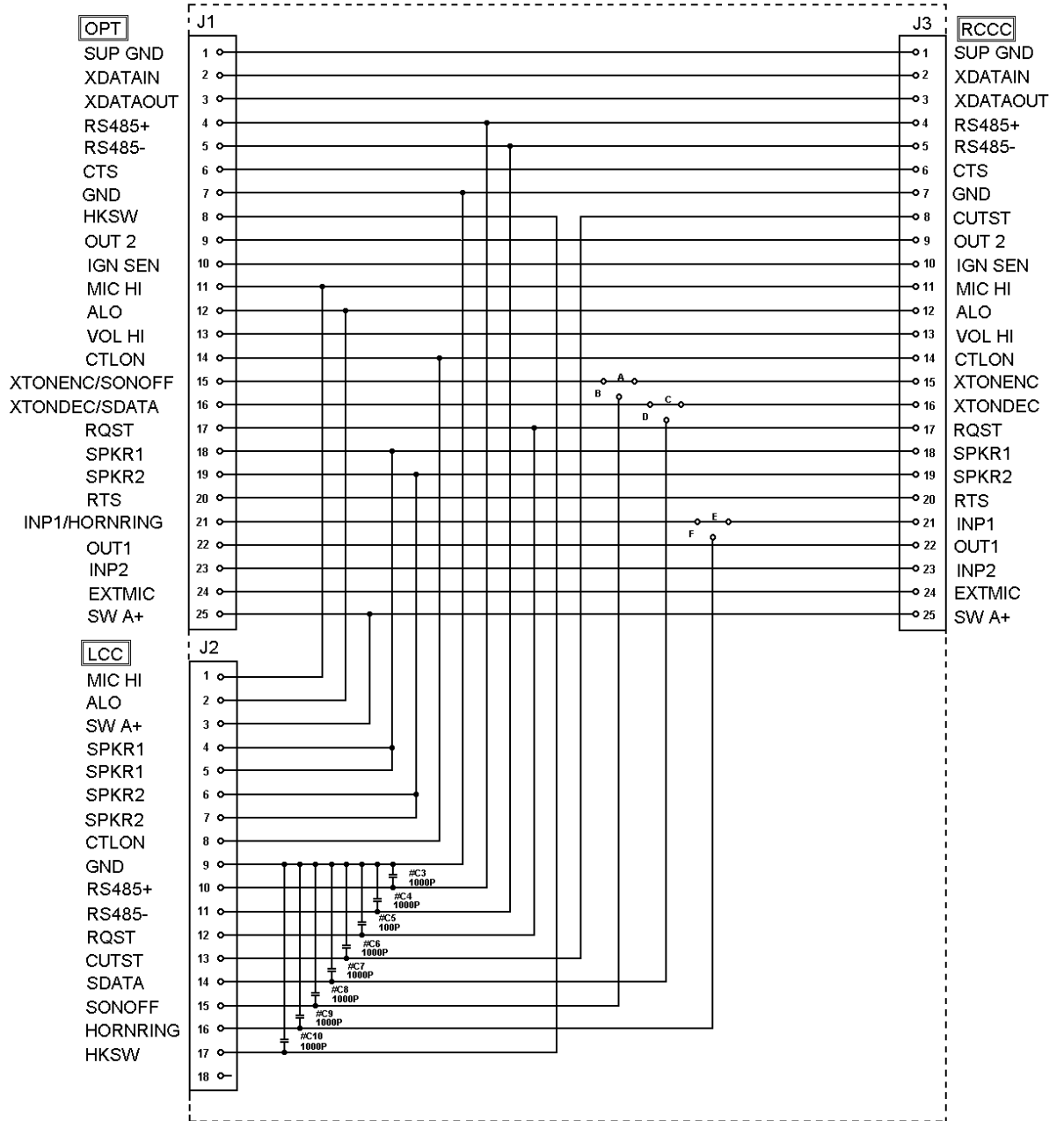

Figure 13-4: Control Unit (System Remote) (ED00-CMD-556MRC)

14 SCHEMATIC DIAGRAMS



ASM NO. B19-NQZ4882ZZ - ZZZAB
 PCB NO. B19-6PCLD00304D
 (6PCLD00169D)

REMOTE INTERFACE ADAPTER
NQZ-4882C
 (ED00-NQZ-4882C)

This page intentionally left blank

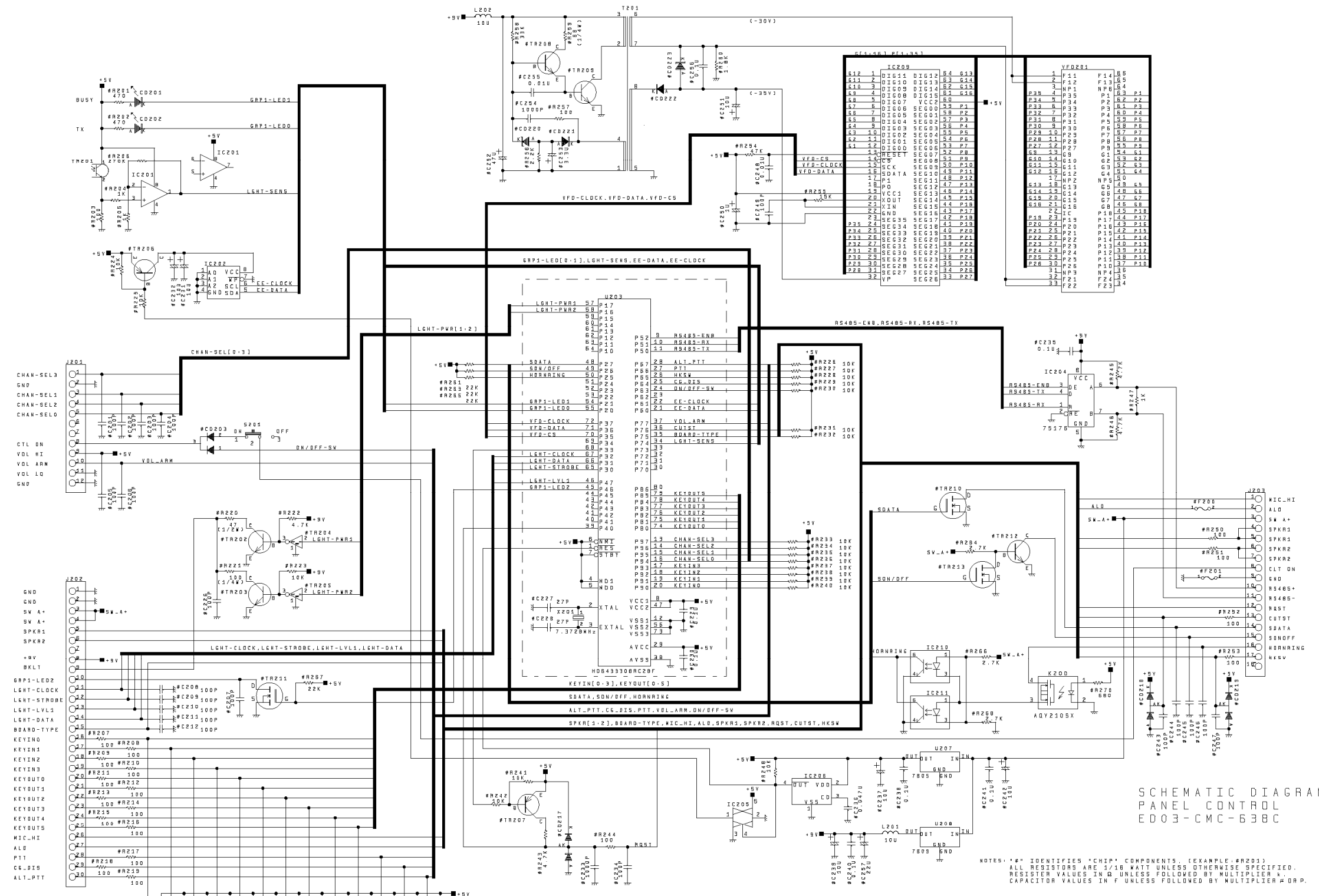

SCHMATIC DIAGRAM
Panel Control Board
ED03-CMC-638C

NOTES: ** IDENTIFIES CHIP COMPONENTS. (EXAMPLE: R200)
ALL RESISTORS ARE 1/16 WATT UNLESS OTHERWISE SPECIFIED.
RESISTOR VALUES IN Ω UNLESS FOLLOWED BY MULTIPLIER X, K, OR M.
CAPACITOR VALUES IN P UNLESS FOLLOWED BY MULTIPLIER μ OR P.

SCHMATIC DIAGRAM
Panel Control Board
ED00-CMC-638C

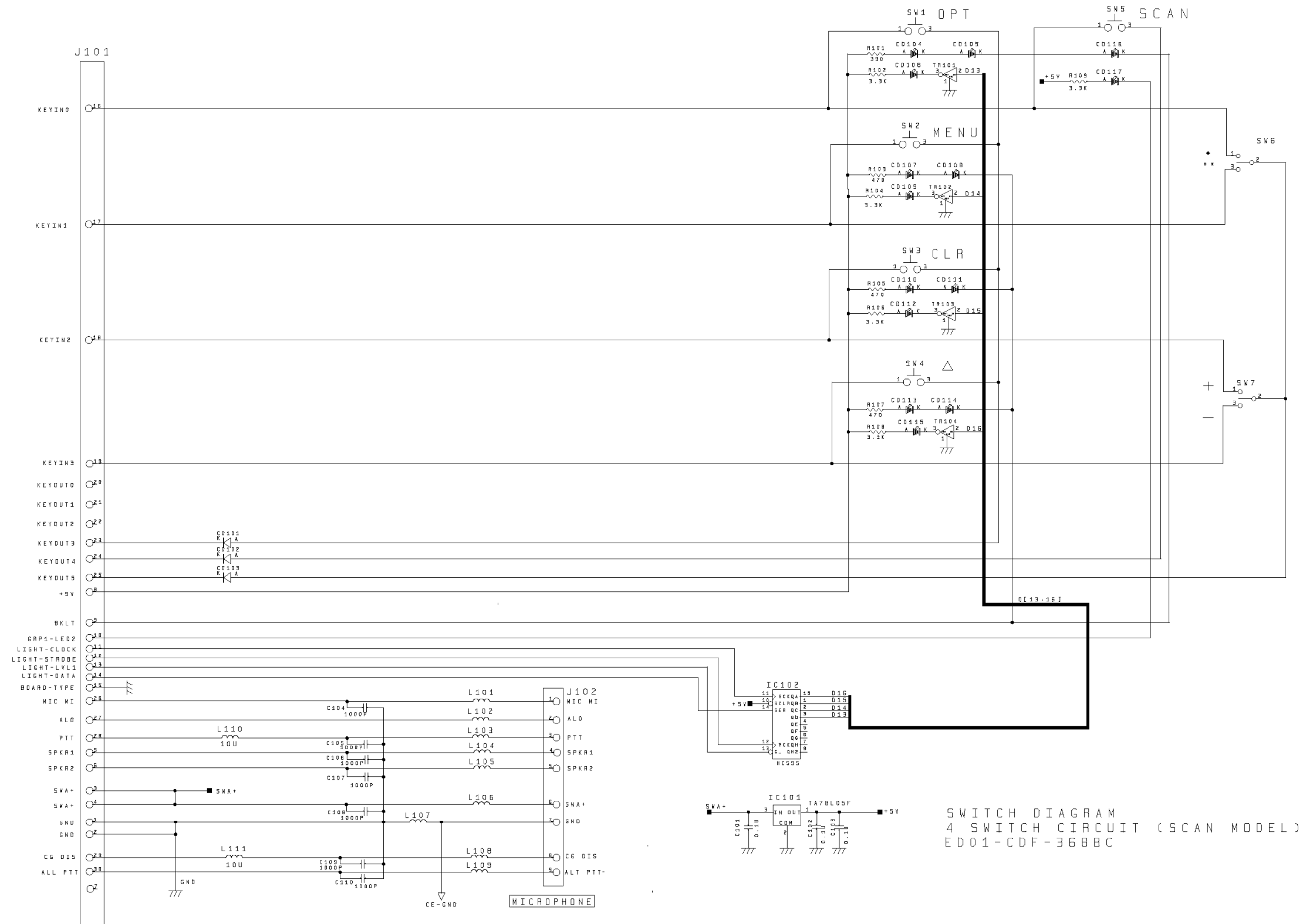

SWITCH DIAGRAM
4 SWITCH CIRCUIT (SCAN MODEL)
ED01-CDF-368BC

IDENTIFIES "CHIP" COMPONENTS (EXAMPLE: #R101)
ALL RESISTORS ARE 1/16 WATT UNLESS OTHERWISE SPECIFIED
RESISTOR VALUES IN UNLESS FOLLOWED BY MULTIPLIER K
CAPACITOR VALUES IN UNLESS FOLLOWED BY MULTIPLIER

SCHEMATIC DIAGRAM
Switch Circuit (Scan Model)
ED01-CDF-368BC

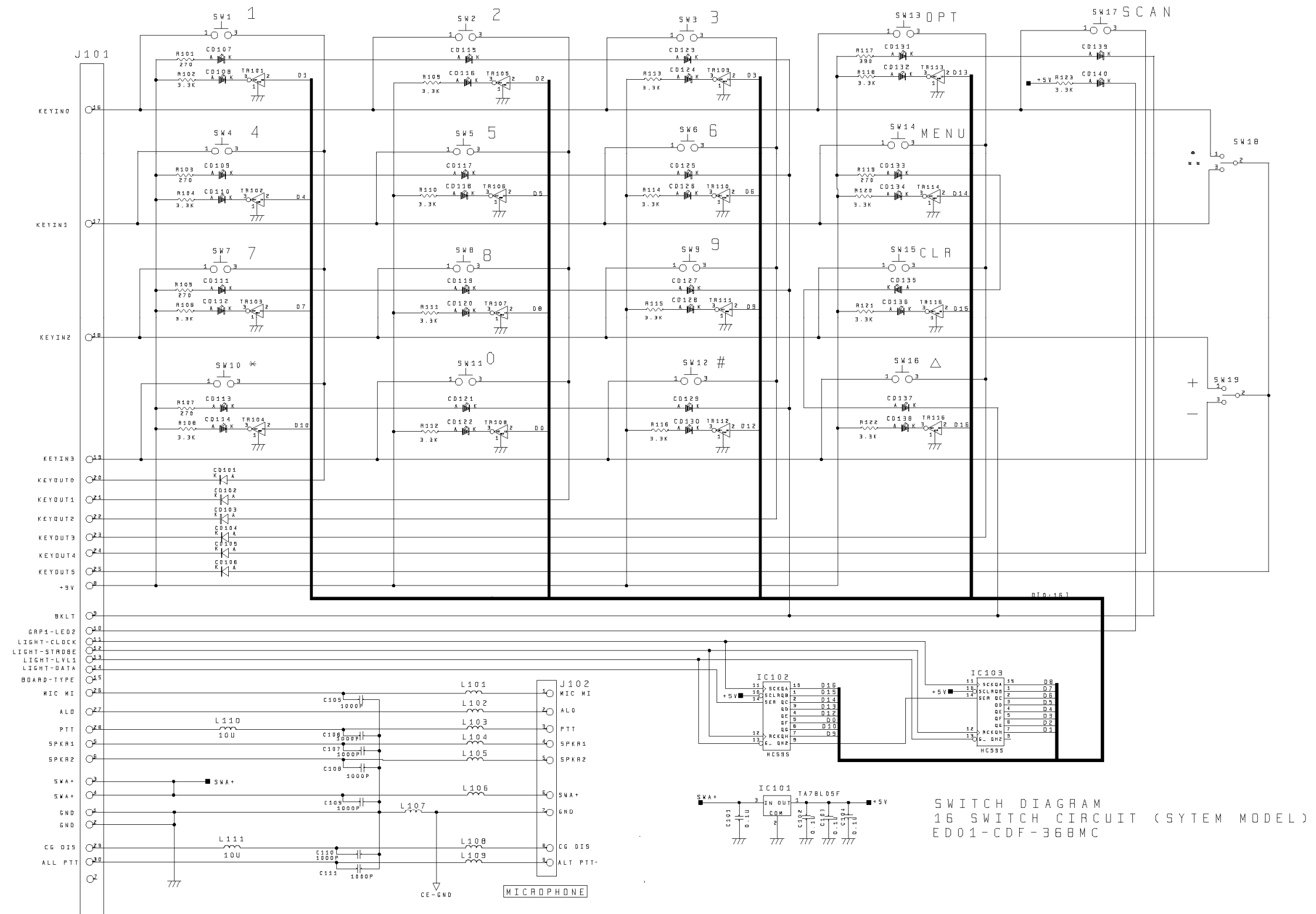

SWITCH DIAGRAM
16 SWITCH CIRCUIT (SYSTEM MODEL)
ED01-CDF-368MC

*# IDENTIFIES "CHIP" COMPONENTS (EXAMPLE: #R101)
ALL RESISTORS ARE 1/16 WATT UNLESS OTHERWISE SPECIFIED
RESISTOR VALUES IN UNLESS FOLLOWED BY MULTIPLIER K
CAPACITOR VALUES IN UNLESS FOLLOWED BY MULTIPLIER

SCHEMATIC DIAGRAM
Switch Circuit (System Model)
ED01-CDF-368MC



Tyco Electronics Wireless Systems
221 Jefferson Ridge Parkway
Lynchburg, Virginia 24501
(Outside USA, 1-434-385-2400) Toll Free 1-800-528-7711
www.macom-wireless.com

Printed in U.S.A.