

Maintenance Manual

M-PA™ VHF PORTABLE FM RADIO



TABLE OF CONTENTS

REAR COVER ASSEMBLY	LBI-38597
FRONT COVER ASSEMBLY (EARLIER) AND CONTROL BOARD	LBI-38384
FRONT COVER ASSEMBLY (LATER) LESS CONTROL BOARD	LBI-38834
CONTROL BOARD (LATER)	LBI-38828
VHF SERVICE SECTION	LBI-38385

TABLE OF CONTENTS

	<u>Page</u>
SPECIFICATIONS	3
OPTIONS AND ACCESSORIES	4
INTRODUCTION	5
FEATURES	5
DESCRIPTION	6
REAR COVER ASSEMBLY	8
FRONT COVER ASSEMBLY	8
ANTENNAS	8
BATTERY PACKS	8
UNIVERSAL DEVICE CONNECTOR	9
PROGRAMMING	
FEATURES PROGRAMMABLE ON A PER CHANNEL BASIS	9
FEATURES PROGRAMMABLE ON A PER MODE BASIS	9
FEATURES PROGRAMMABLE ON AN OVERALL RADIO BASIS	9
OPERATOR MANUAL	11
OPERATING TIPS	11
INTRINSICALLY SAFE USAGE	11
BATTERY PACKS	11
ACCESSORIES	11
MAINTENANCE	12
PREVENTIVE MAINTENANCE	12
DISASSEMBLY/ REASSEMBLY	13
ILLUSTRATIONS	
Figure 1 - System Model	7
Figure 2 - Scan Model	7
Figure 3 - Select Model	7
Figure 4 - Side View (All Models)	7
Figure 5 - UDC Pin-Out	10
Figure 6	13
Figures 7, 8 - Disassembly/Reassembly Diagrams	14
Figures 9, 10 - Disassembly/Reassembly Diagrams	15
Figure 11 - Rear Cover Assembly Block Diagram	16
Figure 12 - Front Cover Assembly (Earlier) And Control Board Block Diagram	17
Table 1 -VHF Antennas	8
Table 2 - UDC Pin Functions	10
Table 3 - Torque Specifications	13

NOTICE

This manual covers Ericsson and General Electric products manufactured and sold by Ericsson Inc.

NOTICE

Repairs to this equipment should be made only by an authorized service technician or facility designated by the supplier. Any repairs, alterations or substitution of recommended parts made by the user to this equipment not approved by the manufacturer could void the user's authority to operate the equipment in addition to the manufacturer's warranty.

NOTE

The software contained in this device is copyrighted by Ericsson Inc. Unpublished rights are reserved under the copyright laws of the United States.

This manual is published by **Ericsson Inc.**, without any warranty. Improvements and changes to this manual necessitated by typographical errors, inaccuracies of current information, or improvements to programs and/or equipment, may be made by **Ericsson Inc.**, at any time and without notice. Such changes will be incorporated into new editions of this manual. No part of this manual may be reproduced or transmitted in any form or by any means, electronic or mechanical, including photocopying and recording, for any purpose, without the express written permission of **Ericsson Inc.**

SPECIFICATIONS***GENERAL**

Frequency Bands	<u>FCC TYPE</u>	<u>DOC</u>
146 - 162 MHz	AXATR-182-B5	TR-182-D2
157 - 174 MHz	AXATR-182-C5	TR-182-D2
136 - 150.8 MHz		
Frequency Stability	5.0 ppm	
Channel Capacity		
Select Model	16	
Scan Model	192	
System Model	192	
Maximum Frequency Separation	full bandsplit	
Channel Spacing	30 kHz	
Operating Temperature Range	-30°C to +60°C	
Maximum Relative Humidity	90% at 55°C	
Battery Voltage	7.5 Vdc (nominal)	
Dimensions (H x W x D)		
less battery, knobs and antenna	140 x 69 x 38 mm (5.52 x 2.72 x 1.50")	
with Extra High Cap. Battery	232 x 69 x 40 mm (9.15 x 2.72 x 1.58")	
Weight		
less battery and antenna	540 grams (19 ounces)	
with Extra High Cap. Battery	907 grams (32 ounces)	

TRANSMITTER

Rated RF Power Output	6.0 Watts
High / Low RF Power Output	6.0 Watts / 1 Watt (programmable per channel)
Maximum FM Deviation	±5 kHz
FM Hum and Noise	-45dB (companion receiver)
Spurious and Harmonic Emissions	-75 dBc
Audio Response	+1 to -3dB (6 dB/octave pre-emphasis from 300 Hz to 3 kHz)
Audio Distortion	less than 3% (at 1000 Hz tone, 3 kHz deviation)

RECEIVER

Sensitivity (12 dB SINAD)	-116 dBm (0.35 μV)
Adjacent Channel Selectivity	-80dB
Critical Squelch	10dB SINAD
Intermodulation	-78dB
Spurious and Image Rejection	-80dB
Audio Output	500 mW (24-ohm load impedance)
Audio Response	+2 to -8dB (6 dB/octave de-emphasis from 300 Hz to 3 kHz)
Audio Distortion	less than 5% (at 500 mW)

* These specifications are intended primarily for the use of the serviceman. See the appropriate Specifications Sheet for the complete specifications.

Radios, Antennas, Batteries

VHF	136-151 MHz	HELICAL ANTENNA	PANC1B
	146-162 MHz	HELICAL ANTENNA	PANC1C
	157-174 MHz	HELICAL ANTENNA	PANC1D
800MHz	378-440 MHz	WHIP ANTENNA	PANC1L
	378-440 MHz	HELICAL ANTENNA	PANC1U
	440-470 MHz	HELICAL ANTENNA	PANC1F
	470-494 MHz	HELICAL ANTENNA	PANC1G
	492-514 MHz	HELICAL ANTENNA	PANC1V
UHF	440-514 MHz	WHIP ANTENNA	PANC1K
	806-870 MHz	WHIP ANTENNA	PANC1K
	806-870 MHz	ELVFD ANTENNA	PANC1H

SELECT

SCAN

SYSTEM

OR

**EXTRA HIGH CAP. BATTERY
PAPA1F (INTRINSICALLY SAFE)
EXTRA HIGH CAP. BATTERY
PAPA1E**

**HIGH CAPACITY BATTERY
PAPA1G (INTRINSICALLY SAFE)
HIGH CAPACITY BATTERY
PAPA1H**

Carrying Accessories

**BELT CLIP
PAHC1C**

**SWIVEL MOUNT
PAHC1D**

**CARRYING CASE
WITH BELT LOOP
PAHC1E
WITH SWIVEL MT
PAHC3V
PAHC3W**

**SHOULDER
STRAP
PAHC1H**

**SWIVEL MOUNT PLATE
5203**

Audio Accessories

**HEADSET/MIC
PAAB1A**

**EARPIECE
PAAC1J**

**SPKR/MIC
PAAE3E**

**INTERFACE CONNECTOR
(PROVIDED WITH PAAB1A)**

**GE-STAR LANYARD
PAAC1B**

Chargers

UNIVERSAL MULTI-CHARGER
CH6RA1 120 VAC 1HR
CH6SA1 120 VAC 14HR
CH6RA2 230 VAC 1HR
CH6SA2 230 VAC 14HR

MULTI-CHARGER
H2A2L2A 120 VAC 14HR
H2A2J1A 120 VAC 1HR
H2A2M2A 240 VAC 14HR
H2A2N1A 240 VAC 1HR

UNIVERSAL DESK CHARGER
CH1RA1 120 VAC 1HR
CH1SA1 120 VAC 14HR
CH1RA2 230 VAC 1HR
CH1SA2 230 VAC 14HR

COMPACT CHARGER
H2A5C2A - Vehicular Charger
H2A6L2A - Desk Charger

VEHICULAR CHARGER
H2V01 - Vehicular Charger
H2V02 - Vehicular Chgr / Rptr Control

INTRODUCTION

The M-PA radio is a high quality microprocessor controlled synthesized portable FM radio. M-PA operation is highlighted by the radio's programming versatility. This allows tailored operation of the portable radio to meet the needs of the radio system and the individual users. Three (3) different M-PA radio models are available: Select, Scan and System.

The M-PA Select model radio is the basic version that can be programmed with up to sixteen (16) channels. This unit features an 8-digit alphanumeric liquid crystal display (LCD) and a 16-position knob for channel selection. The display is backlit for nighttime and low-level ambient light operation.

Scan and System model radios have an LCD similar to the Select model radio. A keypad is added to these radios (4-button on Scan model, 16-button on System model) to provide additional features not available on the Select model radio. These radios can be programmed with up to 192 different radio channels. Both also provide scan capability including dual-priority scan, and DTMF telephone interconnect of up to ten (10) preprogrammed numbers. The telephone numbers can be recalled at will and initiated. The System model's numeric keypad allows editing of the ten preprogrammed numbers and manual DTMF telephone inter-connect dialing.

FEATURES

- **192-Channel Capability** - Scan and System models radios can be programmed with up to 192 channels accessed in 12 modes (banks of channels) with 16 channels in each mode or 16 modes with 12 channels in each mode. The Select model radio can be programmed with a maximum of 16 channels.
- **Backlit Liquid Crystal Display** - The 8-digit alphanumeric LCD provides programmable customization and feedback to the operator of various operating conditions. Status flags located above and below the digits alert the operator to various radio conditions such as channel busy, transmitter in operation, or a low battery condition. Scan and System model radios have additional status flags for scan operation. LCD backlighting can be enabled or disabled on a per channel basis.
- **Rotary Control Knob** - On Scan and System model radios, the 16-position top-mounted Control Knob allows easy selection of modes (banks of channels), channels or Channel Guard (CG) according to how the radio is programmed. On the Select model radio, the Control Knob selects the operating channel. A stop-plate may be installed under the knob to limit the maximum number of positions to less than sixteen (16). It is normally factory installed for fifteen (15) positions.
- **Volume Control Knob** - This rotatable control provides quick and easy adjustments to the volume level. Minimum volume levels can be programmed into the unit. This feature prevents missed calls due to a low volume setting.
- **Monitor Button** - This side-mounted button is used to disabled squelch and if programmed for the selected channel, it is used to toggle CG and/or T99 operation on and off.
- **Keypad** - The Scan model radio has a 4-button keypad on its front panel that provides scan and menu control. The menus allow selection of the current operating mode (bank of channels) and/or channel depending upon the radio's programming. The menus also allow control of various other radio features such as selection of stored telephone interconnect numbers for auto-dial operation, and alert tone enable/disable control. A System model radio has a 16-button keypad. The top four (4) buttons are identical to the Scan model keypad, providing scan and menu control. The lower twelve (12) buttons form a numeric keypad that allows manual DTMF telephone interconnect dialing and editing of telephone interconnect numbers stored in the radio. Select model radios do not have a keypad.
- **Scan Capability** - Scan and System model radios can be programmed for non-priority scan or dual-priority scan operation. Scan programming options include a keypad entered scan list or a fixed scan list. Priority scan programming options include a fixed priority-one channel or the selected channel as the priority-one channel. The radio can be programmed to scan only the channels in the current mode (bank of channels) or it may be programmed to scan across modes. The Select model radio does not support scan operation.
- **Telephone Interconnect Capability** - The Scan and System model radios can store up to ten (10) telephone interconnect numbers for auto-dial operation. These numbers are preprogrammed into the Scan model radio. In the System model radio, the numbers can be preprogrammed, operator-entered and/or edited via the numeric keypad. The System model's numeric keypad also allows manual DTMF tele phone interconnect dialing. The Select model radio cannot initiate telephone interconnect calls.

- **Programmable Multi-Tone Channel Guard (CTCSS)** - Channel Guard tone frequencies within the range of 67 Hz to 210.7 Hz, including all of the standard EIA frequencies, can be programmed for encoded/decoded operation.
- **Programmable Multi-Code Digital Channel Guard** - Similar capability as with tone Channel Guard is provided.
- **Two-Tone Sequential (T99) Decode** - Selective calling decode is enabled or disabled on each individual channel. Two (2) sets of unique de-codes are programmable to allow large systems individual and group call capability. Sets are selectable on a mode (bank of channels) basis.
- **Channel Busy Lockout** - Personality information includes transmit disable capability on a channel where carrier activity is present This feature is selectable on a per channel basis.
- **GE-STAR Compatibility** - The radio can be programmed to transmit GE-STAR at PTT key, at PTT unkey, or both. 16,384 individual ID codes are available.
- **Emergency Signalling Feature** - GE-STAR emergency signalling can be enabled by the red Emergency/Home Button on the top of the radio or it can be enabled by a lanyard connected to the UDC.
- **Home Button** - The radio can be programmed to switch to a home mode or channel (depending on Control Knob's programming) when the red Emergency/Home Button on the top of the radio is pressed.
- **Programmable Carrier Control Timer** - A programmable transmit timer will automatically disable the transmitter and provide an alerting tone after time-out. This feature prevents radio damage and unnecessary channel traffic in the event of a "stuck" mic. The CCT is reset on every PTT.
- **Programmable Transmit Power Level** - Transmitter power level is PC programmable into the radio (high or low) on a per channel basis.
- **Squelch Tail Elimination** - Squelch and audio circuits are designed so that annoying squelch pops which may occur at the end of received messages are minimized. This feature is compatible with existing STE systems.
- **Alert Tones** - Alert tones prompt the operator of various radio conditions such as key pressed, CCT time-out or a low battery.
- **Power-Up Self-Test** - At power-up the radio automatically performs a diagnostic test on itself and reports any found errors via the LCD.
- **Programmable via the Universal Device Connector (UDC)** - The entire operation of the radio can be field customized by programming the unit using an IBM PC or compatible computer. The programmed personality is stored in nonvolatile memory within the radio.
- **Simple Remote Control Capability** - External accessories can be connected to the UDC such as a headset, a speaker-mic or a lanyard. Connection of the speaker-mic allows the operator to remotely control PTT operation and audio level of the external speaker. An antenna jack is located on the UDC for the connection of a remote mounted antenna such as when the radio is used in a vehicular charger.
- **Meets MIL-810C and D Specifications** - The sturdy die-cast aluminum case is designed to seal out moisture, blowing rain and other harsh environmental factors.
- **Battery Packs** - Several different battery pack sizes and capacities are available.
- **Available Options** - These options include the antennas, audio accessories, batteries, carrying accessories, chargers, lanyards, and the vehicular chargers.

DESCRIPTION

Two major assemblies form an M-PA radio. The Front Cover Assembly contains all of the microprocessor circuitry, audio circuitry and the operating controls. The Rear Cover Assembly houses the RF circuitry which includes the transmitter, receiver and the frequency synthesizer. The assemblies are electrically interconnected by two single-in-line type connectors. When mated together, the assemblies form a weather resistant diecast aluminum case that protects the radio's circuitry from harsh outside environments.

Power is provided by a battery pack that slides and locks on to the bottom of the radio. The radio's on/off switch is located on the battery pack.

The antenna screws on to the top of the unit A side antenna connection is also provided at the UDC for an external antenna or for test purposes. This UDC antenna connection is also utilized for external antenna operation when the radio is locked in the vehicular charger.



Figure 1 - System Model



Figure 2 - Scan Model



Figure 3 - Select Model

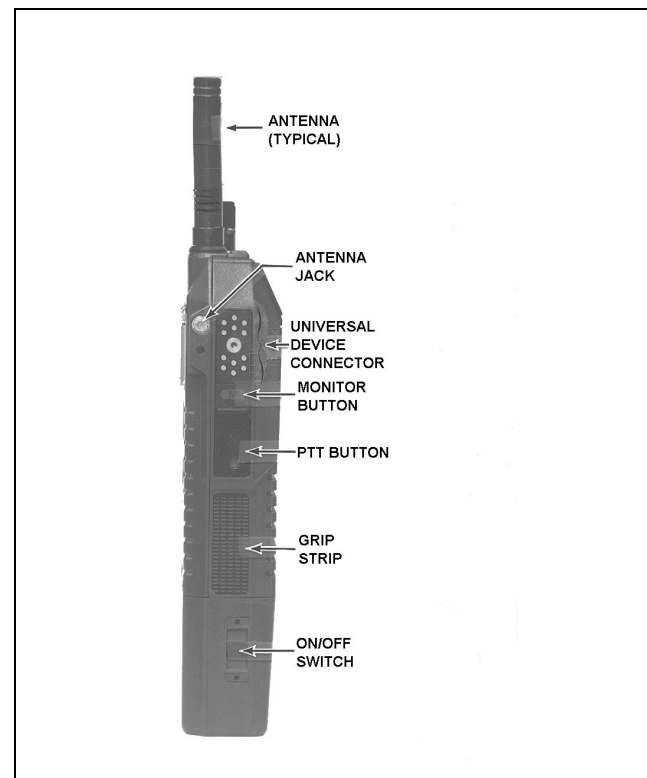

Figure 4 - Side View (All Models)

REAR COVER ASSEMBLY

The Rear Cover Assembly houses the RF Board in the die-cast aluminum case. The complete assembly consists of the VHF RF Board, aluminum case, top antenna jack, side (UDC) antenna jack and various hardware.

The RF Board's circuitry includes the transmitter, receiver and the frequency synthesizer. This FM circuitry is under complete control of the microprocessor circuits. Controlling data sent to this assembly from the Control Board includes serial synthesizer data loading, transmitter/receiver enabling and a transmitter power level signal. The RF Board outputs the demodulated audio and a synthesizer lock status line to the Control Board. During transmitter operation, the RF power appears at the top antenna jack (or the UDC jack if the appropriate adapter plug is inserted). The Rear Cover Assembly maintenance manual contains a detailed circuit analysis, mechanical, outline and schematic diagrams for this assembly.

FRONT COVER ASSEMBLY

The Front Cover Assembly houses all of the operating controls and the digital control circuitry for the radio. Board assemblies used in this assembly include the Control and LCD Boards and flex circuits include the Keypad, UDC and Speaker Flex circuits. The speaker, microphone and Battery Plate are also a part of this assembly. The complete assembly is housed in the die-cast aluminum front cover. Scan and System model radios are equipped with a keypad on the front panel.

The Control Board located in the Front Cover Assembly is the largest and most complex board in the Front Cover Assembly. It contains all microcomputer and audio circuitry which controls the radio. See the maintenance manuals specific to the Control Board or the Front Cover Assembly for service information on the related assembly.

ANTENNAS

Antennas are selected based on the operating frequency range of the radio. Table 1 lists the available antennas which mount in the antenna jack on the top of the radio. An exter-

nal antenna can be mounted to the unit via the UDC. When an antenna is connected to the UDC, the antenna on the top of the radio is disabled.

BATTERY PACKS

The battery pack connects to the bottom of the unit and delivers a nominal 7.5 Volts dc to the radio. A recessed on/off switch for the radio is located on the battery pack. An internal fuse located in the radio's Battery Plate protects the radio and battery from excessive current draw. The battery packs are available in several different capacities and sizes.

Radio contacts located on the top of the pack include switched power, ground, the speaker enabling contacts and a continuous power contact. In addition, four contacts are located on the rear of the battery pack. These four contacts provide connections to the slip-in type chargers or vehicular chargers/repeaters while the battery pack is still connected to the unit. The battery charging contacts are diode protected from external shorts.

The chargers utilize an internal thermistor in the battery pack to sense temperature and automatically control charge rate of the battery. This allows for a maximum charge rate without overheating the battery pack. All battery packs can be charged in less than 1 1/2 hours with the rapid type chargers. Nominal full charge time in a standard charger is 14 hours. The Service Section contains a detailed outline and schematic diagram of a typical battery pack. Further service information for the battery packs is also presented in the Service Section.

Chargers are available with nominal charge times of one hour (rapid) and fourteen hours (standard). Combinations include single (1) and multi (5 or 6) position, standard and rapid charge units. In addition, the vehicular chargers simultaneously charge the battery while the radio is operating.

The battery packs should be fully charged in an appropriate charger before they are placed into service. This applies to new battery packs received from the factory and to battery packs that have been stored for long periods of time. A fully charged battery pack should have an open-terminal voltage greater than 7.5 Volts (typically 9.0 Vdc). A battery

TABLE 1 -VHF ANTENNAS

USABLE FREQ. RANGE (MHz)	OPTION NUMBER	PART NUMBER	TYPE	COLOR BANDS
136-151	PANC1B	19B234804P1	Helical	Brown
146-162	PANC1C	19B234804P2	Helical	Red
157 - 174	PANC1D	19B234804P3	Helical	Orange

pack in need of a charge will cause the low battery "BAT" status flag on the radio to turn on. This flag will turn on when the battery pack's voltage drops below approximately 6.8 Volts. The low battery alert tone will also be heard when the battery pack needs charging.

RECHARGEABLE BATTERY PACK DISPOSAL



The product that you have purchased contains a rechargeable battery. The battery is recyclable. At the end of its useful life, under various state and local laws, it may be illegal to dispose of this battery into the municipal waste stream. Check with your local solid waste officials for details in your area for recycling options or proper disposal. Call Toll Free 1-800-8-BATTERY for information and /or procedures for returning rechargeable batteries in your state.

UNIVERSAL DEVICE CONNECTOR

The UDC is located on the side of radio just above the PTT and Monitor Buttons. Various equipment such as the audio accessories can be connected to the radio via the UDC. The programming equipment is also connected to it when the personality is programmed into the radio. The UDC furnishes an excellent first-check-point for initial bench checks without the need to disassemble the radio. Table 2 lists all pins and their appropriate function. When the radio is turned on it senses the resistance value between UDC pins 9 and 1 and switches the appropriate circuits to provide proper radio-to-accessory operation.

PROGRAMMING

The radio's personality is programmed using an IBM PC or compatible computer. A full-screen portable PC can be used for field programming. The Programming Manual and Software is TQ-3339 and TQ-4339. TQ-3339 is supplied with 5-1/4 inch floppy disks and TQ-4339 is supplied with 3-1/2 inch disks. This software uses a series of screens and windows to guide you through a programming session. See TQ-3339 or TQ-4339 for further programming details. PC Programming Adapter TQ-3370 and Programming Cable TQ-3311 will also be required. These items provide interface and connection between the PC and the radio when the personality is transferred from the PC into the radio.

NOTE

After programming or reprogramming the radio, disconnect the programming cable and turn the radio off and then back on. This action will take the radio out of programming mode and restore normal operation.

FEATURES PROGRAMMABLE ON A PER CHANNEL BASIS

- Transmit and Receive Frequencies
- 8-Character Alphanumeric Display (Channel Designator)
- Tone or Digital Channel Guard Encode/Decode
- Type 99 Tone Decode Enabled or Disabled
- Transmit Power Level High or Low
- Transmit STE On or Off
- Channel Busy Lockout Enabled or Disabled
- Carrier Control Timer
- Backlight On or Off
- Alert Tones On or Off
- Switch Crystal Frequency Enabled or Disabled
- GE-STAR Enabled or Disabled
- GE-STAR sent with Channel Guard
- Channel on Default/Fixed Scan List*

FEATURES PROGRAMMABLE ON A PER MODE BASIS*

- Channel Data
- 8-Character Alphanumeric Display (Mode Designator)
- Type 99 Group Set Selection (One or Two)
- Priority-One and Priority-Two Scan Channels
- DTMF Enabled or Disabled
- GE-STAR Channel
- Home Channel

FEATURES PROGRAMMABLE ON AN OVERALL RADIO BASIS

- Minimum Volume Level
- Power-Up Beep On or Off
- Transmit Backlight On or Off
- Backlight On or Off when in Vehicular Charger
- GE-STAR And GE-STAR Emergency Options

TABLE 2 - UDC PIN FUNCTIONS

PIN	NAME	INPUT OR OUTPUT	USE
1	GROUND	-----	Case Ground
3	UDC RX AUDIO	Output	Test Point For Speaker Audio
4	SWBATT	Output	Switched Accessory Power
5	EXT PTT	Input	External Microphone PTT Input
6	TX DATA	Input	For Programming
7	RX DATA	Output	For Programming
8	SPARE		
9	UDC VOLT	-----	Option/Accessory Sense Pin
10	T/R	Output	Low = Transmit, High = Receive
11	UDC MUTE	Output	Low = Audio Muted
12	EXT MIC HI	Input	External Microphone Audio Input
13	EXT EMER	Input	Lanyard Connection
34	UDC DISCR	Output	Test Point For RX Audio

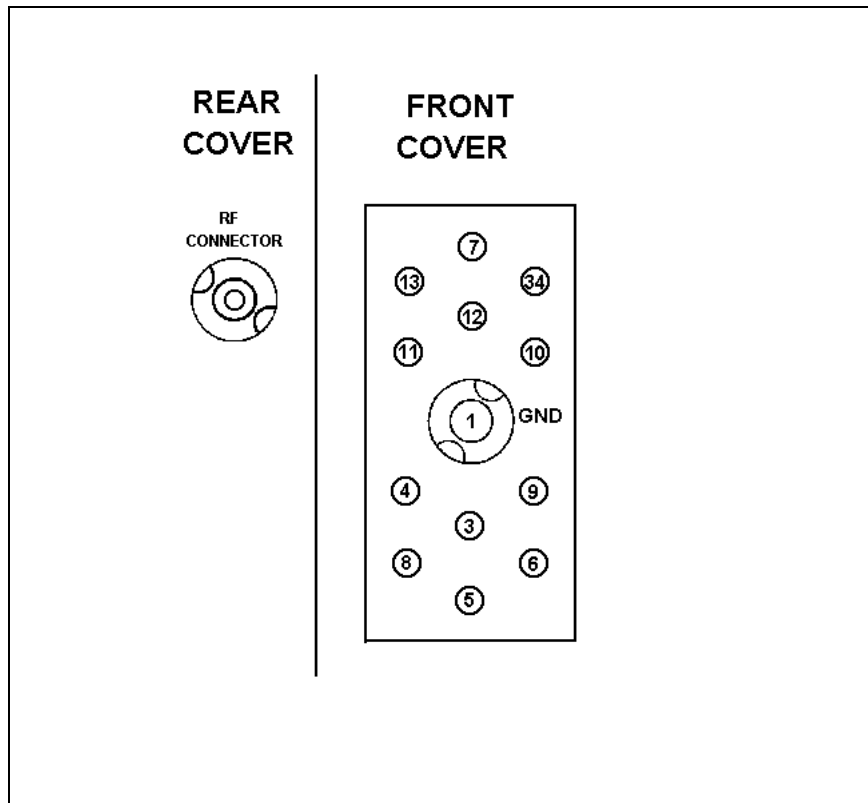

Figure 5 - UDC Pin-Out

- Two individual Type 99 Tone Group Sets
- Control Knob selects Channels, Modes or Channel Guard*
- Menu Selections*
- Home Mode or Home Channel (depending on Control Knob programming) or Disabled*
- Scan Enabled or Disabled*
- Scan with Channel Guard Enabled or Disabled*
- Scan Across Modes Enabled or Disabled*
- Priority-One Scan Channel is the Selected Channel, Fixed Channel or Keypad Entered Channel*
- Ten (10) Telephone Numbers and Names*
- DTMF Options*

* Scan and System models only

OPERATOR MANUAL

Complete operating details for the M-PA radios are included in LBI-38377. This operator's manual contains detailed operating procedures for the Select, Scan and System model radios.

OPERATING TIPS

Antenna location and condition is important when using a VHF radio. Operating the radio in low areas of terrain, under power lines or bridges, inside of a vehicle or in a metal or steel framed building can severely reduce the range of the unit. Mountains and buildings can also reduce the range of the unit.

In areas where transmission or reception is poor, some improvement may be obtained by insuring that the antenna is vertical. Moving a few yards in another direction or moving to a higher elevation may also improve communication. Vehicular operation can be aided with the use of an externally mounted antenna.

Battery condition is another critical factor in the trouble free operation of a portable radio. Observe the procedures listed in the Service Section to insure the battery packs do not develop the "Memory Effect".

Always observe all of the Federal Communication Commission's rules and regulations during any service or operating procedure.

INTRINSICALLY SAFE USAGE

Selected portable radios with appropriate factory installed F4 Options are certified as Intrinsically Safe by the Factory Mutual Research Corporation. Intrinsically Safe approval includes Class I, II, III, Division 1 hazardous locations in the presence of Groups C, D, E, F and G atmospheres. Non-Incendive approval includes Class I, Division 2 hazardous locations in the presence of Groups A, B, C and D atmospheres.

Hazardous locations are defined in the National Electrical Code. Useful standards NFPA 437A and NFPA 437M for the classifications of hazardous areas can be ordered from the National Fire Protection Association, Batterymarch Park, Quincy, MA 02269.

BATTERY PACKS

Only battery packs identified with a green latch shall be used with a portable radio that is rated and labeled as Factory Mutual Intrinsically Safe. Use of non-specified battery packs voids Factory Mutual approval. The following battery pack options are approved for use in intrinsically safe radios:

PAPA1F	Rechargeable Battery Pack, Extra High Capacity (Tall Case)
PAPA1G	Rechargeable Battery Pack, High Capacity (Short Case)

ACCESSORIES

The accessories that follow are approved for use with intrinsically safe radios. Use of accessories other than those listed voids Factory Mutual approval.

PAAC1J	Earpiece Kit
PAAE3E	Speaker/Microphone
PAAE 3G	Speaker/Microphone/Antenna
PANC1B	Antenna, 136 - 151 MHz, Helical
PANC1C	Antenna, 146 - 162 MHz, Helical
PANC1D	Antenna, 157 - 174 MHz, Helical

PAHC1C	Belt Clip
PAHC1D	Swivel Mount with Belt Loop
PAHC5N	Case, Leather, with Belt Loop (Short Case)
PAHC1F	Case, Leather, with Belt Loop (Tall Case)
PAHC1K	Shoulder Strap, Leather, with Mounting Plate
PAHC5R	Holster, Plastic.

MAINTENANCE

The M-PA radio is a very reliable unit and will normally provide many years of trouble-free service. The recommended Preventive Maintenance procedures that follow should be performed when a technician comes in contact with a unit. Component level troubleshooting information is contained in the Service Section.

PREVENTIVE MAINTENANCE

Antenna

The antenna and antenna contact should be kept clean and free from dirt or corrosion. If the antenna contact should become dirty or corroded, communication range could be reduced.

Battery Packs

Insure the battery packs are properly maintained. Do not over or under charge them on a regular basis. Verify the contacts are clean and free of corrosion.

Mechanical

Since portable radio units are subject to shock and vibration, check for loose plugs, knobs, screws, etc.

Transmitter Check

Check transmit frequency and deviation. Normally these checks are made when the unit is first put into operation. They should be repeated after the first month of operation, then annually.

Receiver Check

Receiver sensitivity should be checked periodically as an indication of overall receiver operation.

Cleaning

If the unit requires an external cleaning use mild soap and a damp cloth. Avoid abrasive cleaners or chemicals which may damage the plastic or rubber surfaces on the unit.

DISASSEMBLY / REASSEMBLY

In the event internal service is required, disassemble the radio in accordance with the following outlined steps. See Figures 6 - 10.

Reassemble the unit by following the steps in reverse order. Observe screw lengths and do not over tighten the screws when reassembling the unit. Torque specifications are listed in Table 3.

CAUTION

ALWAYS remove the battery pack before disassembling the unit to avoid blowing the fuse or causing other component damage.

This radio contains CMOS ICs that can be damaged by static electricity. Observe static handling precau-

Tools Required

- TORX® T6 Driver
- M1.5 Hex Driver or Wrench
- Needle-Nose Pliers
- Small Flat-Blade Screwdriver
- Spanner Wrench (top antenna jack)
- Spanner Wrench (UDC antenna jack)
- Spanner Wrench (volume control and group/channel switch)

Front and Rear Cover Separation

Lay the radio face down and loosen the four (4) Torx screws (A) on the back of the radio; complete screw removal is not necessary. See Figure 6. Separate the covers by carefully lifting the Rear Cover Assembly straight-up to avoid bending the connector pins between the RF and Control Boards.

When reassembling the unit, verify the rubber gasket surrounding the perimeter of the cover is in good condition and it is in the groove. Also verify the connector pins align properly. For proper operation, the screws should be tightened so there is no gap between the covers. It is recommended that the top screws be tightened first while squeezing the radio together to ensure the gap is completely closed. The bottom screws can then be tightened.

TABLE 3 - TORQUE SPECIFICATIONS

LOCATION	LB-IN.
Rear/Front Cover Assembly Screws	5.0
Rear Cover Assembly	
Antenna Insert	10.0
UDC RF Connector	10.0
RF Board/Eggcrate Screws	4.0
PA Support Screws	10.0
Antenna Switch (SW1) Screw	1.5
Front Cover Assembly	
Knob Set Screws (earlier)	3.0
Knob Set Screws (later)	5.0
Group/Channel and Volume Nuts	8.0
UDC Ground Screw	4.0
All M1.6 and M2 Screws	3.0

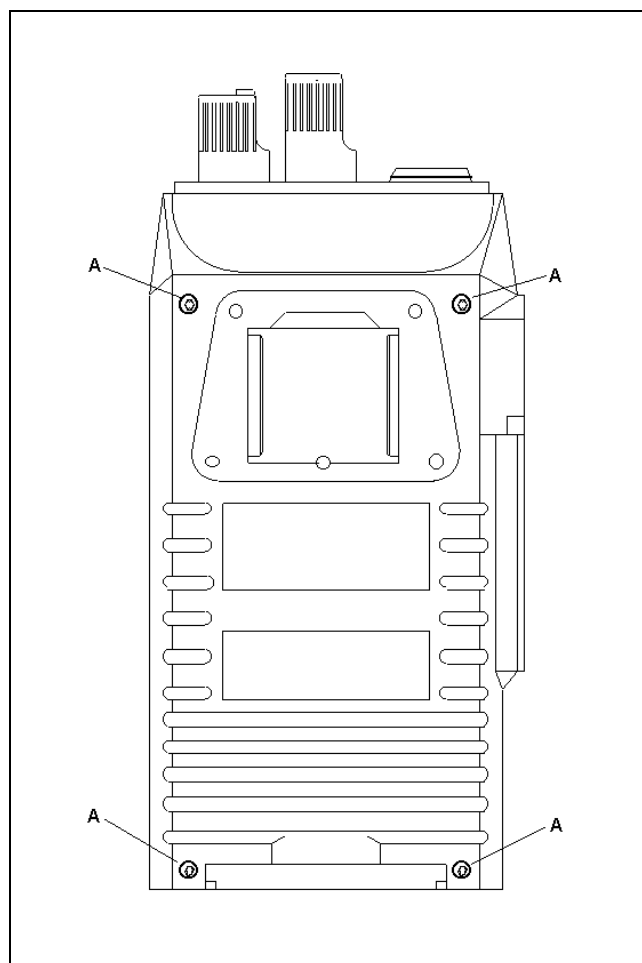

Figure 6 - Front And Rear Cover Separation

RF Board Access

Holes are located in the RF Board shield for alignment of the Reference Oscillator (**U3**), Modulation Balance pot (**R18**), VCO Modulation pot (**R19**), 2nd Local Oscillator Adjustment (**T1**), and the Quadrature Detector Adjustment (**T2**). To align these items, shield removal is not necessary.

If removal of the RF Board from the case is necessary, first remove the UDC antenna jack and the top RF antenna jack with appropriate spanner wrenches. Next, remove the five (5) Torx screws (**B**) that secure the shield then lift and remove the shield. Remove the two (2) remaining Torx screws (**C**) near the Power Amplifier Module. The RF Board and eggcrate casting can now be lifted from the Rear Cover to gain access to the chip component side of the board. If necessary, the RF Board can be separated from the eggcrate casting. Remove the two (2) Torx screws that secure the Power Amplifier Module and remove the four (4) screws on

the chip component side of the board that secure it to the casting.

Reassemble the unit in reverse order. Observe screw lengths.

Control Board Access

To gain partial access to the Control Board, remove the five (5) screws (**D**) securing the shield and board. An earlier Front Cover Assembly has an additional screw located just below connectors J4/P4 (**DD**). See Figure 8. Remove the shield.

Many of the test points on the Control Board are accessible at this point; however, the Front Cover Assembly should not be powered-up without first reinstalling the screw into the lower right-hand hole to ground the board. Also, the three (3) screws securing the top flex connectors need to be reinstalled for good flex connections. USE CAU-

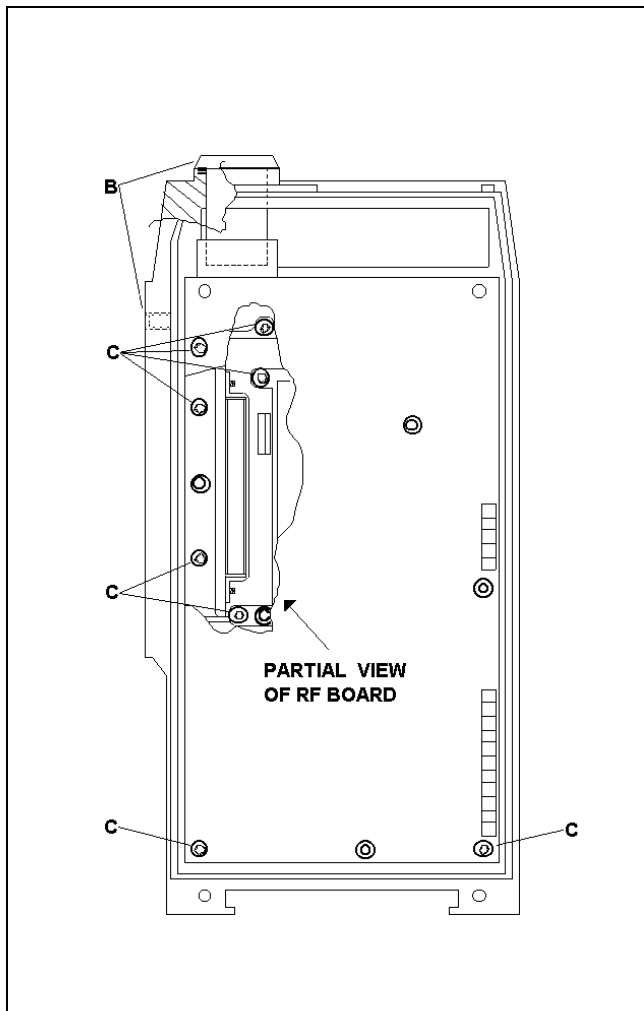

Figure 7 - RF Board Access

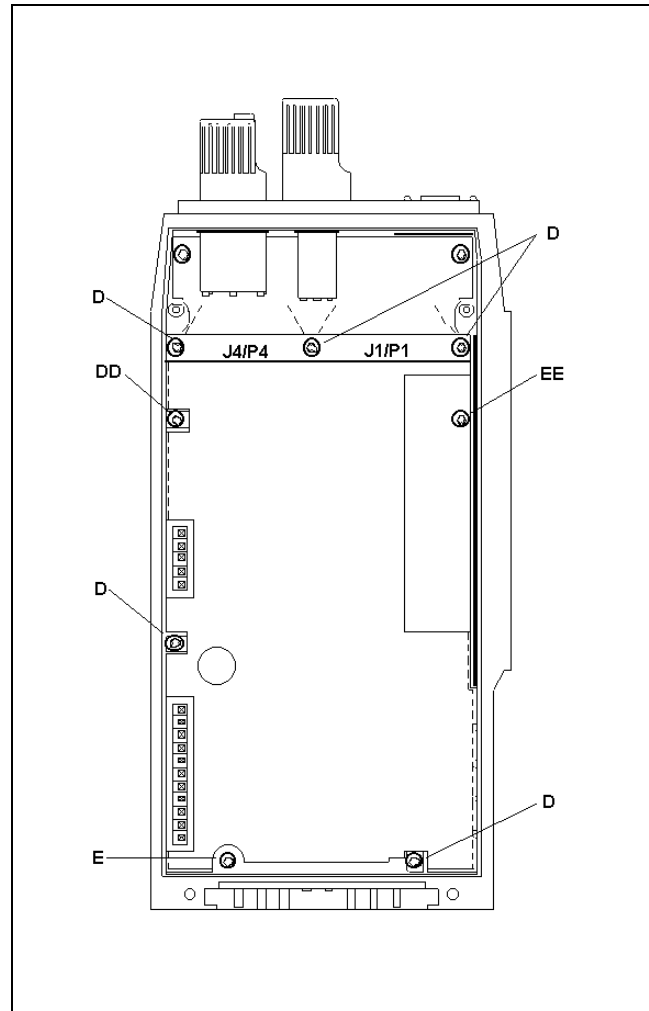

Figure 8 - Control Board Access

TION: Installation of screws that are longer than the originals may damage the LCD Board, flex circuits or the threads.

To remove the Control Board, remove the Torx screw (E) in the lower left-hand corner that supplies battery power to the board. An earlier Front Cover Assembly has an additional screw located just below connectors J1/P1 (EE). Lift the board and carefully unplug Speaker Flex plug P3 from J3 on the Control Board. Avoid bending this or any other flex circuits at sharp angles. The Control Board may now be removed. Note the battery power and ground connections at the bottom of the board where the screws have been removed.

Speaker, Microphone and Flex Circuit Access

Remove the Control Board as previously stated and then remove the six (6) Torx screws that secure the die-cast shield. Remove the die-cast shield by lifting the top end first and sliding it towards the top of the radio. The internal speaker, microphone, Keypad and UDC Flex circuits are now partially accessible. See Figure 9.

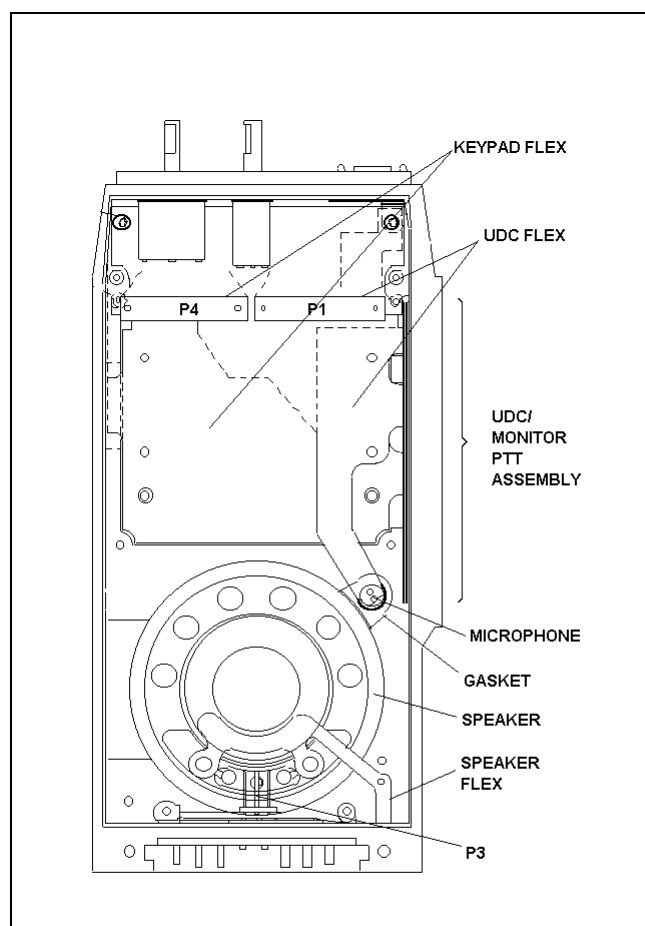

Figure 9 - Speaker, Microphone And Flex Circuit Access

UDC Flex/UDC/Monitor Button/PTT Switch Assembly Removal

If UDC Flex/UDC/Monitor Button/PTT Switch assembly removal is necessary, first un-solder the microphone. With a spanner wrench, remove the UDC securing screw (the UDC ground pin). Remove the insulator (foam or plastic) on the inside side-rail of the case. Lift the UDC/Monitor Button/PTT Switch assembly from the side of the case and slide the flex through the slot

Earlier Front Cover Assembly Keypad Flex Removal

To remove the Keypad Flex, first remove the UDC Flex/UDC/Monitor Button/PTT Switch assembly as previously stated. Next remove the knobs using the hex driver. Unscrew the two (2) screws securing the top panel and lift and remove the panel. Lift the Emergency Button Board by carefully unplugging J6 from P6. With a spanner wrench, remove the nuts securing the volume and channel controls and carefully slide the controls inside the radio. Unscrew the two (2) screws (G and GG) and remove the J10/P10 Zebra strip securing plate (HH). See Figure 10. The Keypad Flex is now free for removal.

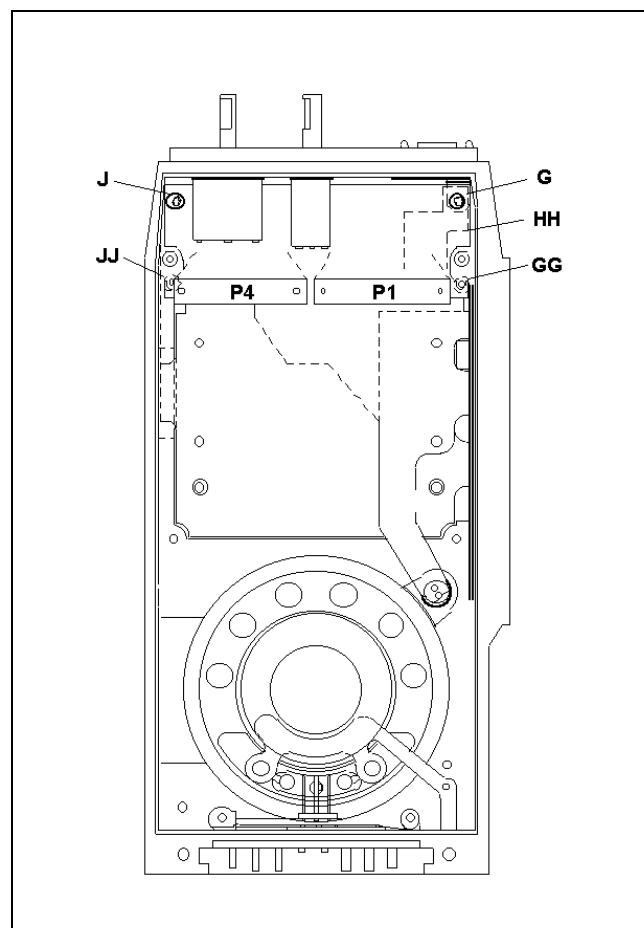

Figure 10 - Keypad Flex And LCD Board Access

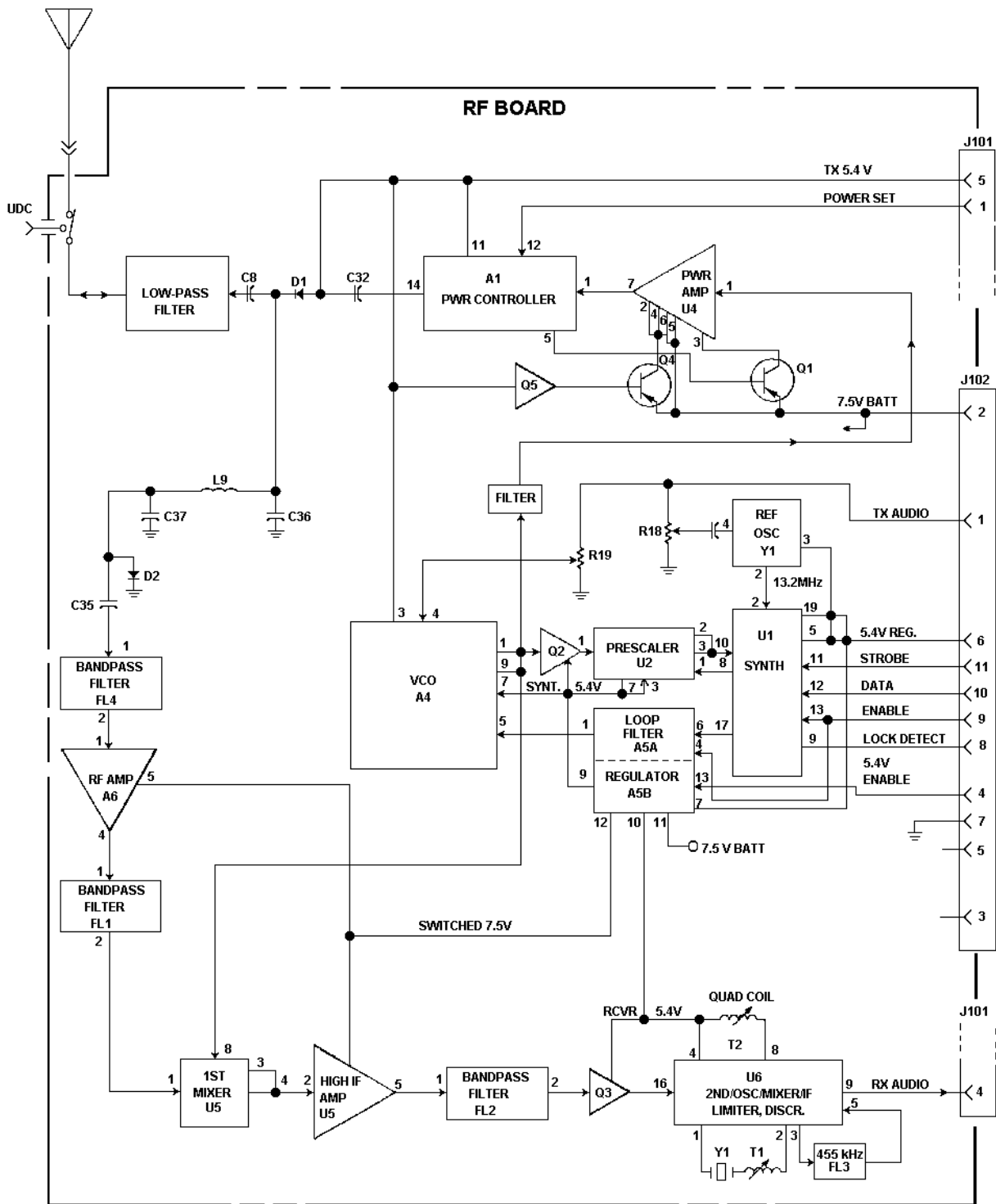

Figure 11 - Rear Cover Assembly Block Diagram

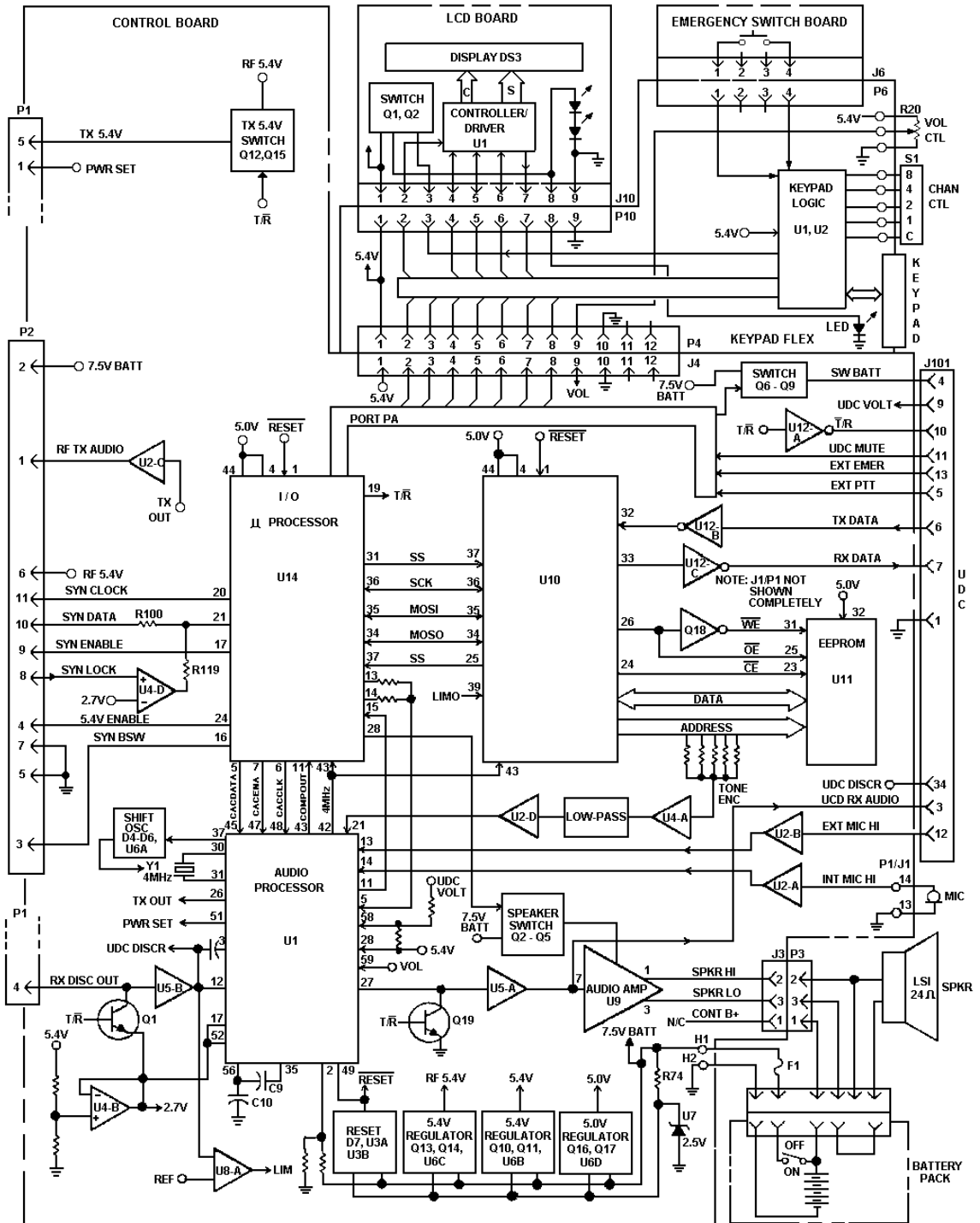

Figure 12 - Front Cover Assembly (Earlier) And Control Board Block Diagram

Later Front Cover Assembly Keypad Flex Removal

To remove the Keypad Flex, first remove the UDC Flex/UDC/Monitor Button/PTT Switch assembly as previously stated. Next remove the screw securing the emergency switch support (**G**) then remove the support. Remove the knobs using the hex driver. With a spanner wrench, remove the nuts securing the volume and channel controls and carefully slide the controls inside the radio. Unscrew the two (2) screws that secure the J10/P10 connection at the bottom of the LCD Board. Remove the screws, the plate and the rubber pad. The Keypad Flex is now free for removal.

Speaker Flex Removal

In order to replace the Speaker Flex, it must be un-soldered from the speaker and the Battery Plate.

LCD Board Access

To remove the LCD Board, partial removal (actually re-positioning of the top areas) of the Keypad Flex is required. UDC Flex/UDC/Monitor Button/PTT Switch assembly removal is not necessary.

After the top areas of the Keypad Flex have been freed as previously outlined, the LCD Board can be removed. At this point in the disassembly process an earlier Front Cover Assembly has two (2) screws on the left side as view from the back (**J** and **JJ**) and a later assembly has a single screw in the upper left-hand side (**J**). See Figure 10.