

# Software Release Notes

AE/LZT 123 4742/1 R3F

*future*  
The Future of Mobile Radio



## Orion Keypad Frequency Select Board

AE/LZY 213 881/1

**NOTICE!**

This manual covers M/A-COM products manufactured and sold by M/A-COM Private Radio Systems, Inc.

**NOTICE!**

The software contained in this device is copyrighted by M/A-COM Private Radio Systems, Inc. Unpublished rights are reserved under the copyright laws of the United States.

This manual is published by **M/A-COM Private Radio Systems, Inc.**, without any warranty. Improvements and changes to this manual necessitated by typographical errors, inaccuracies of current information, or improvements to programs and/or equipment, may be made by **M/A-COM Private Radio Systems, Inc.**, at any time and without notice. Such changes will be incorporated into new editions of this manual. No part of this manual may be reproduced or transmitted in any form or by any means, electronic or mechanical, including photocopying and recording, for any purpose, without the express written permission of **M/A-COM Private Radio Systems, Inc.**

## TABLE OF CONTENTS

	<i>Page</i>
<b>1. INTRODUCTION .....</b>	<b>4</b>
<b>2. COMPATIBILITY .....</b>	<b>4</b>
<b>3. NEW FEATURES/ENHANCEMENTS.....</b>	<b>4</b>
<b>4. PROBLEM RESOLUTIONS .....</b>	<b>4</b>
<b>5. INSTALLATION PROCEDURES.....</b>	<b>5</b>
5.1 188D5771 ORION DESKTOP MICRO BOARD FLASH PROCEDURE.....	5
<b>6. DOCUMENTATION UPDATES .....</b>	<b>9</b>

# 1. INTRODUCTION

This document contains Software Release Notes for Orion Keypad Frequency Select Board Software, product number LZY 213 881/1, R-state R3E.

# 2. COMPATIBILITY

This software is compatible with the Orion Keypad Frequency Select Board, product number 188D5771

# 3. NEW FEATURES/ENHANCEMENTS

There are no new features or enhancements with this release.

# 4. PROBLEM RESOLUTIONS

Reference No.	Problem Description
6111	I-calls from desk mic time out after three seconds
6128	Remote PTT delayed 1-2 seconds

## 5. INSTALLATION PROCEDURES

This software is programmed into the Orion Keypad Frequency Select Board per the instructions below.

### 5.1 188D5771 ORION DESKTOP MICRO BOARD FLASH PROCEDURE

The 188D5771 Micro Board is meant to be flashed from a fixture similar to a 188D5418 Desktop Station Interconnect board connected by a cable to an IBM-compatible computer through a TQ3370 box (see Figure 1). To flash a board, verify that the power to the fixture is off. Insert the board, taking care to note its orientation. If the fixture is a 5418 interconnect board, the TO220 regulator on the 5771 board should be next to the terminal block (J200) connector on the 5418 board.

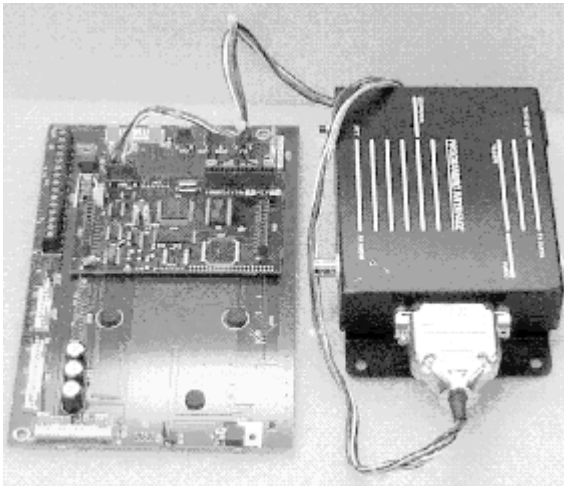
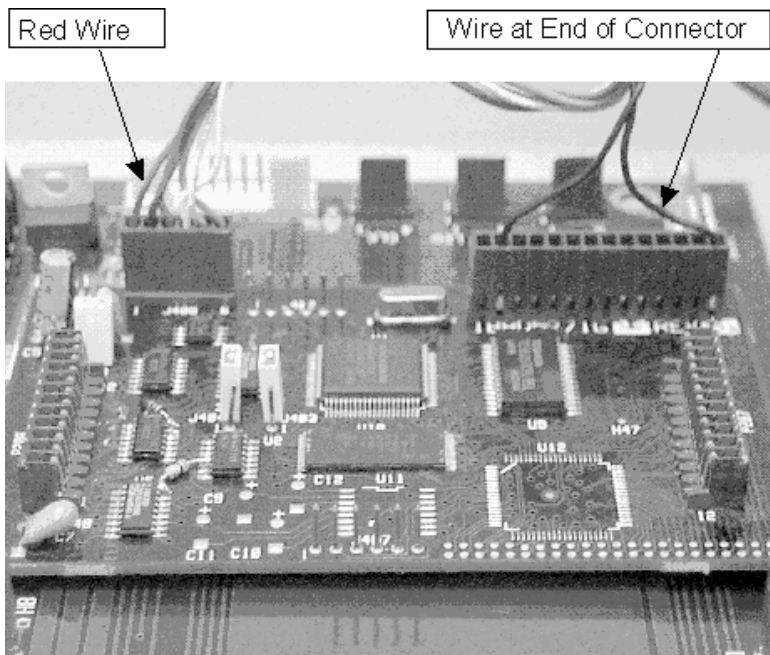

**Figure 1. Interconnect Board Connected to TQ3370 Box**

Verify that all three jumper plugs are on the micro board. J403 and J404 connect pins two and three. They select the RS485 drivers rather than the open collector transistor interface. J406 connects pins one and two. It is a pullup on service request.

Connect the DB25 end of the flashing cable to the radio end of the TQ3370 box. Connect the cable's six pin connector (P208) to the 5771 board's J408. Connect the cable's fourteen pin connector (P401) to the

5771 board's J401. Note the orientation of the connectors (refer to Figures 2 and 3). The red wire in the cable should be closest to the TO220 regulator. P408 supplies the data, flash voltage supply, an external reset, and a line that disables the 5771 board's 485 receive driver. The 485 driver must be disabled or else it will conflict with the computer's RX data path into the RCP.



**Figure 2. Cable Installation**

P401 grounds pin 13 which, at reset, tells the RCP to enter its program mode. Its program mode is also our flashing mode. The orientation of this connector should be as follows: the end with the cable at the edge of the connector should be placed in the corner of the board.

Power up the fixture. Wait a couple of seconds for things to come up to speed. Then press the PTT switch on the TQ3370 box. This sets the radio into flashing mode. Generally speaking, a board must be reset an even number of times to get into flashing mode. One should make many attempts to get the board's attention before concluding that there are hardware problems on the board.



It is often useful to monitor the A0 address line with a scope. When the RCP is hung, it is either constantly toggling A0 or there is no activity on A0. When in program mode, there will be a distinctive pattern of 250  $\mu$ Sec burst of activity every 2.5 mSecs.

Flash the board by running the current version of the MRK/Orion product's PCCOM PC program. The command line should read:

```
pccomm /c ? /wc currentrev.bin
```

where "?" is the com port that the TQ3370 box is connected to and "currentrev.bin" is the filename of the current revision of software. Consult the 188D5771 part list to obtain the group number of the current revision of software. On some computers, it is useful to force a baud rate selection. This can be done by adding a "/b ????" parameter to the PCCOMM command line, where "????" is the desired baud rate. It is usually convenient to put this command line in a simple bat file. This is done in file T.bat.

PCCOMM will download a ram loader to the micro board if the baud rate is greater than 9600. After that, it will erase and flash the board. There will be a running percentage of completion number as the board is flashed. It is normal for this number to stop updating for suspiciously long periods of time. The program is somewhat dependent on PC processor speed. The computer should be a 386 or better. Flashing can take several minutes.

Running this program out of a Windows® DOS box has produced some interesting results. Sometimes, Windows is less than willing to lend out a com port. The problem seems particularly common when the last Windows program to use the port sets it at other than one of the three baud rates used by PCCOMM. Should the program get the board's attention, it will often display a "Connected At Baud Rate -1" message.

After PCCOMM completes, remove power from the board by turning off the power supply. Remove the flash cable from the board. The unit should then power up in its flash software. Generally speaking, it is a good idea to power cycle at the power supply so that an attached radio is reset as well. Do not be too quick to turn the power back on. There is enough capacitance in the supply to hold the desktop up for several seconds after the switch is turned "off".



## **6. DOCUMENTATION UPDATES**

There are no documentation updates with this release.

## NOTES

## NOTES

**M/A-COM Wireless Systems**

3315 Old Forest Road

Lynchburg, Virginia 24501

(Outside USA, 434-385-2400) Toll Free 800-528-7711

[www.macom-wireless.com](http://www.macom-wireless.com)

Printed in U.S.A.